

SUBMITTAL DATA SHEET



Series Name: Multi Zone Hyper Heat Series
Model Number: M05HX-H36B-2A

Multi Zone Heat Pump System

Location:	Approval:
Engineer:	Date:
Submitted to:	Construction:
Submitted by:	Unit #:
Reference:	Drawing #:



OUTDOOR SPECIFICATION

Compressor Type		TWIN-ROTARY
Compressor Model		EKPQ420D1UMUA
Refrigerant		R454B
Refrigerant Oil Charge(mL)		1460
Refrigerant Oil		VG75
Outdoor Air Flow (Max) (CFM)		3037
Outdoor Noise Level (dBA)		65
Dimension (W×D×H)	inch	38.58 x 16.34 x 38.39
	mm	980×415×975
Package (W×D×H)	inch	45.08 x 19.68 x 42.52
	mm	1145×500×1080
Net/Gross Weight	lbs	211.86/244.71
	kg	96.1/111

ELECTRICAL

Power Supply	208/230V,60Hz,1Ph
System MCA	37
Connection Wiring	AWG 14-4
System MOCP	40
Compressor RLA	20.5
Outdoor Fan Motor RLA	2.6
Outdoor Fan Motor W	250
Indoor Fan Motor RLA	/
Indoor Fan Motor W	/
System Power Input @ Cooling (W)	2750/(600 ~ 4000)
System Power Input @ Heating (W)	2638/(600 ~3750)
MCA: Min. circuit amps (A)	MOCP: Max. over current protection (A)
RLA: Rated load amps (A)	W: Fan motor rated output (W)

EFFICIENCY

Cooling		Heating	
SEER2	23.0	HSPF2-4	10.7
EER2	13	COP	4.0

PERFORMANCE of Cooling

Cooling (Btu/hr)	
Rated Capacity	36000
Min/Max Capacity	9000~43000
Moisture Removal(L/h)	2
Standard Operating Range(°F/°C)	-22~122/(-30 ~ 50)
Rated Cooling Conditions:	Indoor: 80°F DB/67°F WB Outdoor: 95°F DB/75°F WB

PERFORMANCE of Heating

Heating (Btu/hr)	
1. @ 47°F Rated	36000
1. @ 47°F Min/Max Capacity	10000~44000
2. @ 17°F Rated(H32)	30000
3. @ 5°F Rated: Capacity / COP(H4)	36000/2

PIPING

Liquid Size	5x6.35mm(5x1/4in)
Gas Size	3x9.52mm+2x12.7mm(3x3/8in+2x1/2in)
Max. Piping Length for all	262.4/(80)
Max. Piping Length for one	114.8/(35)
Height Difference of IDU and ODU(ft)	49.2/(15)
Refrigerant Pre-charged	134.04/(3.8)
Refrigerant Precharge Length(ft/m)	24.6(7.5)x5
Additional Charge of Refrigerant (Φ6.35 (1/4") liquid pipe)	0.16/(15)
Additional Charge of Refrigerant (Φ9.52 (3/8") liquid pipe)	0.32(30)
Connection Method	Flared

3. @ 5°F Max: Capacity	36000
Standard Operating Range(°F/°C)	-22~75/(-30 ~ 24)
1. Conditions:	Indoor: 70°F DB/60°F WB Outdoor: 47°F DB/43°F WB
2. Conditions:	Indoor: 70°F DB/60°F WB Outdoor: 17°F DB/15°F WB
3. Conditions	Indoor: 70°F DB/60°F WB Outdoor: 5°F DB/5°F WB

Outdoor Unit Dimension

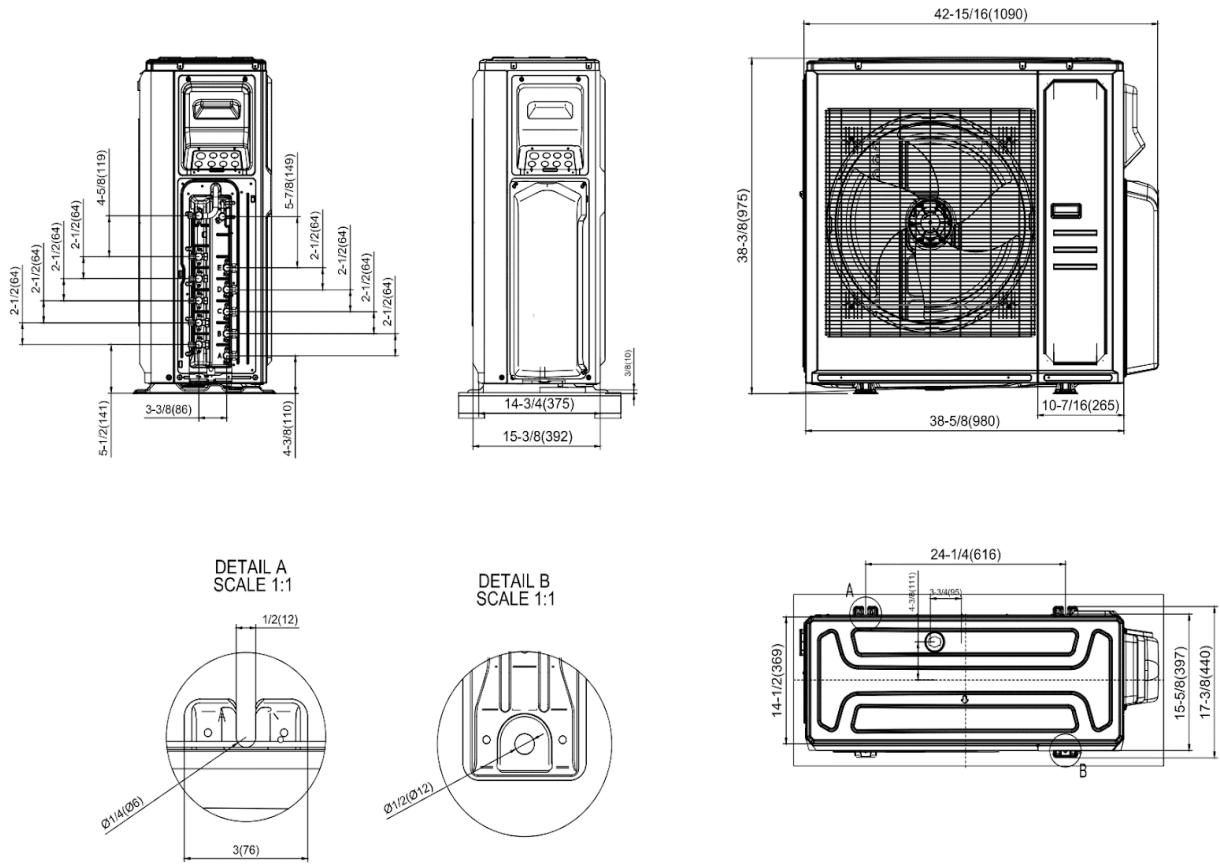

Installation Instruction

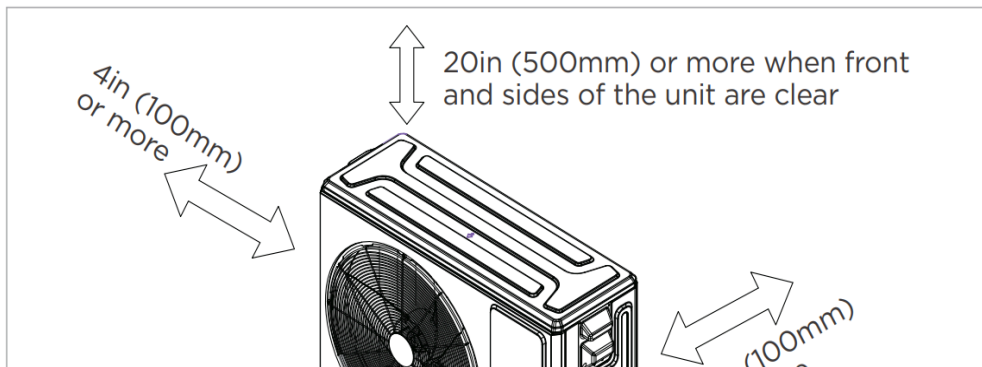

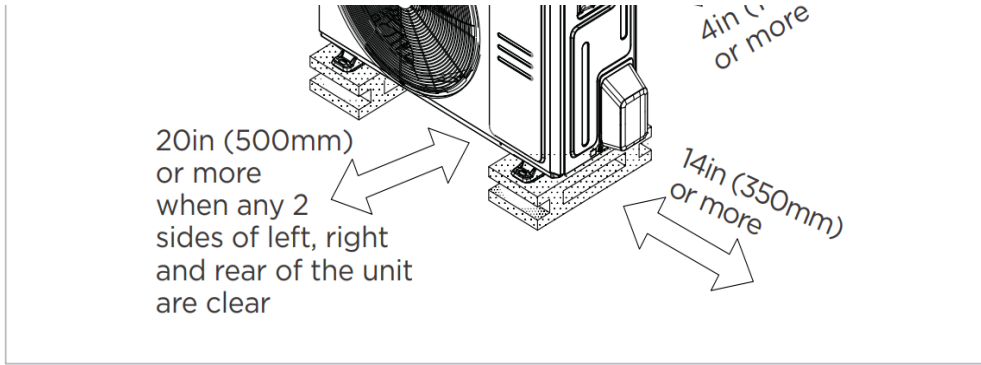

- Meets all spatial requirements shown in Installation Clearance Requirements above.