

NAHVAC

North American HVAC

2025

ALL-IN-ONE HVAC SOLUTIONS

- READY STOCK
- COMPETITIVE PRICING
- PREMIUM QUALITY

HVAC ACCESSORIES CATALOG



**Single Insulated
Copper Pipe**



**Insulated Copper
Line Sets**



ACR Pancake Coil



Drain Hose



Line Set Cover Kit



Mute Box Pump



Tank Pump



Mute Wedge Pump



Rubber Support



**Outdoor Wall
Mounting Bracket**



**Equipment Stand
Heavy Duty**

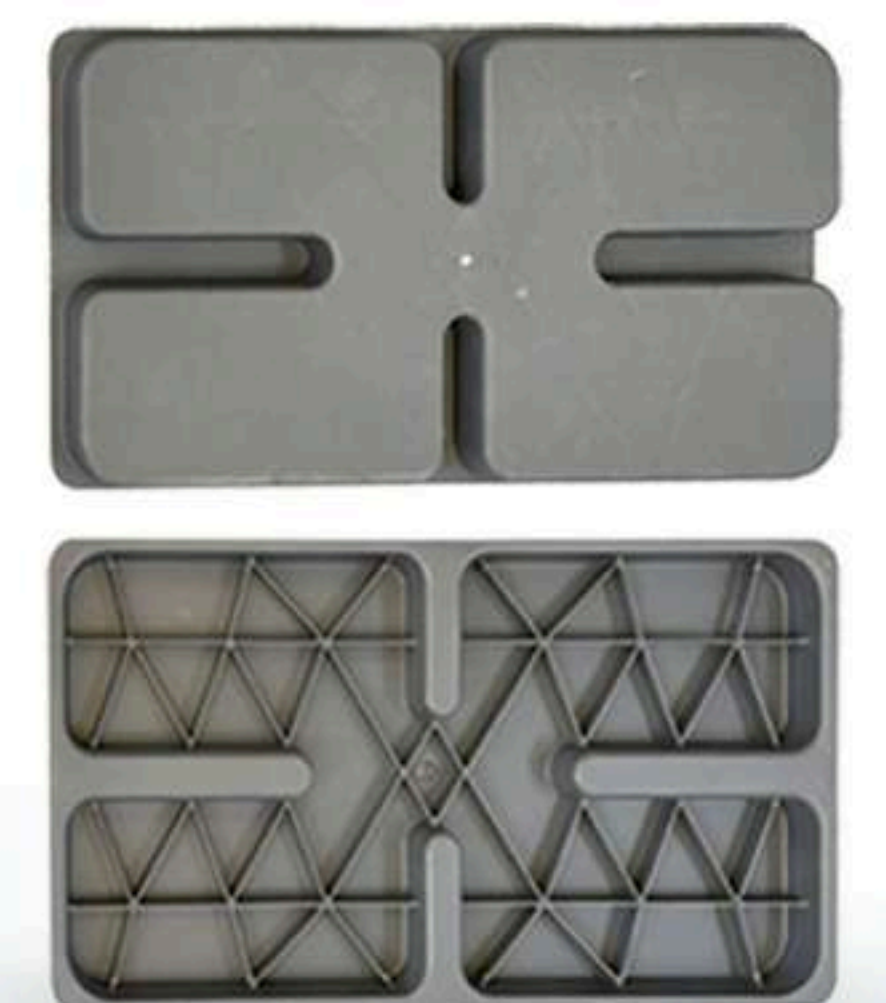

Heat Pump Stand



Wire Cable



Disconnect Box



AC Whip



M-Station



Control Box 24V

NAHVAC reserves the right to change the specifications of the product, and to withdraw or replace products without prior notification or public announcement. NAHVAC is constantly developing and improving its products.

Floor Support – RBS Rubber Support



- Heavy-duty adjustable ground mounting set
- Install directly onto concrete or leave unmounted
- Adjustable wide frame fits most if not all ductless units
- Black SBR recycled rubber frame provides excellent vibration absorption and durability
- Elevates ductless units while maintaining a low profile
- Includes built-in leveler tool to assist with mounting
- Easy installation

Code	RBS-10	RBS-16	RBS-24	RBS-39
Product Description	Rubber Support	Rubber Support	Rubber Support	Rubber Support
Size	250mm (10 in)	400mm (16 in)	600mm (24 in)	1000mm (39 in)
Dimensions	250x160x90mm(10x7x4 in)	400x160x90mm (16x7x4 in)	600x160x90mm (24x7x4 in)	1000x160x90mm (40x7x4 in)
Weight	5 kg (11 lbs)	7.80 kg (17.2 lbs)	12.50 kg (27.6 lbs)	20 kg (44 lbs)

Installed on site



Category:
Miscellaneous

NAHVAC reserves the right to change the specifications of the product, and to withdraw or replace products without prior notification or public announcement. NAHVAC is constantly developing and improving its products.

Single Insulated Copper Pipe with 3/8" Black Polyethylene Insulation



- Universal black PE single insulated copper line
- PE insulation thickness: 3/8 inch
- Copper tube: ASTM B280
- Surface burning characteristics: UL 94
- Meets ASTM E84 for smoke and fire
- External surface resistant to UV
- Line sets are available in 50ft & 164ft length

50ft length

TCP1/4L50	50 ft ACR line – 1/4" single copper pipe
TCP3/8L50	50 ft ACR line – 3/8" single copper pipe
TCP1/2L50	50 ft ACR line – 1/2" single copper pipe
TCP5/8L50	50 ft ACR line – 5/8" single copper pipe
TCP3/4L50	50 ft ACR line – 3/4" single copper pipe
TCP7/8L50	50 ft ACR line – 7/8" single copper pipe



164ft length

TCP1/4L164	164 ft ACR line – 1/4" single copper pipe
TCP3/8L164	164 ft ACR line – 3/8" single copper pipe
TCP1/2L164	164 ft ACR line – 1/2" single copper pipe
TCP5/8L164	164 ft ACR line – 5/8" single copper pipe

Insulated Copper Line Sets



- All Line sets include copper lines with both liquid and suction lines insulated with rubber.
- Each set is equipped with flare nuts on both ends.
- They are convenient and inexpensive and they contain everything you need for quick and easy installation.
- Line sets are available in 15ft, 25ft, and 50ft lengths.

Model No.

Description

TCP09L15	15 feet line set – 1/4" liquid & 3/8" suction line with 1/2" insulation
TCP09L25	25 feet line set – 1/4" liquid & 3/8" suction line with 1/2" insulation
TCP09L50	50 feet line set – 1/4" liquid & 3/8" suction line with 1/2" insulation
TCP12/18L15	15 feet line set – 1/4" liquid & 1/2" suction line with 1/2" insulation
TCP12/18L25	25 feet line set – 1/4" liquid & 1/2" suction line with 1/2" insulation
TCP12/18L50	50 feet line set – 1/4" liquid & 1/2" suction line with 1/2" insulation
TCP24L15	15 feet line set – 3/8" liquid & 5/8" suction line with 1/2" insulation
TCP24L25	25 feet line set – 3/8" liquid & 5/8" suction line with 1/2" insulation
TCP24L50	50 feet line set – 3/8" liquid & 5/8" suction line with 1/2" insulation



Category: Insulated Line Sets

NAHVAC reserves the right to change the specifications of the product, and to withdraw or replace products without prior notification or public announcement. NAHVAC is constantly developing and improving its products.

NAHVAC ACCESSORIES

NAHVAC
North American HVAC

Outdoor Wall Mounting Bracket (For 9,000-36,000 BTU)



- Adjustable to fit 9,000 BTU – 36,000 BTU units with a maximum weight capacity of 300 lbs.
- Powder-coated hardened steel. Hardware included for attaching the condenser and expansion bolts to the wall mounting.
- Built-in vibration control and shock absorbers. Adjustable backstop.
- Ideal solution for mounting mini split condensers above ground on multi-level buildings
- Provides more protection from ground-level debris, heavy rains, floods, vandalism, etc. than ground pads

SKU: OWMB09-30K **Category:** Miscellaneous

Equipment Stand – Heavy Duty

This ground stand is designed to work with most mini split air conditioner systems, it can support over 330lbs of weight and can easily be placed outside your home or business.

- A perfect addition to any ductless split air conditioner purchase.
- Supports up to 250kg (550 lbs).
- Weatherproof design for long-lasting support.

Category: Miscellaneous

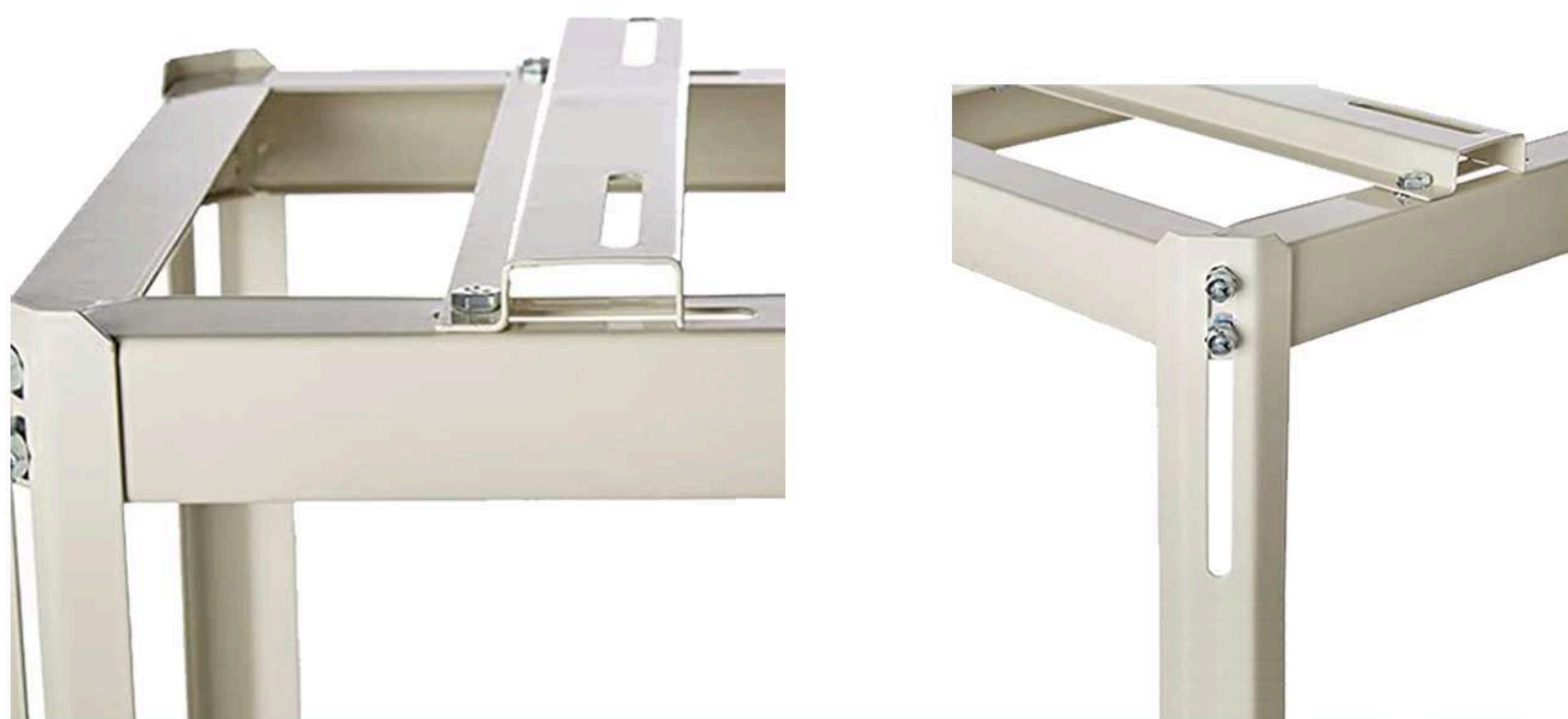

SKU: GB09-18K
(For 9,000-18,000 BTU)

(L x W x H)
85cm x 38cm x 40cm

SKU: GB24-36K
(For 24,000-36,000 BTU)

85cm x 48cm x 40cm

SKU: GB36-60K
(For 36,000-60,000 BTU)

100cm x 55cm x 40cm

NAHVAC reserves the right to change the specifications of the product, and to withdraw or replace products without prior notification or public announcement. NAHVAC is constantly developing and improving its products.

NAHVAC ACCESSORIES

NAHVAC
North American HVAC

Drain Hose 50 Meter/ 164 Inch, 5/8" Inside Diameter



- Model Number: DH-50M
- 164 Ft Drain Hose for Ductless Mini Split Air Conditioner Heat Pump Systems 5/8 ID
- Contractors Grade, Non-Insulated
- Design to Fit All Ductless Mini Split Air Conditioner and Heat Pump Systems specifying 5/8 ID Drain Line
- It Can Be Cut for An Exact Installation

Category: Miscellaneous

Heat Pump Stand – Max Load 600 lbs

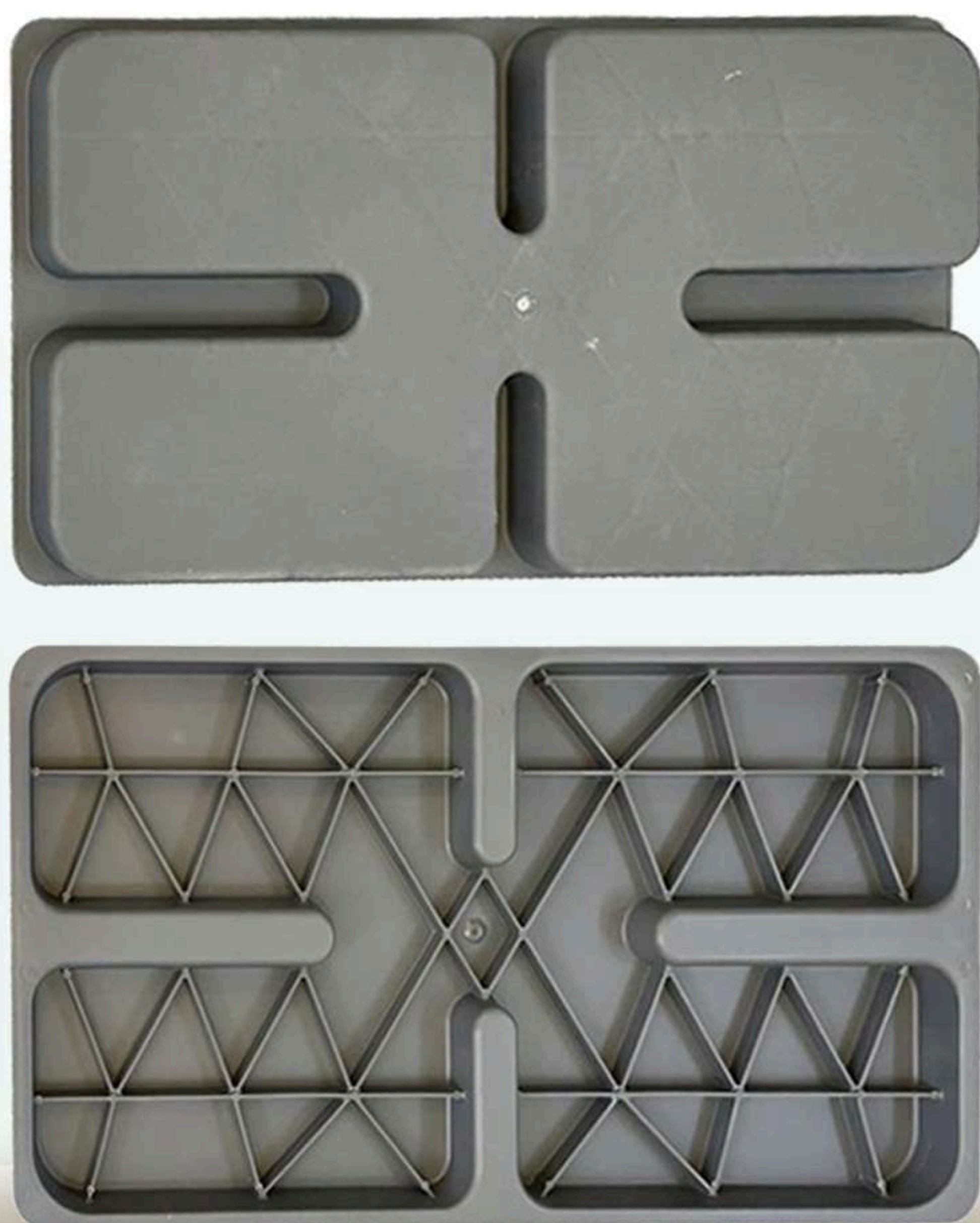

- Model Number: HPB-35
- Dimension: 35x18x2" (880x460x50mm)
- Contractors Grade, Heavy Duty and Weather Proof
- Design to Fit All Ductless Mini Split Air Conditioner and Heat Pump Outdoor Unit

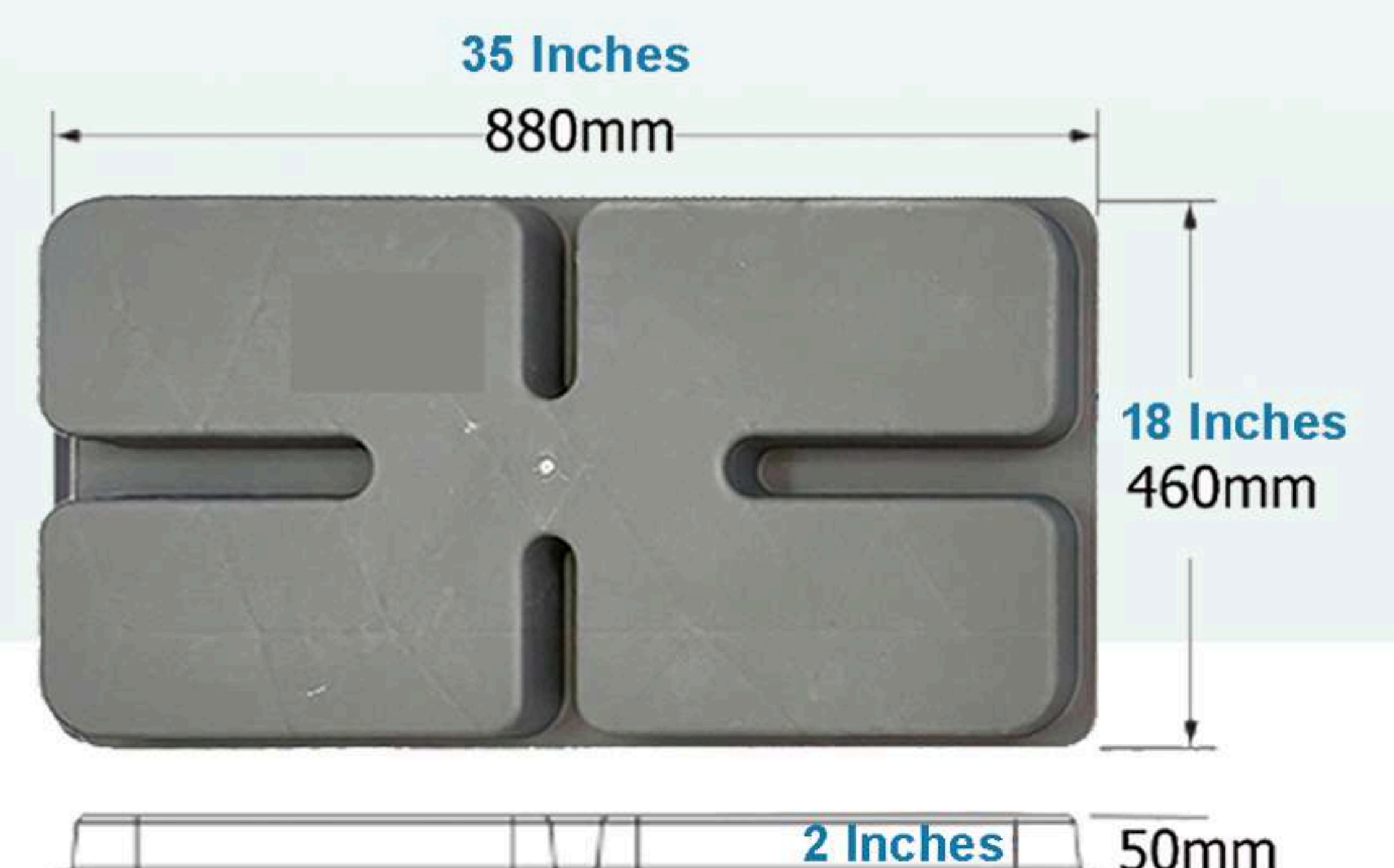

Category: Miscellaneous

NAHVAC reserves the right to change the specifications of the product, and to withdraw or replace products without prior notification or public announcement. NAHVAC is constantly developing and improving its products.

NAHVAC ACCESSORIES

NAHVAC
North American HVAC

ACR Pancake Coil – ASTM B280



- Seamless copper tube for air conditioning refrigeration meet or exceeding quality standards
- ACR Coil is minimum of 99.9% pure copper tube (Alloy 12200)
- Tube supplied meets ASTM B280

1/4L50	50 ft 1/4" single copper pipe
--------	-------------------------------

3/8L50	50 ft 3/8" single copper pipe
--------	-------------------------------

1/2L50	50 ft 1/2" single copper pipe
--------	-------------------------------

5/8L50	50 ft 5/8" single copper pipe
--------	-------------------------------

3/4L50	50 ft 3/4" single copper pipe
--------	-------------------------------

7/8L50	50 ft 7/8" single copper pipe
--------	-------------------------------

Category: ACR Pancake Copper Pipe

Control Box – 24V Interface Kit 230V

- **Gen 2 Interface Module:** Enables control of ductless systems with standard 24V thermostats (single/multi-zone). Can prevent electric/auxiliary heat during cooling—ideal for condos needing system integration.

- **Gen 3 Interface Module:** Works with multi-zone systems using third-party air handlers or A-coils alongside ductless units. Compatible with all North American 24V thermostats.

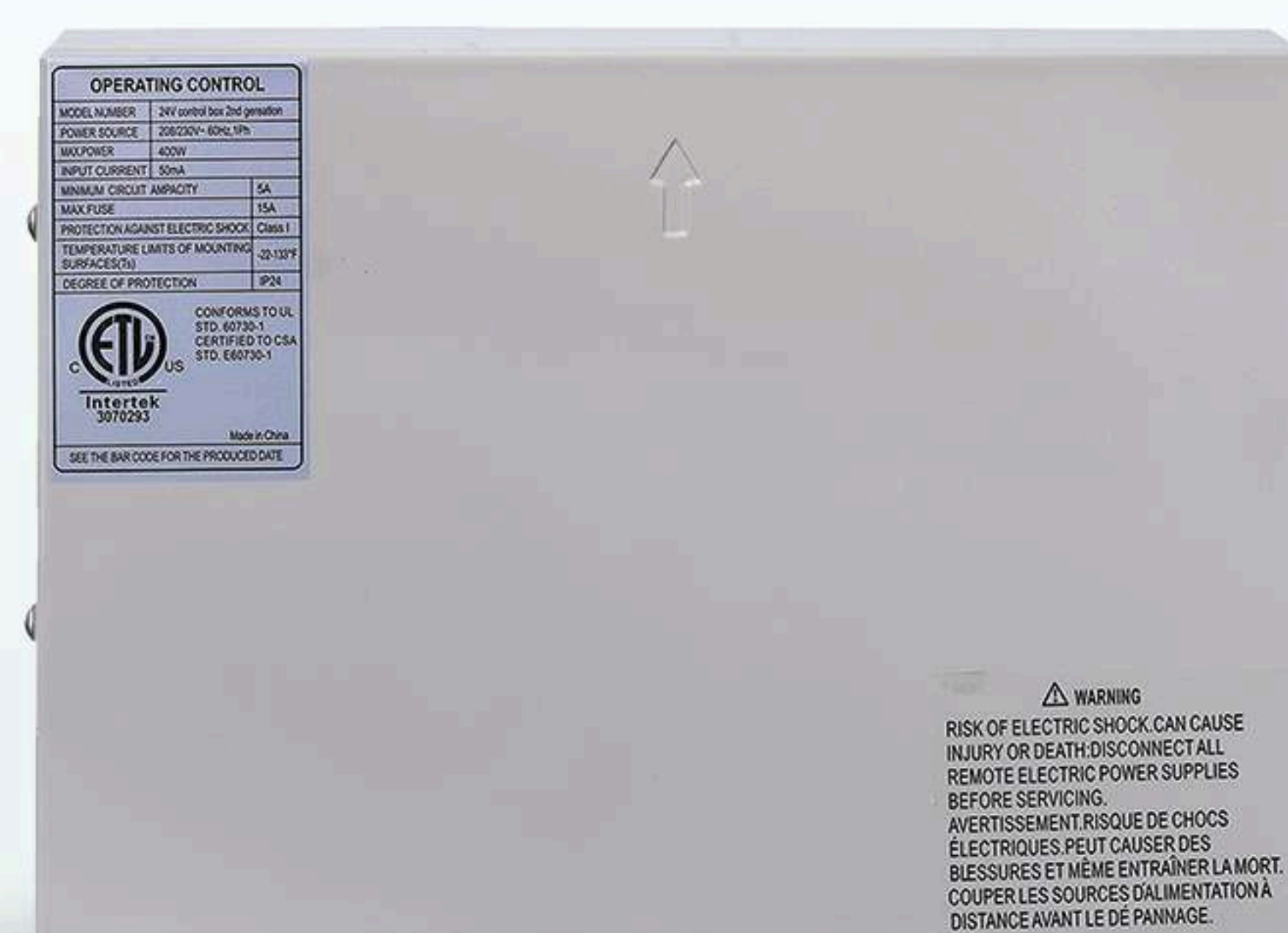

SKU: 24V interface module

Category: Miscellaneous

NAHVAC reserves the right to change the specifications of the product, and to withdraw or replace products without prior notification or public announcement. NAHVAC is constantly developing and improving its products.

Condensate Pump

NAHVAC

North American HVAC

Tank Pump CP-24TL115/CP-24TL230



Application

Excess condensate removal for Eco-Air HVAC

Purpose

This product is designed to remove condensate or excess water from Eco-Air HVAC equipment automatically.

Advantages

The Eco-Air Tank Pump product is a tested, quality ensured product that runs for far longer than most pumps on the market. These Eco-Air Tank Pumps are also made from the highest quality workmanship and material, engineered to be a reliable product. Additionally, the pumps are compatible and designed to work proficiently and safely with all Eco-Air Products.

Max Condensate Temperature:	70° C	Rated Voltage:	115V/230V AC
Water Flowrate at 1.5m(L/H):	480/520	Frequency	50/60
Max Flowrate	40L/H	Tank Capacity	260 ml
Discharge Head:	24'/7.3M	Rated:	Continuous
Water Storage	230 ML	Power	125/110
Current	0.45 - 2.2 I	CE and ETL :	II Appliance
Safety Switch:	3A Normally Closed	Sound Level	<19 db(A) @ 1 m

TYPICAL PERFORMANCE

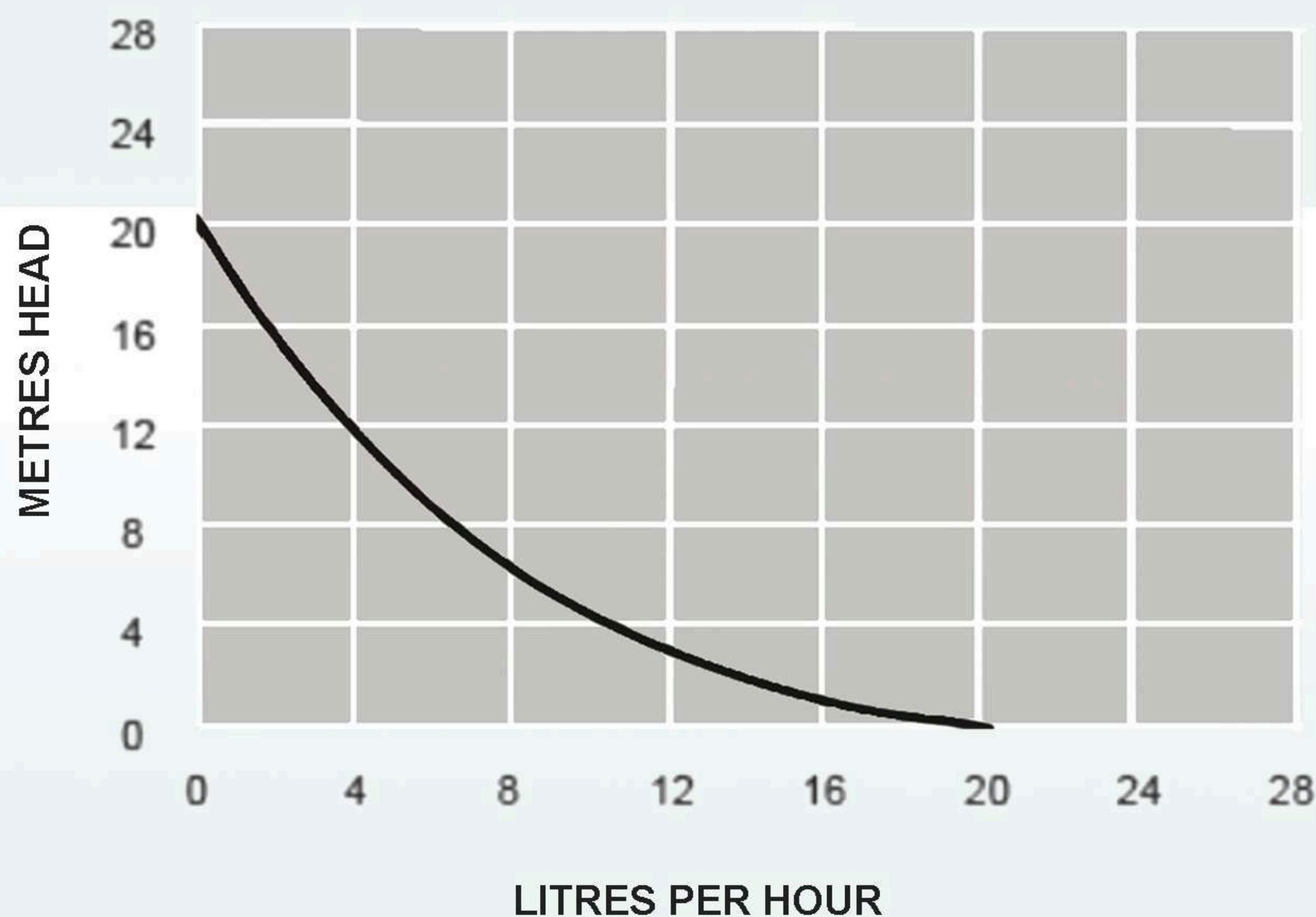

NAHVAC reserves the right to change the specifications of the product, and to withdraw or replace products without prior notification or public announcement. NAHVAC is constantly developing and improving its products.

Condensate Pump

NAHVAC

North American HVAC

Mute Box Pump (CP-MB40)



Application

Excess condensate removal for Eco-Air HVAC

Purpose

This product is designed to remove condensate or excess water from Eco-Air HVAC equipment automatically.

Advantages

The Eco-Air Tank Pump product is a tested, quality ensured product that runs for far longer than most pumps on the market. These Eco-Air Tank Pumps are also made from the highest quality workmanship and material, engineered to be a reliable product. Additionally, the pumps are compatible and designed to work proficiently and safely with all eco air wall mount heating units.

- Power supply : 100-240V AC
50/60Hz < 4W
- Max.flow: 38L/h @ 0 head
- Sound level: <19dB(A) @ 1m
- Max.recommended head: 20m
- Max.suction lift: 2m
- Max.unit output: 28kw / 95550 Btu/h
- Safety switch: 3A Normally closed
- Max.water temperature: 70°C
- Discharge tube: 6mmID
- Class: II appliance
- Rated: continuous
- IP Protection: IPX5
- Thermal protection: ✓
- Fully potted: ✓
- CE marked
- LxWxH:185mmx36mmx34mm

TYPICAL PERFORMANCE

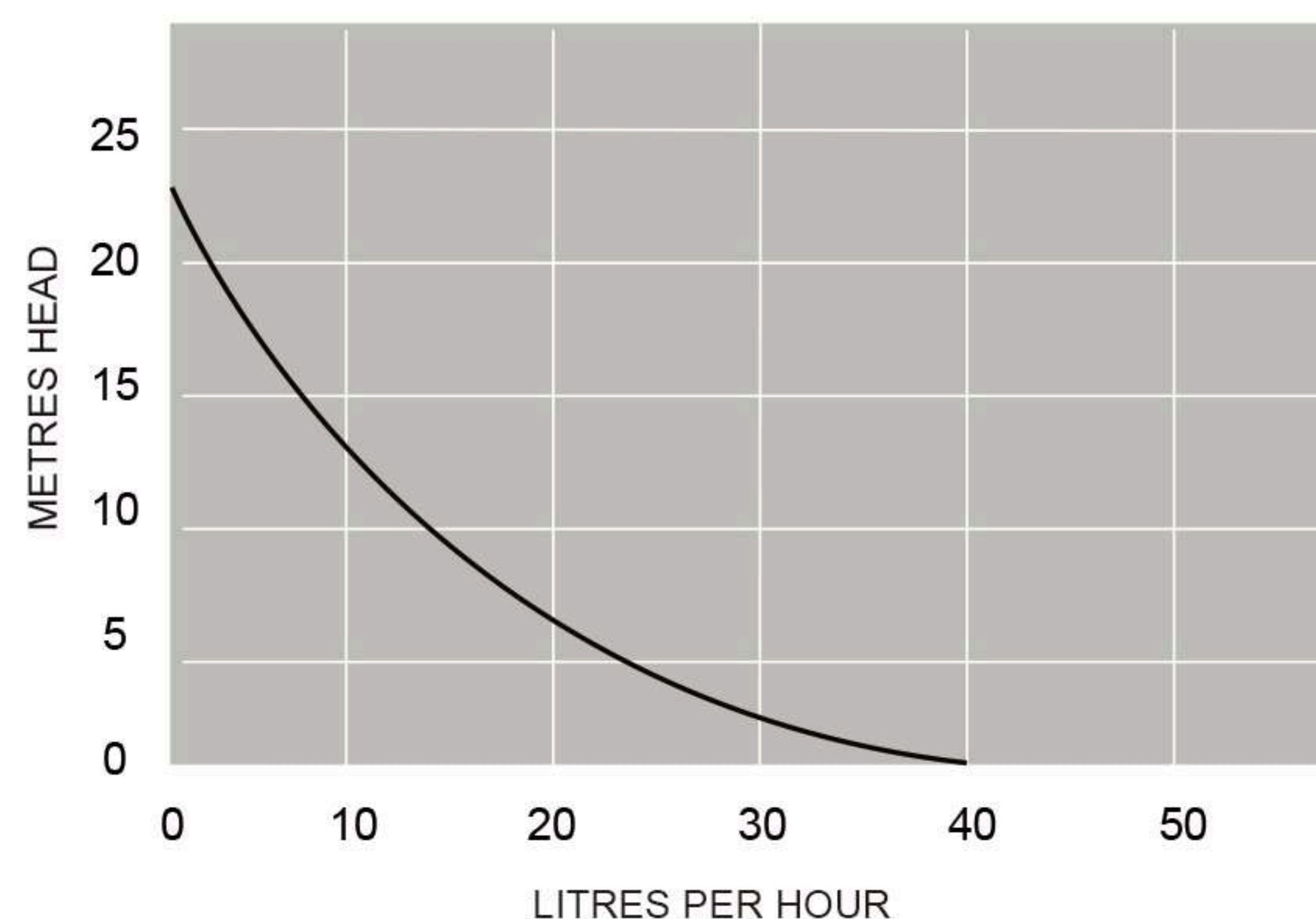

Mute Wedge Pump CP-MW40



Application

Excess condensate removal for Eco-Air HVAC

Purpose

This product is designed to remove condensate or excess water from Eco-Air HVAC equipment automatically.

Advantages

The Eco-Air Tank Pump product is a tested, quality ensured product that runs for far longer than most pumps on the market. These Eco-Air Tank Pumps are also made from the highest quality workmanship and material, engineered to be a reliable product. Additionally, the pumps are compatible and designed to work proficiently and safely with all Eco-Air Products.

- Power supply : 100-240V AC
50/60Hz
- Max.flow: 38L/h @ 0 head
- Sound level: <19dB(A) @ 1m
- Water storage: 230ml
- Max.recommended head: 20m
- Max.unit output: 28kw / 95550 Btu/h
- Safety switch: 3A Normally closed
- Max.water temperature: 70°C
- Discharge tube: 6mmID
- Class: II appliance
- Rated: continuous
- IP Protection: IPX5
- Fully potted: ✓
- LxWxH: 164mmx70mmx102mm
- CE marked

TYPICAL PERFORMANCE

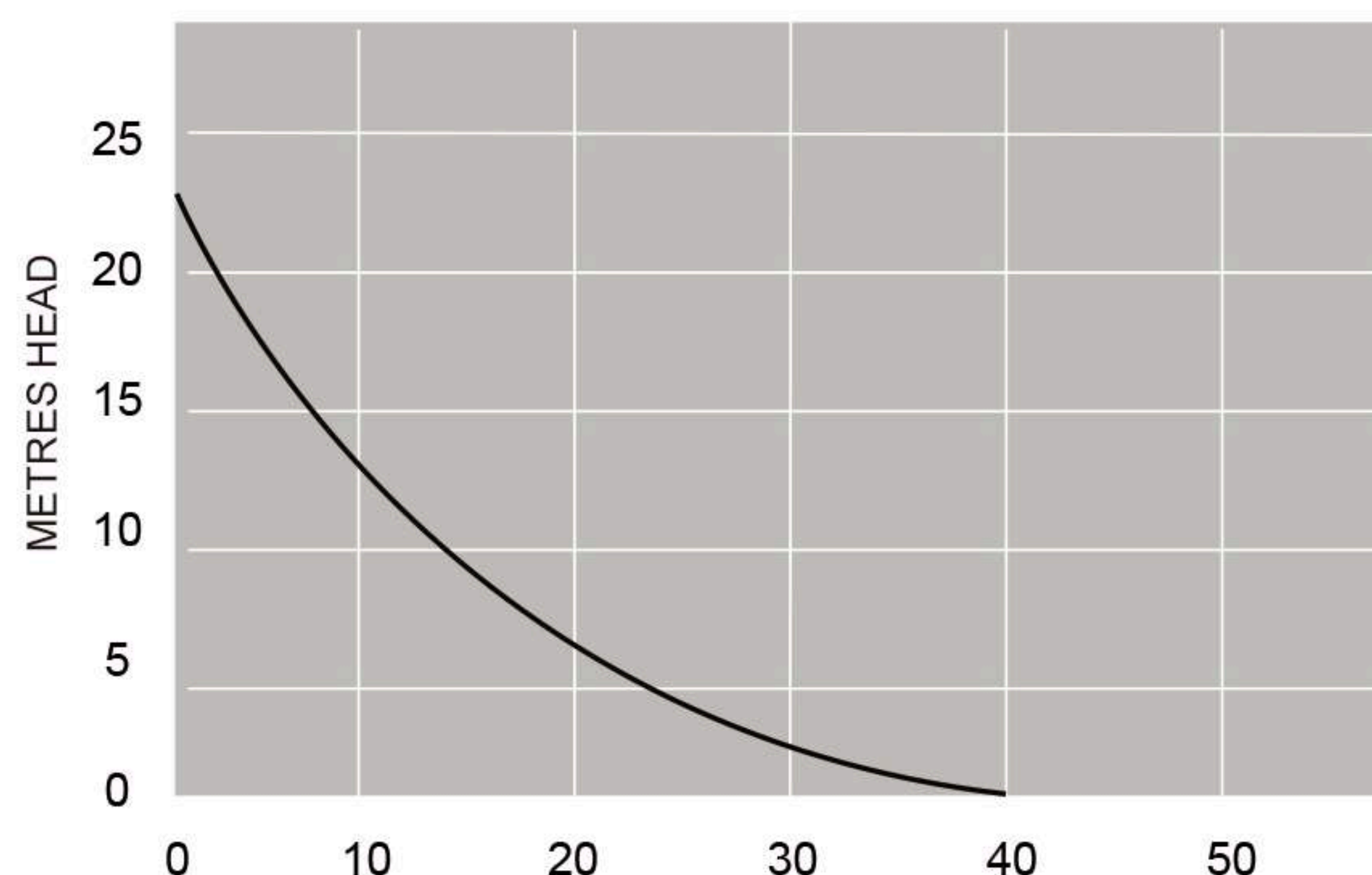

NAHVAC reserves the right to change the specifications of the product, and to withdraw or replace products without prior notification or public announcement. NAHVAC is constantly developing and improving its products.

Line Set Cover Kit

14 Ft Decorative

NAHVAC
North American HVAC

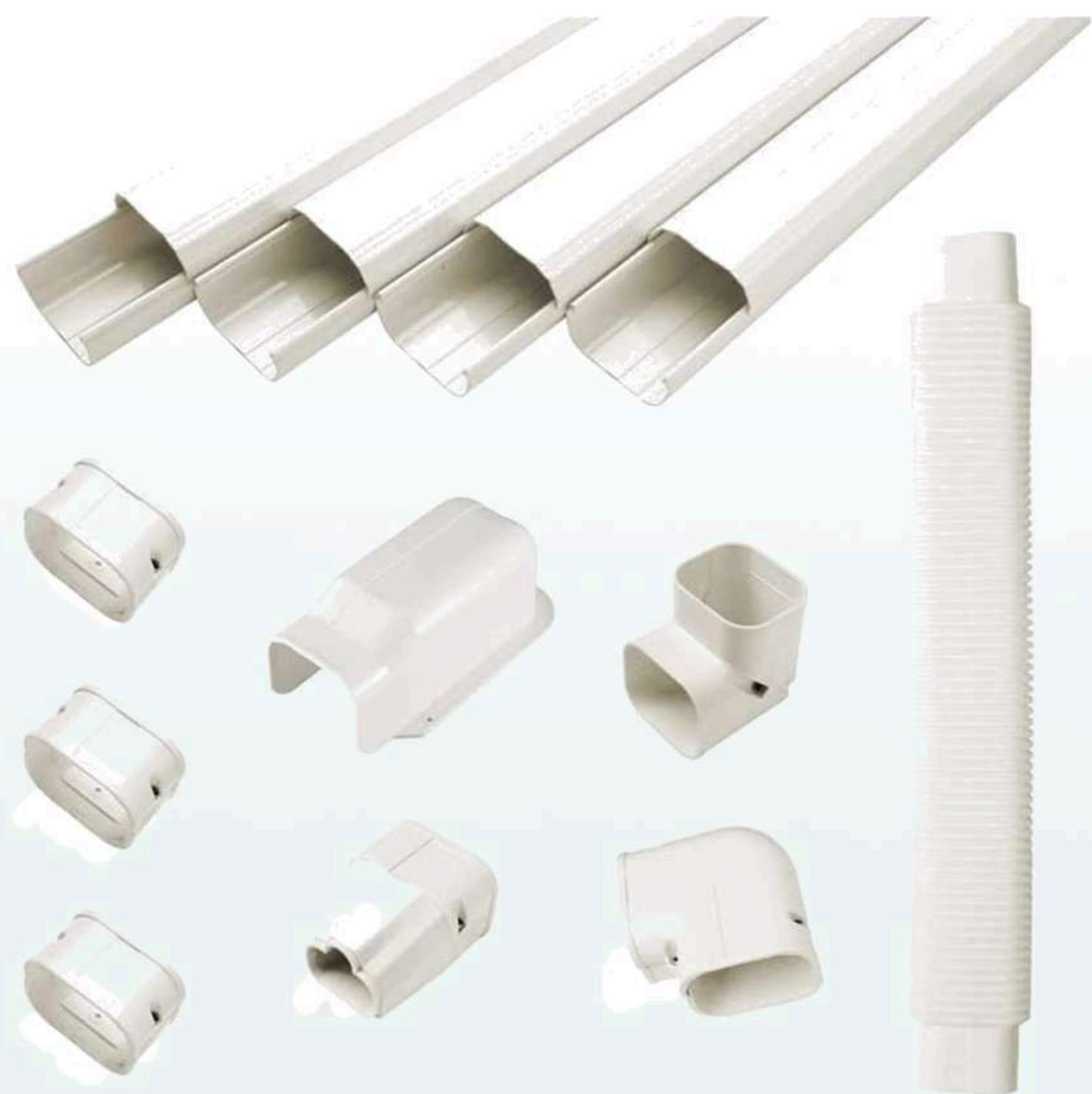

- High Quality Decorative PVC Line Set Cover Kit
- Simple Installation
- Suitable for most 6,000-48,000 BTU Mini Split AC, Central AC system, or Heat Pump
- Made of paintable anti-aging PVC material
- Protects the Piping and Wiring and can help Increase the service life of system

Item includes:

4 – pieces 39”L Straight 3”W

3 – pieces Coupler

1 – piece Entry Wall Cover

1 – piece Reducer End Cap

1 – 90° piece Flat Elbow

1 – 90° piece Elbow

1 – piece flexible pipe

Hardware is included in the packaging .



Wall Cover



Straight Duct



Flat Elbow



Coupler

PACKAGE



SKU: LCK-4M14F

Category: Miscellaneous

NAHVAC reserves the right to change the specifications of the product, and to withdraw or replace products without prior notification or public announcement. NAHVAC is constantly developing and improving its products.



M-Station

Model: MTL04-1

Your Smart Home

Smart Control with Midea Communicating Thermostat & SmartHome App

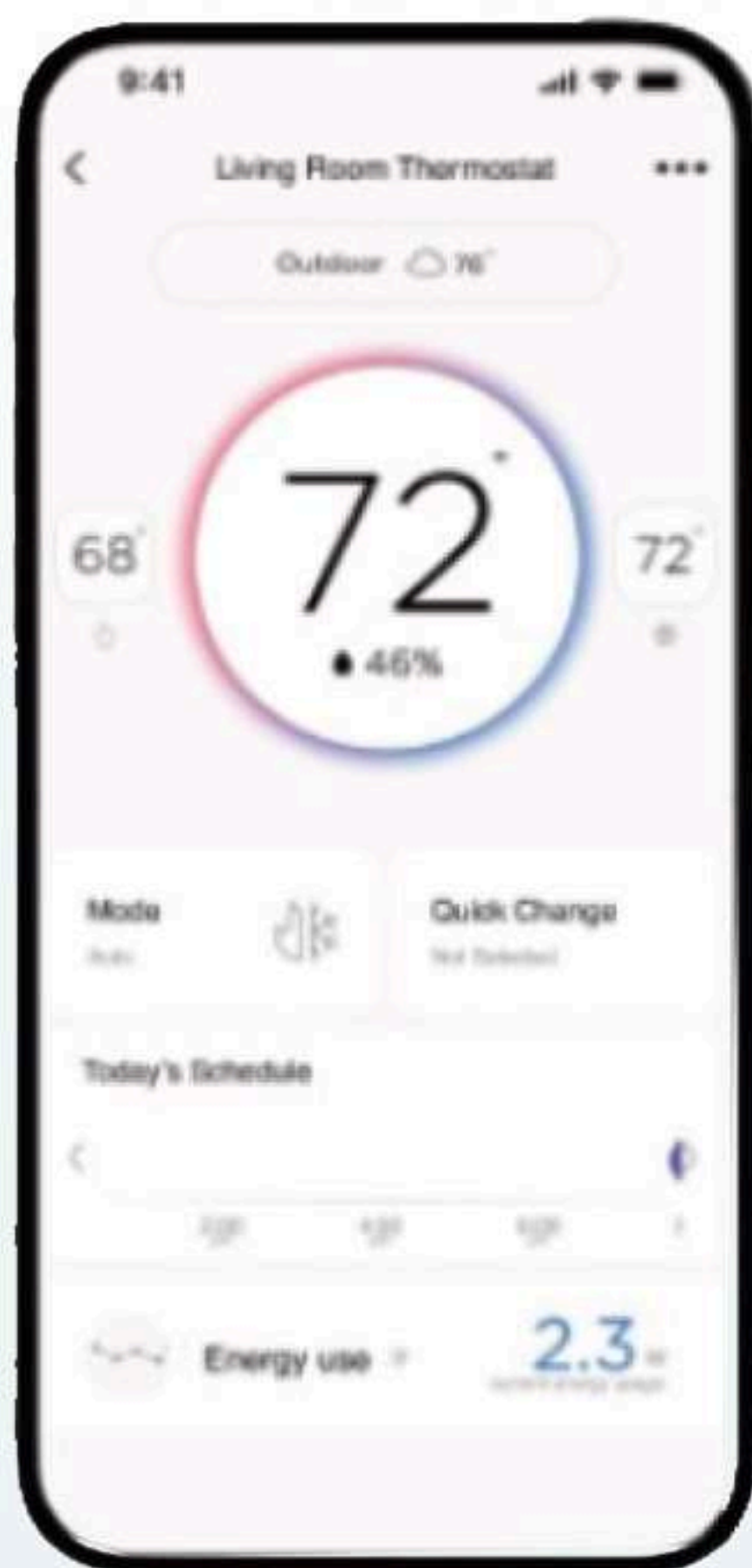

SmartHome App



Next-Gen
Communicating
Thermostat

Set your Schedule



Customize your specific comfort Schedule

Manage your comfort

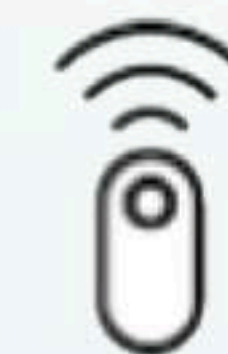

Enjoy your desired air flow, temperature, and relative humidity at home

Keep an eye on your electricity usage



Take a look at your power consumption at any time

Included In The Box:



Smart Thermostat

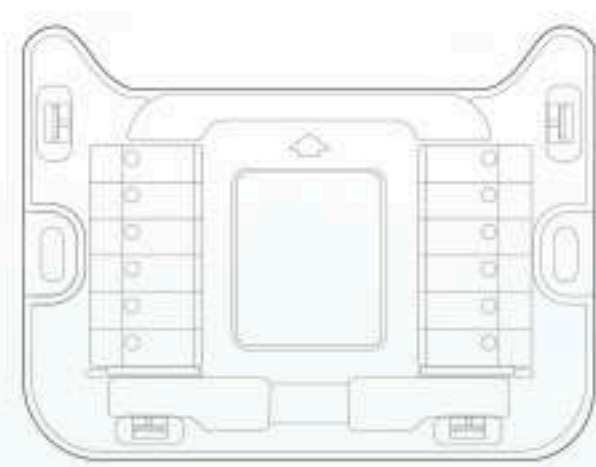

M-base



Trim Plate



Installation &
User Manual



Wire Labels



2 Screws & 2 Anchors

Product Information

Construction of Control: Independently Mounted Control

Operation Method: Type 1 Action

Pollution Degree: 2

Purpose of Control: Operation Control

Protection Class: IP00

Ambient operating Temperature: 32-95°F (0-35°C)

Storage Temperature: -40-140°F (-40-60°C)

Compatibility

This unit works with specific communication systems by HA & HB and most 24V systems.

For communication, HA & HB are communication non-polarity.

For 24V, it can control: Heating 1,2 stages(W1, W2); Cooling 1,2 stages(Y1,Y2); Heat Pump with auxiliary and emergency heat(O/B, W1, W2); Fan(G); Power(R/Rc, Rh, C).