

SUBMITTAL DATA SHEET



Series Name: Extreme Heat AHU Series
Model Number: DLCURAH36ABK / DLFUAAH36XAK

Wall Mounted Heat Pump System

Location:	Approval:
Engineer:	Date:
Submitted to:	Construction:
Submitted by:	Unit #:
Reference:	Drawing #:



INDOOR SPECIFICATION

Indoor Air Flow (H/M/L) (CFM)	1188.24/1082.35/970.59/864.71	
Indoor Noise Level (H/M/L) (dBA)	49/44/42	
Dimension (WxDxH)	inch	21 x 21 x 49
	mm	534 x 534 x 1245
Package (WxDxH)	inch	26-5/8 x 24-3/8 x 52-1/2
	mm	675 x 620 x 1335
Net/Gross Weight	lbs	129/156
	kg	58.6/70.6

OUTDOOR SPECIFICATION

Compressor Type	ROTARY	
Refrigerant	R410A	
Factory Charge	1460±15ml	
Refrigerant Oil	VG74	
Outdoor Air Flow (Max) (CFM)	3035	
Outdoor Noise Level (dBA)	65	
Dimension (WxDxH)	inch	37-1/2 x 16-3/8 x 52-1/2
	mm	952 x 415 x 1333
Package (WxDxH)	inch	43-1/8 x 19-1/2 x 58-1/4
	mm	1095 x 495 x 1480
Net/Gross Weight	lbs	227/256
	kg	0.89

EFFICIENCY

Cooling		Heating	
SEER2	16.0	HSPF2-4	9.5
EER2	10.0	COP	3.4

PERFORMANCE of Cooling

Cooling (Btu/hr)	
Rated Capacity	36000
Min/Max Capacity	13000-47400
Moisture Removal	3.49 L/H (7.4pint/H)
Standard Operating Range	5°F-122°F (-15°C-50°C)
Rated Cooling Conditions:	Indoor: 80°F DB/67°F WB Outdoor: 95°F DB/75°F WB

PERFORMANCE of Heating

Heating (Btu/hr)	
1. @ 47°F Rated (Min/Max)	40000(11000-57200)
2. @ 17°F Rated	30500
3. @ 5°F Max: Capacity / COP	34400 / 1.97
Standard Operating Range	-22°F-75°F (-30°C-24°C)
1. Rated Heating Conditions:	Indoor: 70°F DB/60°F WB Outdoor: 47°F DB/43°F WB
2. Rated Heating Conditions:	Indoor: 70°F DB/60°F WB Outdoor: 17°F DB/15°F WB
3. Heating Conditions, Compressor Operating at Max. Frequency	Indoor: 70°F DB/60°F WB Outdoor: 5°F DB/5°F WB

ELECTRICAL

Power Supply	208/230V, 1Ph, 60Hz
System MCA	30/5
Connection Wiring	AWG 14-2
System MOCP	35/15
Compressor RLA	32
Outdoor Fan Motor RLA	1.2
Outdoor Fan Motor W	85
Indoor Fan Motor RLA	4
Indoor Fan Motor W	/
System Power Input @ Cooling (W)	3673(462-5700)
System Power Input @ Heating (W)	3448(593-5700)
Recommended breaker size(A)	30/15
MCA: Min. circuit amps (A)	MOCP: Max. over current protection (A)
RLA: Rated load amps (A)	W: Fan motor rated output (W)

PIPING

Liquid Size	3/8in (9.52mm)
Gas Size	3/4in (19mm)
Drain Size	5/8in (15.88mm)
Max. Piping Length	213.25ft (65m)
Max. Height Difference	98.42ft (30m)
Max. Pre-charged Length	25ft (7.5m)
Refrigerant Pre-charged Amount	141.1oz (4000g)
Additional Charge of Refrigerant	0.69oz/ft (65g/m)
Connection Method	Flared

Indoor Unit Dimension

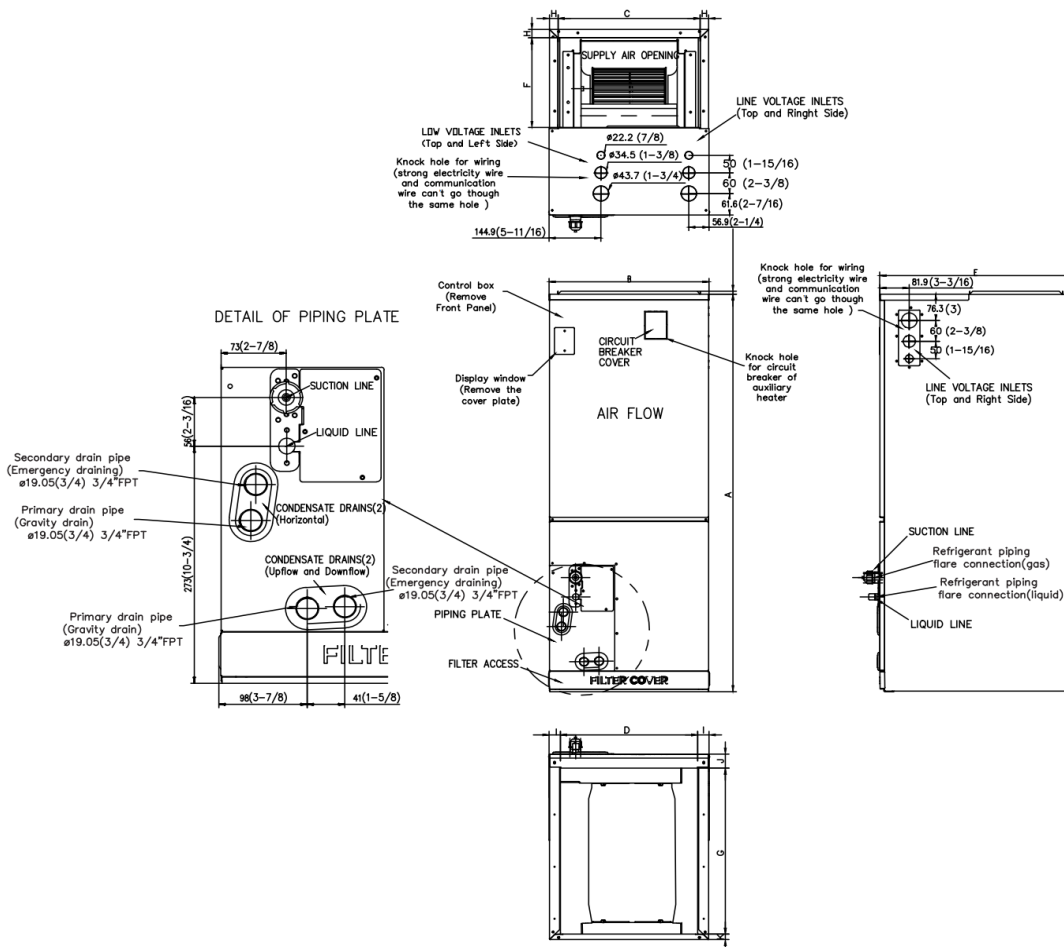

Dimensions	Model	18k/24k		30k/36k		48k/60k	
		inch	mm	inch	mm	inch	mm
A	Model Height	45	1143	49	1245	53	1346
B	Model Width	17-1/2	445	21	534	24-1/2	622
C	Supply Air Opening Width	15-5/8	397	19-1/8	486	22-5/8	575
D	Return Air Opening Width	15-1/8	384	18-5/8	473	22-1/8	562
E	Model Depth	21	534	21	534	21	534
F	Supply Air Opening Depth	10-1/4	260	10-1/4	260	10-1/4	260
G	Return Air Opening Depth	18-3/4	476	18-3/4	476	18-3/4	476
H	Supply Air Opening Clearance	15/16	24	15/16	24	15/16	24
I	Return Air Opening Side Clearance	1-1/4	32	1-1/4	32	1-1/8	28
J	Return Air Opening Front Clearance	1-1/2	38	1-5/8	41	1-5/8	41
K	Return Air Opening Back Clearance	5/8	16	5/8	16	3/4	19

Fan Performance

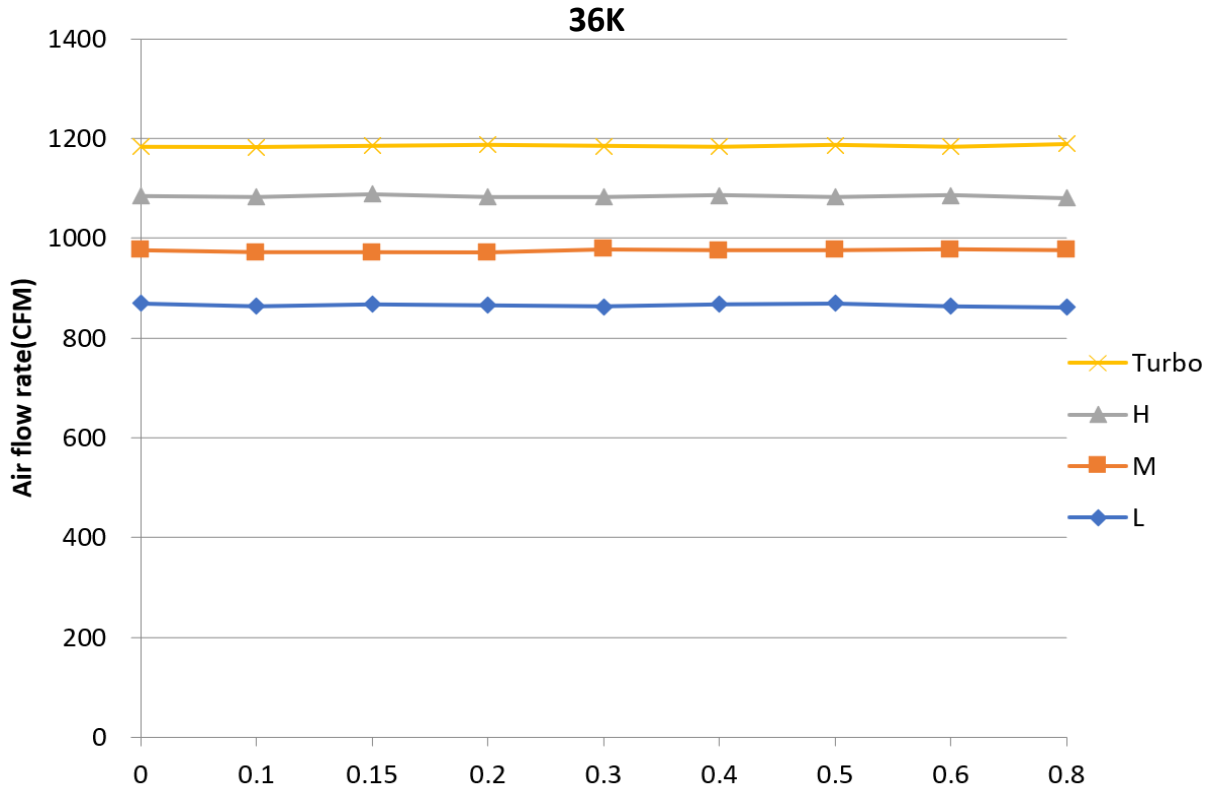

Outdoor Unit Dimension

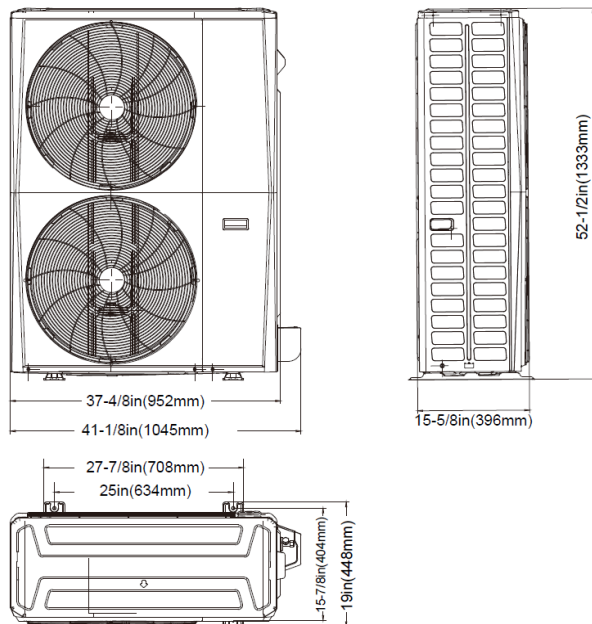

Installation Instruction

REQUIRED CLEARANCE

*1 20in. (500mm) or more when front and sides of the unit are clear

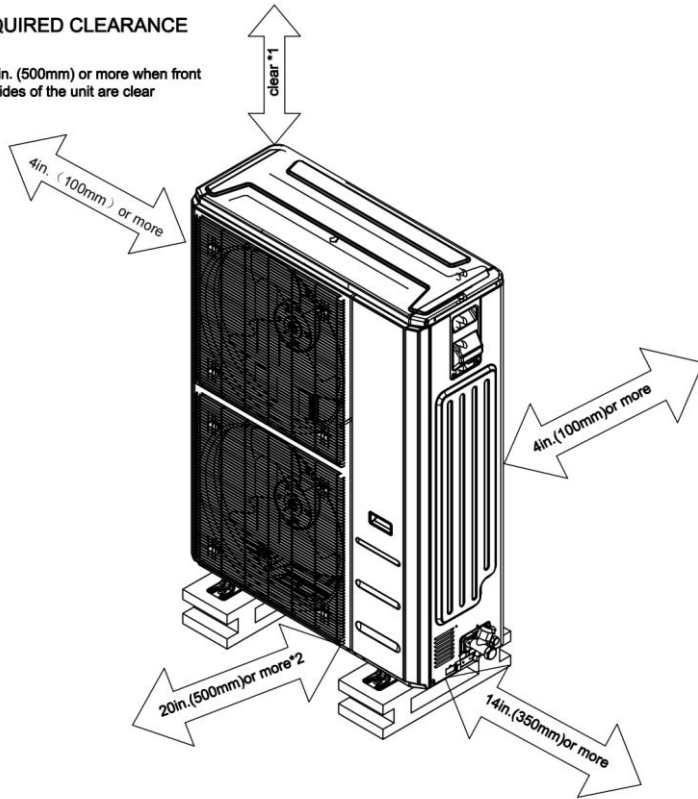

*2 When any 2 sides of left, right and rear of the unit are clear

North American HVAC Products Ltd.

Add.: #100 5118 N Fraser Wy, Burnaby, BC V5J 0H1

Tel: 604-430-8496 info@nahvac.com www.nahvac.com

Midea reserves the right to change the specifications of the product, and to withdraw or replace products without prior notification or public announcement. Midea is constantly developing and improving its products.