

SUBMITTAL DATA SHEET



Series Name: Electric Heater
 Model Number: EAH-05D(UL)

Heater

Location: _____
 Engineer: _____
 Submitted to: _____
 Submitted by: _____
 Reference: _____

Approval: _____
 Date: _____
 Construction: _____
 Unit #: _____
 Drawing #: _____

SPECS

Code	22013201000002	
Model	EAH-05D(UL)	
Normal Operational Voltage	(V, Ph, Hz)	208/230, 1, 60
Current	A	18.5/20.0
Heat Power	kW	3.76/4.54
MCA	A	23.5/25.0
MAX. FUSE	A	25.0/30.0
Heater dimension	mm	730 x 99 x 190
	inch	28.74 x 3.90 x 7.48
Packaging dimension	mm	805 x 315 x 165
	inch	31.69 x 12.40 x 6.50
Net Weight	kg	1.8
	lbs	4.0
Gross Weight	kg	4.6
	lbs	10.14



Heater dimension

unit: Inch (mm)

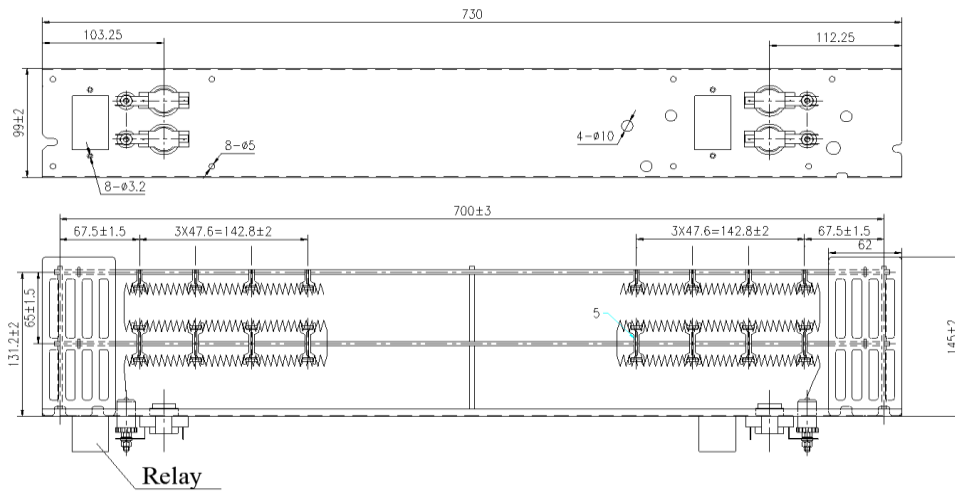

Wiring diagram

3KW/5KW/8KW/10KW HEAT KIT

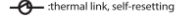
-  thermal cut-out
-  thermal link, self-resetting

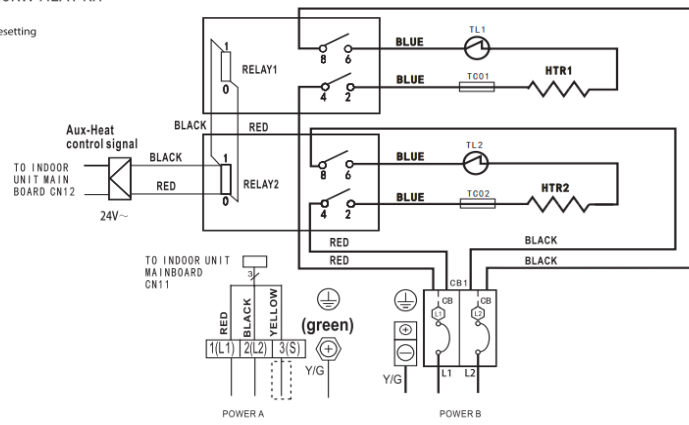

NOTE 1: 
 This symbol indicates the element is optional. The wiring type of the actual unit shall prevail.

NOTE 2:
 Please attach the nameplate to the cover of the electric control box.
 Please refer to the Installation Manual for details.

NOTE 3:
 TO BE WIRED IN ACCORDANCE WITH NEC AND LOCAL CODES.

NOTE 4:
 POWER A, B, C, D ARE DIFFERENT POWERS.

The wiring mode of power supply A shall be based on the type of original wiring terminal of AHU; for type A, S position must be connected to the outdoor S; for type B, S position shall not be connected.



North American HVAC Products Ltd.

Add.: #100 5118 N Fraser Wy, Burnaby, BC V5J 0H1

Tel: 604-430-8496 info@nahvac.com www.nahvac.com

Midea reserves the right to change the specifications of the product, and to withdraw or replace products without prior notification or public announcement.
Midea is constantly developing and improving its products.