

A2L 96% AFUE Gas Furnace

Troubleshooting Guide

Table of Contents

1	Key to Symbols and Safety Instructions	4
1.1	Key to Symbols	4
1.2	Safety	4
2	Troubleshooting	6
2.1	Electrostatic Discharge (ESD) Precautions	6
2.2	Resetting From Lockout	6
3	Error Codes	7
3.1	No Flash and No Fan (System Does Not Start Normally)	7
3.2	E7 System Lock-Out due to Failed Ignition E8 System Lock-Out due to too Many Flame Dropouts	10
3.3	E1 Low Fire Pressure Switch Stuck Closed	12
3.4	E2 Low Pressure Switch Stuck Open E4 Pressure Switch Cycle Lockout E3 High Pressure Switch Stuck Open	14
3.5	E5 Limit/Rollout Switch Open Less than 5 Mins E6 Limit/Rollout Switch Open More than 5 Mins	16
3.6	Pr Incorrect Polarity of L1/L2	20
3.7	FL Low Flame	21
Appendix A	Sequence of Operation	22
	Two Stage Controller Logic	22
A1	Heating Modes	23
	A1.1 Low Fire Heating Mode Logic (only W1 signal):	23
	A1.2 High Fire Heating Mode Logic (W1+W2 Signal):	24
A2	Ignition Failure and Reignition Sequence	25
A3	Requirements for refrigerant leakage sensors	26

1 Key to Symbols and Safety Instructions

1.1 Key to Symbols

Warnings



Warnings in this document are identified by a warning triangle printed against a grey background.

Keywords at the start of a warning indicate the type and seriousness of the ensuing risk if measures to prevent the risk are not taken.

The following keywords are defined and can be used in this document:

- ▶ **DANGER** indicates a hazardous situation which, if not avoided, will result in death or serious injury.
- ▶ **WARNING** indicates a hazardous situation which, if not avoided, could result in death or serious injury.
- ▶ **CAUTION** indicates a hazardous situation which, if not avoided, could result in minor to moderate injury.
- ▶ **NOTICE** is used to address practices not related to personal injury.

Important information



This symbol indicates important information where there is no risk to people or property.

1.2 Safety

Please read all instruction in the manual and retain all manuals for future reference.



WARNING:

- ▶ Untrained personnel (homeowners) may only clean and replace filters and replace fuses as required by basic maintenance. **All other operations, including installation, repair, and service must be performed by a qualified installer, service agency, or the gas supplier.**



WARNING: FIRE OR EXPLOSION HAZARD

- ▶ Do not store or use gasoline or other flammable vapors and liquids in the vicinity of this or any other appliance.
- ▶ WHAT TO DO IF YOU SMELL GAS:
 - Do not try to light any appliance.
 - Do not touch any electrical switch; do not use any phone in your building.
 - Leave the building immediately.
 - Immediately call your gas supplier from a neighbor's phone. Follow the gas supplier's instructions.
 - If you cannot reach your gas supplier, call the fire department.
- ▶ Installation and service must be performed by a qualified installer, service agency, or the gas supplier.



WARNING:

- ▶ Do not use this furnace if any part has been under water. A flood-damaged furnace is extremely dangerous. Attempts to use the furnace can result in fire or explosion. A qualified service agent must inspect the furnace and replace all gas controls, control system parts, and electrical parts that have been wet, or the furnace if deemed necessary.



WARNING: FIRE OR EXPLOSION HAZARD

- ▶ The furnace is designed and approved for use with Natural Gas and Propane (LP) Gas ONLY.
- ▶ DO NOT BURN ANY LIQUID FUEL OR SOLID FUEL IN THIS FURNACE.
- ▶ Burning any unapproved fuel will result in damage to the furnace's heat exchanger, which could result in Fire, Personal Injury, and/or Property Damage.



WARNING: FOLLOW ALL SAFETY CODES

- ▶ Wear safety glasses, protective clothing, and work gloves. Have a fire extinguisher available. Read these instructions thoroughly and follow all warnings or cautions included in literature and attached to the unit. Consult local building codes as well as the current editions of the National Fuel Gas Code (NFGC) NFPA 54/ANSI Z223.1 and the National Electrical Code (NEC) NFPA 70.



WARNING: FIRE, EXPLOSION

- ▶ Check entire gas assembly for leaks after lighting this appliance.
- ▶ Never test for gas leaks with an open flame. Use a commercially available soap solution made specifically for the detection of leaks to check all connections, as specified in the Installation, Operation, and Maintenance Manual.



WARNING: FIRE, EXPLOSION, ELECTRICAL SHOCK, AND CARBON MONOXIDE POISONING HAZARD

- ▶ Failure to follow this warning could result in dangerous operation, serious injury, death, or property damage. Improper installation, adjustment, alteration, maintenance, or use could cause carbon monoxide poisoning, explosion, fire, electrical shock, or other conditions which may cause personal injury or property damage. Consult a qualified service agency, local gas supplier, or your distributor for information or assistance.



WARNING: FIRE, EXPLOSION

- ▶ See instructions for lighting/shutdown operation (as shown on a sticker directly on the inside of the furnace panel). Should the gas supply fail to shut off or if overheating occurs, shut off the gas valve to the furnace before shutting off the electrical supply.



WARNING: FIRE HAZARD

- ▶ The furnaces must be kept free and clear of insulating materials. Inspect surrounding area to ensure insulation material is at a safe distance when installing furnaces or adding insulation materials. Insulation materials may be combustible.
 Maintain a 1 in. clearance from combustible materials to supply air ductwork for a distance of 36 in. horizontally from the furnace. See NFPA 90B or local code for further requirements.
- ▶ These furnaces SHALL NOT be installed directly on carpeting, tile, or any other combustible material other than wood flooring. In downflow installations, field supplied floor base MUST be used when installed on combustible materials and wood flooring. Special base is not required when this furnace is installed on industry standard Coil Assembly matching correct furnace width.



WARNING:

- ▶ This product can expose you to chemicals including Lead and Lead components, which are known to the State of California to cause cancer and birth defects or other reproductive harm. For more information go to www.P65Warnings.ca.gov.



CAUTION: CUT HAZARD

- ▶ Failure to follow this caution may result in personal injury. Sheet metal parts may have sharp edges or burrs. Use care and wear appropriate protective clothing, safety glasses and gloves when handling parts and servicing furnaces.

2 Troubleshooting



WARNING: FIRE, EXPLOSION AND ASPHYXIATION HAZARD

- ▶ Installation and service must be performed by a qualified service agency or the gas supplier.

Refer to the troubleshooting charts and associated figures on the following pages for assistance in determining the source of unit operational problems. The diagnostic LED blinks to assist in troubleshooting the unit. The number of blinks refers to a specific code.

2.1 Electrostatic Discharge (ESD) Precautions

NOTICE:

- ▶ Discharge body's static electricity before touching unit. An electrostatic discharge can adversely affect electrical components.

Use the following precautions during furnace installation and servicing to protect the integrated control module from damage. By putting the furnace control and the person at the same electrostatic potential these steps will help avoid exposing the integrated control module to electrostatic discharge. This procedure is applicable to both installed and uninstalled (ungrounded) furnaces.

1. Disconnect all power to the furnace. Do not touch the integrated control module or any wire connected to the control prior to discharging your body's electrostatic charge to ground.
2. Firmly touch a clean unpainted metal surface of the furnace away from the control. Any tools held in a person's hand during grounding will be discharged.
3. Service integrated control module or connecting wiring following the discharge process in step 2. Use caution not to recharge your body with static electricity; (i.e. do not move or shuffle your feet, do not touch ungrounded objects, etc.). If you come in contact with an ungrounded object, repeat step 2 before touching control or wires.
4. Discharge your body to ground before removing a new control from its container. Follow steps 1 through 3 if installing the control on a furnace. Return any old or new controls to their containers before touching any ungrounded object.

2.2 Resetting From Lockout

Furnace lockout results when a furnace is unable to achieve ignition after three attempts. Refer to the troubleshooting chart on the following pages for assistance in determining the source of unit operational problems. The red diagnostic LED blinks to assist in troubleshooting the unit. If the furnace is in "lockout" it will (or can be) reset in any of the following ways.

1. Automatic reset. The integrated control module will automatically reset itself and attempt to resume normal operations following a one hour lockout period.
2. Manual power interruption. Interrupt 115 volt power to the furnace for 1 - 20 seconds.
3. Manual thermostat cycle. Lower the thermostat so that there is no longer a call for heat for 1 - 20 sec.

3 Error Flash Codes

3.1 No Light and No Fan (System Does Not Start Normally)

Troubleshooting Chart

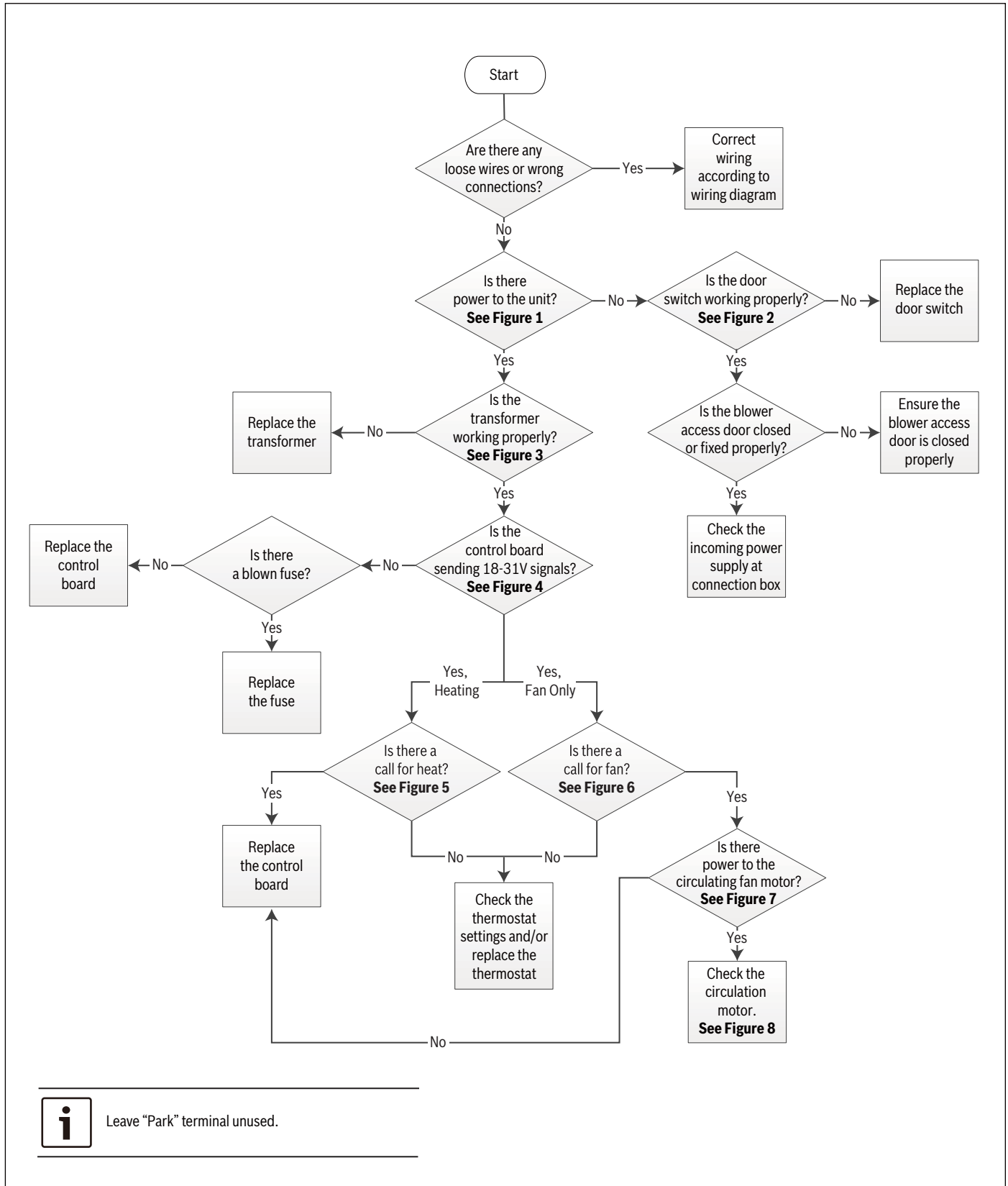

Leave "Park" terminal unused.

No Light and No Fan (System Does Not Start Normally)

Figures & Tables

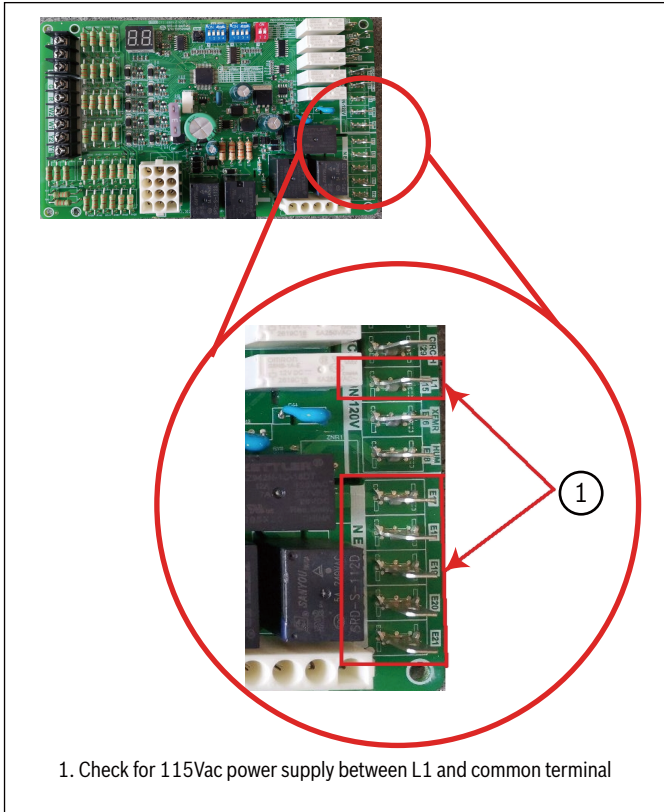

Figure 1

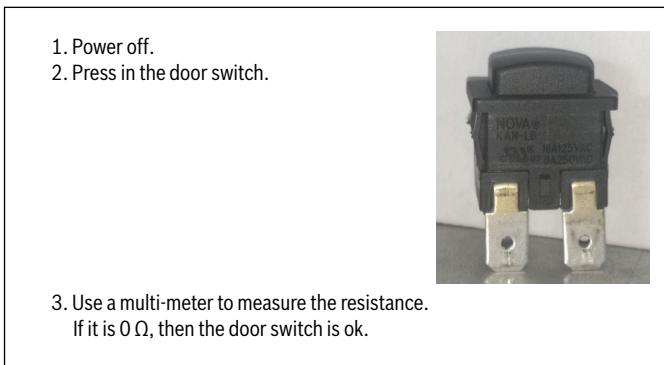

Figure 2



Figure 3

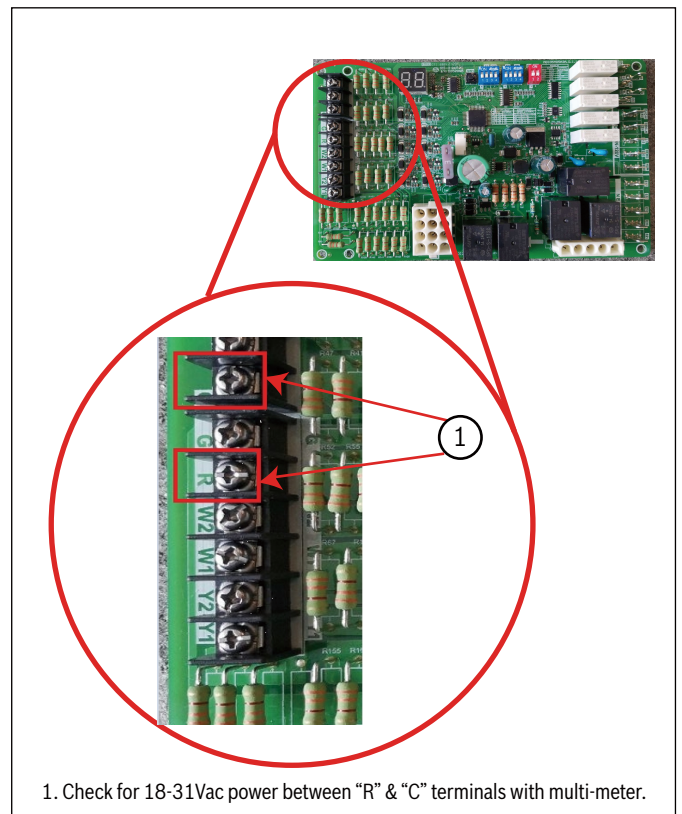

Figure 4

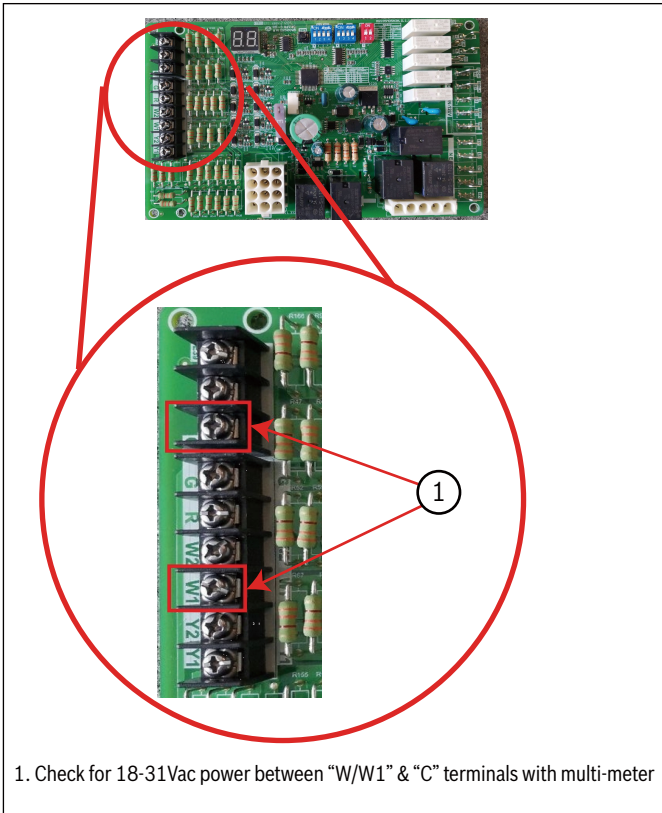

Figure 5

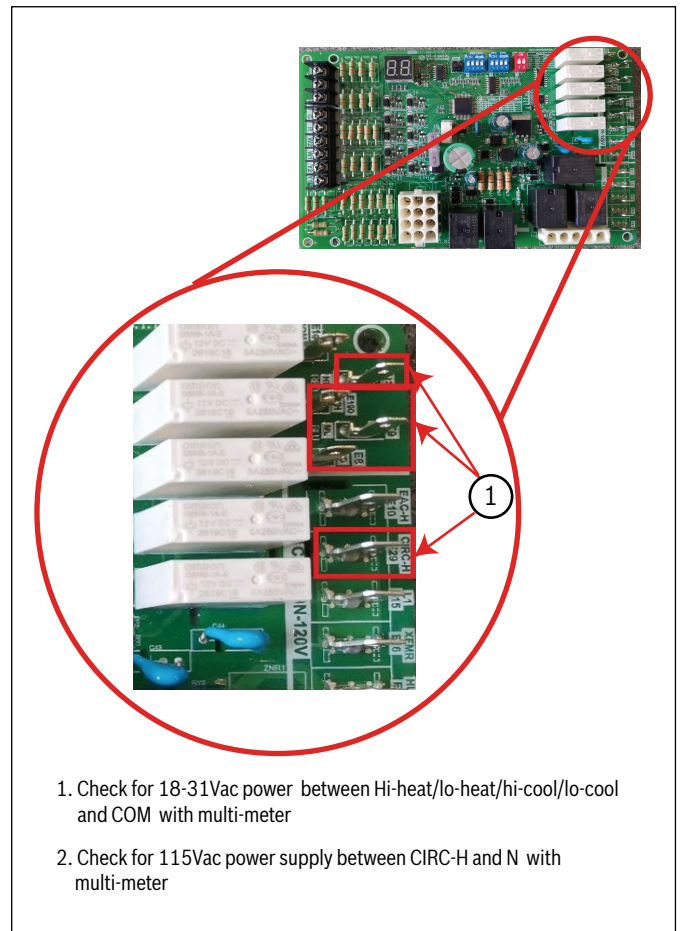

Figure 7

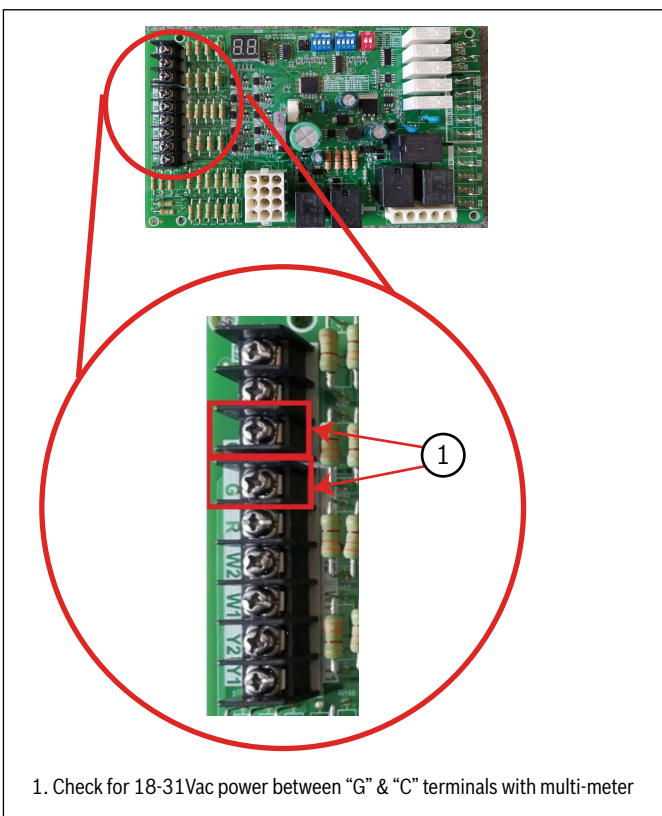

Figure 6

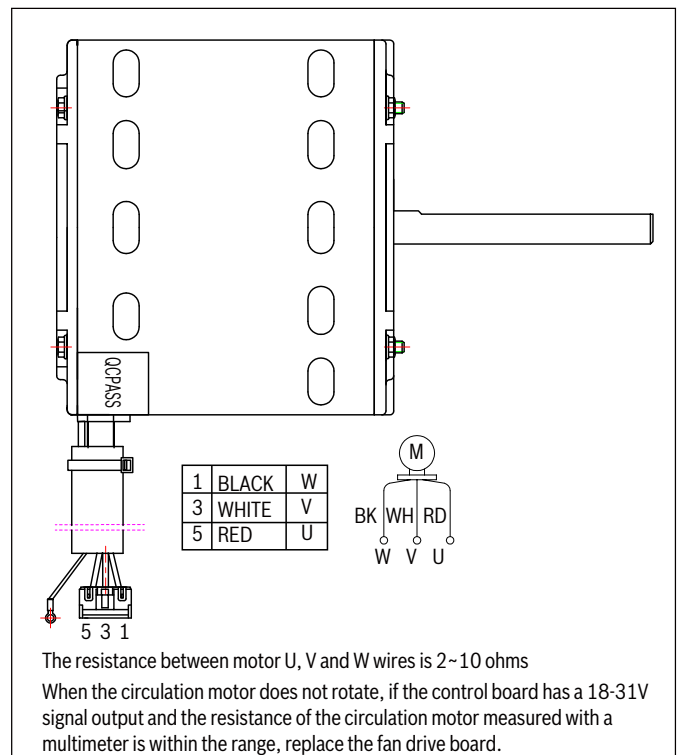
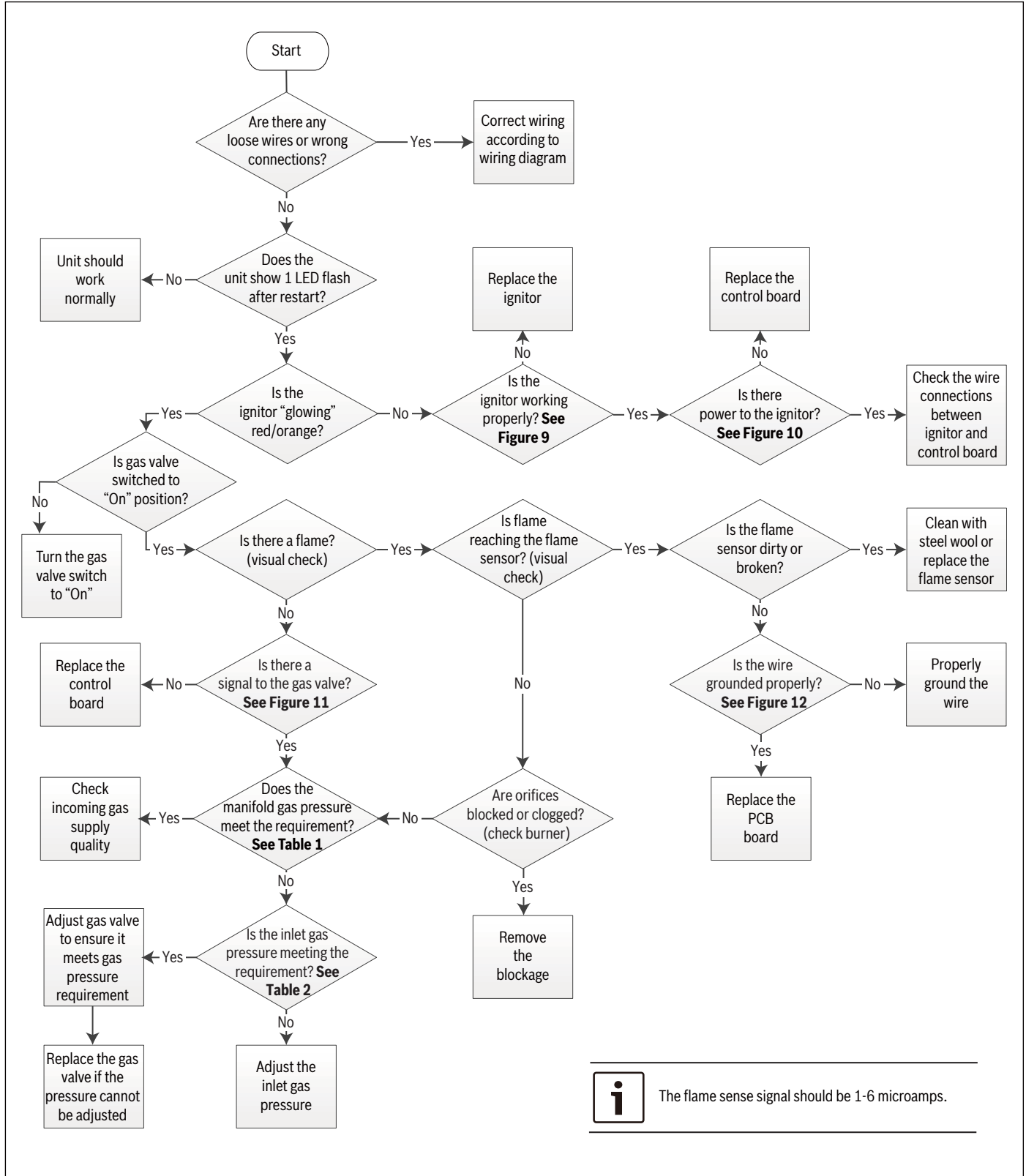

Figure 8

**3.2 E7 (System Lock-Out due to Failed Ignition)
E8 (System Lock-Out due to too Many Flame Dropouts)**

Troubleshooting Chart



The flame sense signal should be 1-6 microamps.

E7 (System Lock-Out due to Failed Ignition)
E8 (System Lock-Out due to too Many Flame Dropouts)

Figures & Tables

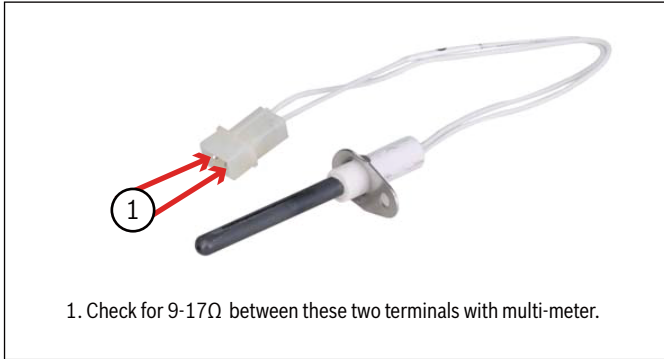

Figure 9

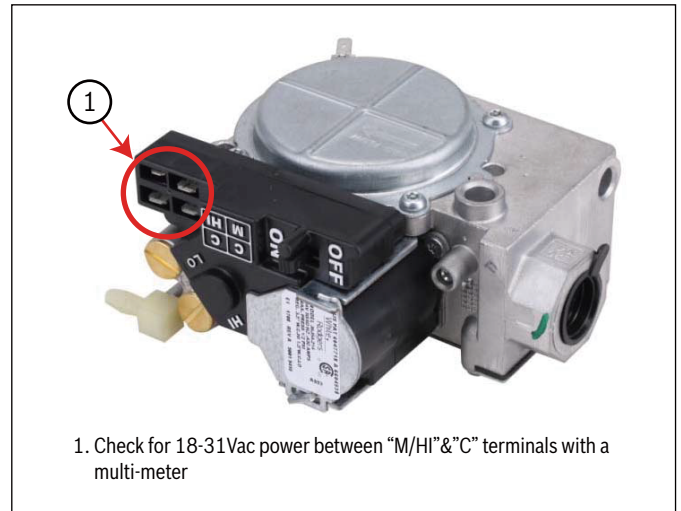

Figure 11

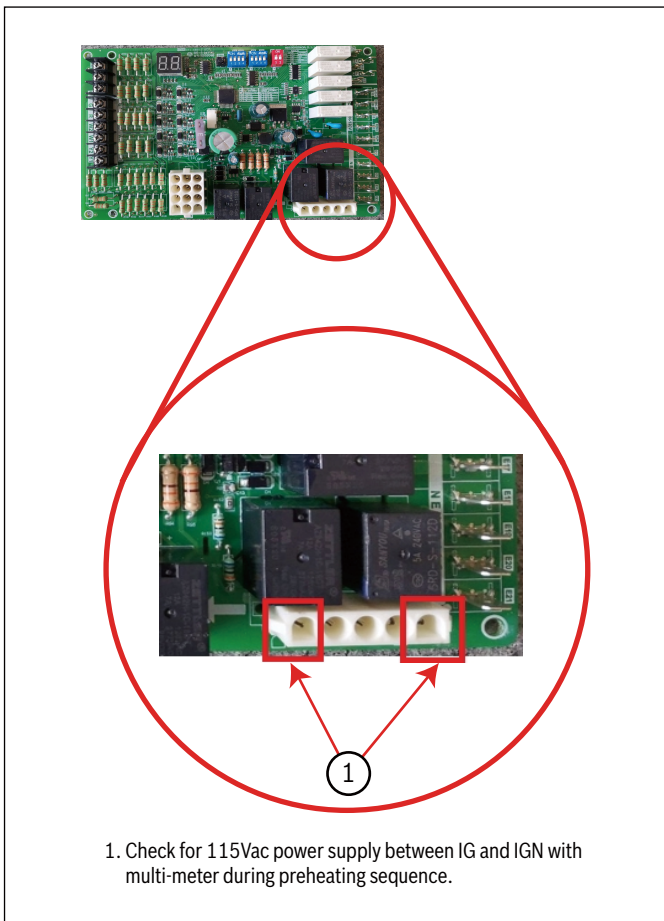

Figure 10

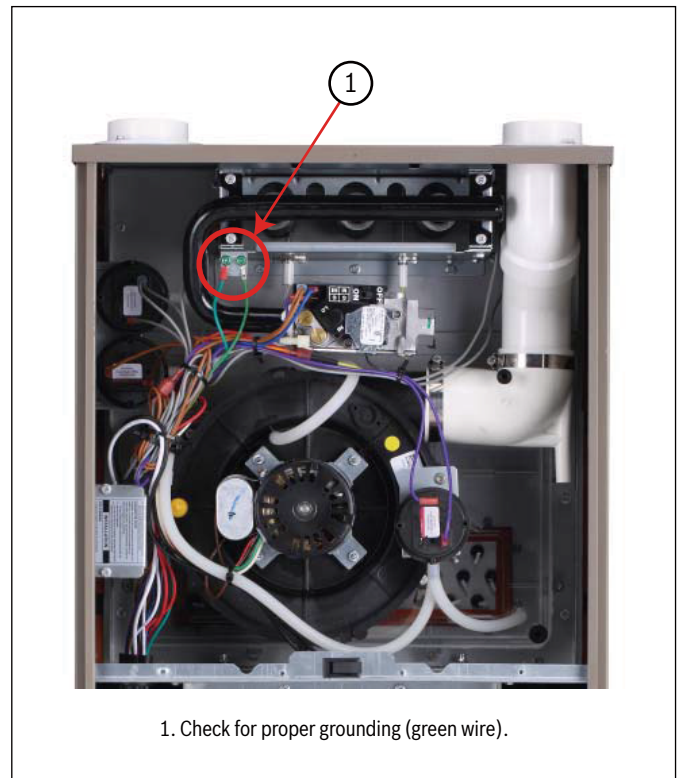

Figure 12

	Manifold Gas Pressure
Natural Gas	3.5 in. W.C.
Propane Gas	10 in. W.C.

Table 1 Manifold Gas Pressure

	Inlet Gas Supply Pressure	
Natural Gas	Minimum: 4.5 in. W.C.	Maximum: 10.5 in. W.C.
Propane Gas	Minimum: 11.0 in. W.C.	Maximum: 13.0 in. W.C.

Table 2 Inlet Gas Supply Pressure

3.3 E1 (Low Fire Pressure Switch Stuck Closed)

Troubleshooting Chart

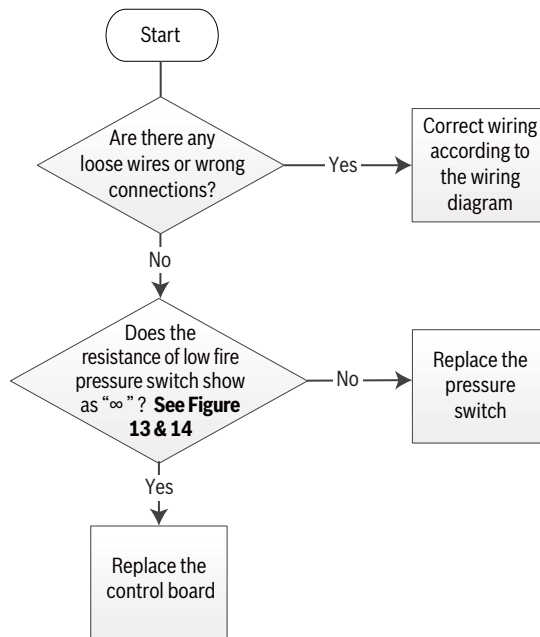

This error could also be caused by a blocked vent. Check vent for obstructions. If a vent is blocked, unit's safety protection logic will turn off unit.

**3.4 E2 (Low Pressure Switch Stuck Open)
E4 (Pressure Switch Cycle Lockout)
E3 (High Pressure Switch Stuck Open)**

Troubleshooting Chart

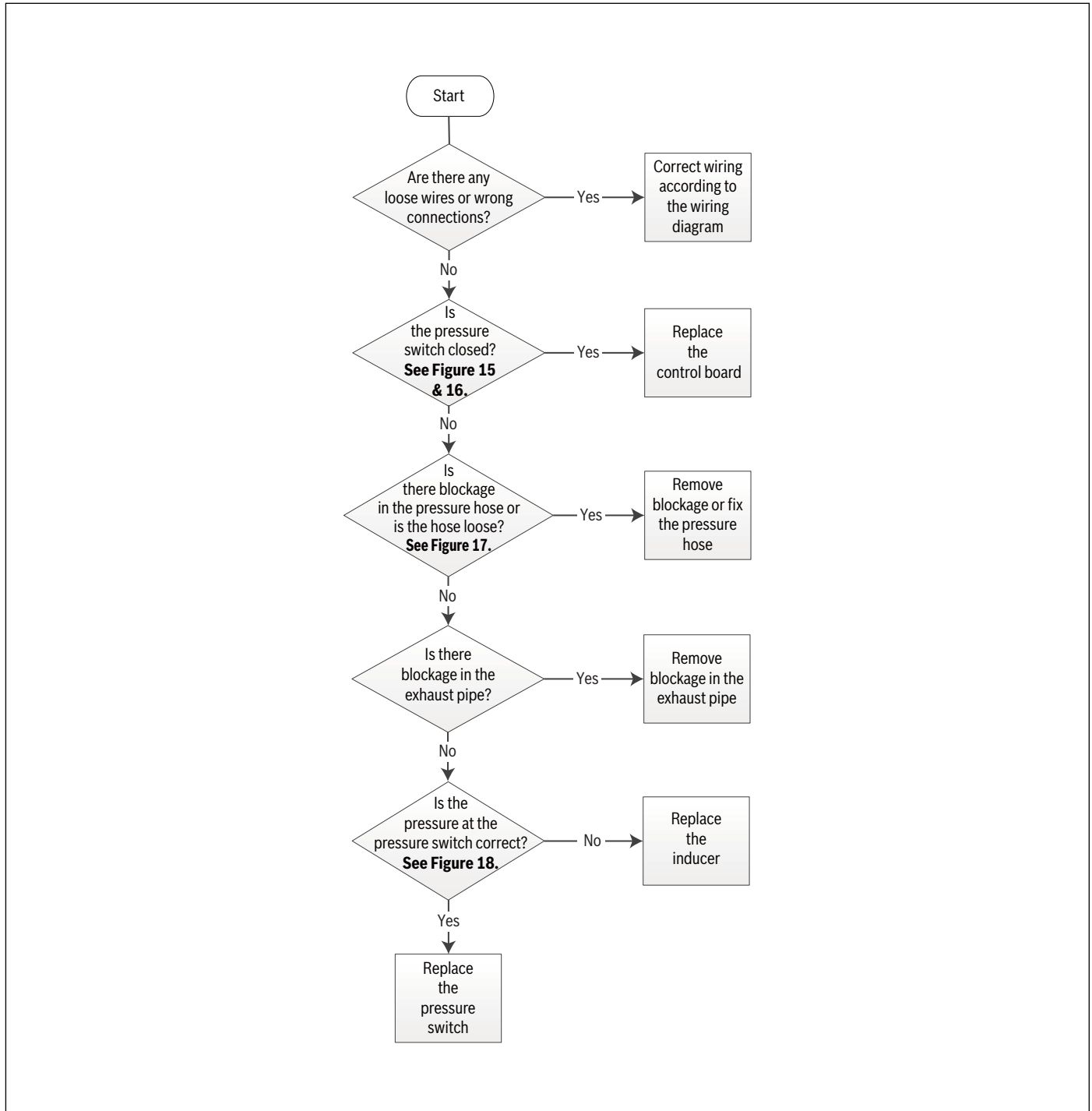

E2 (Low Pressure Switch Stuck Open)
E4 (Pressure Switch Cycle Lockout)
E3 (High Pressure Switch Stuck Open)

Figures

i The pressure switch that you are checking in this step depends on the number of LED flashes. Refer to the specific flashes and their descriptions above.

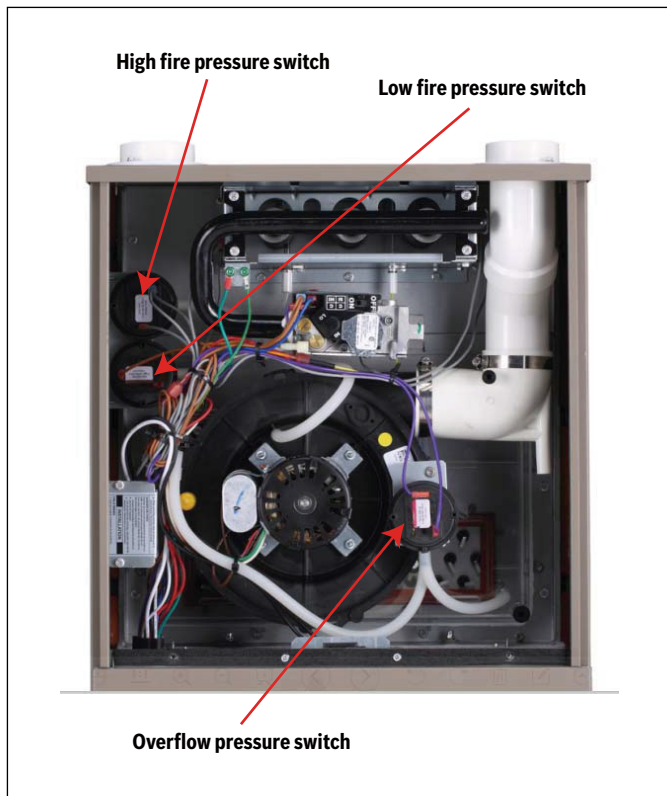

Figure 15

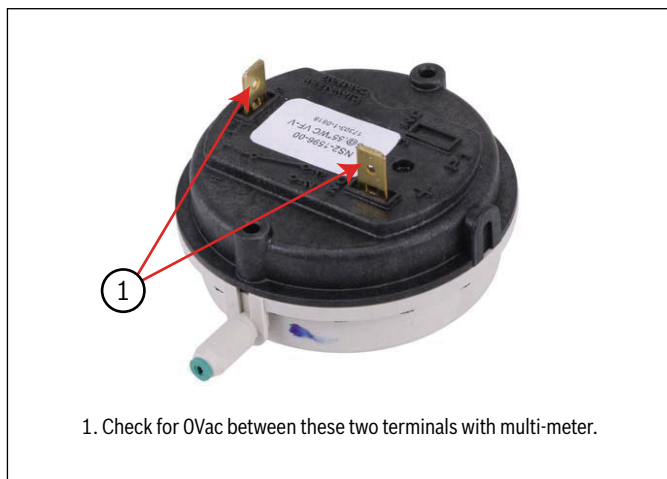

Figure 16

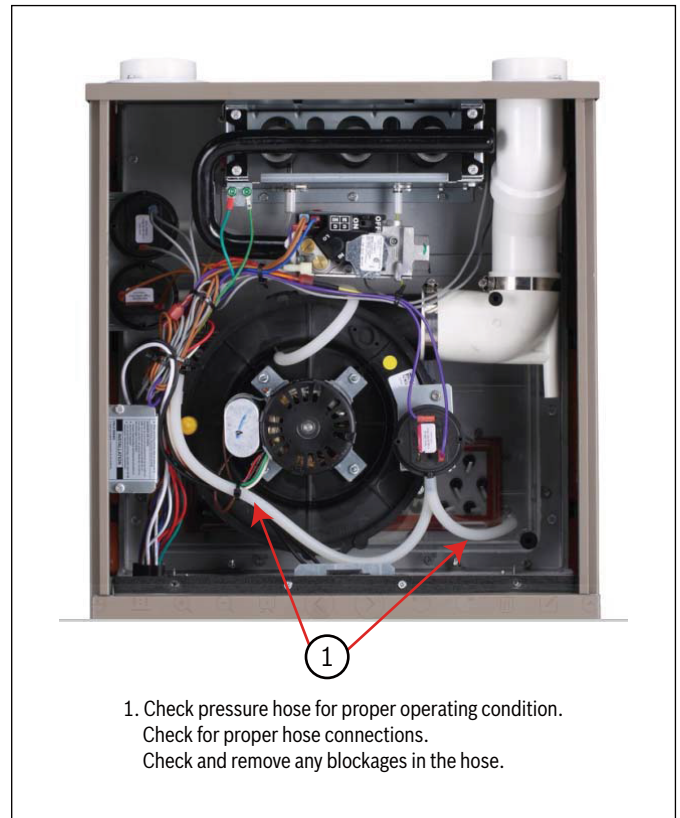

Figure 17

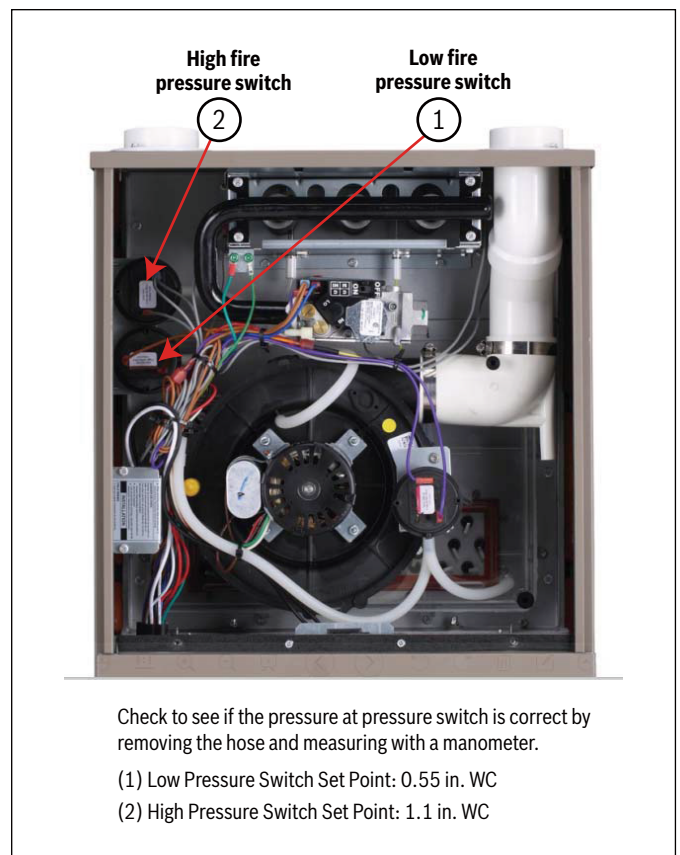
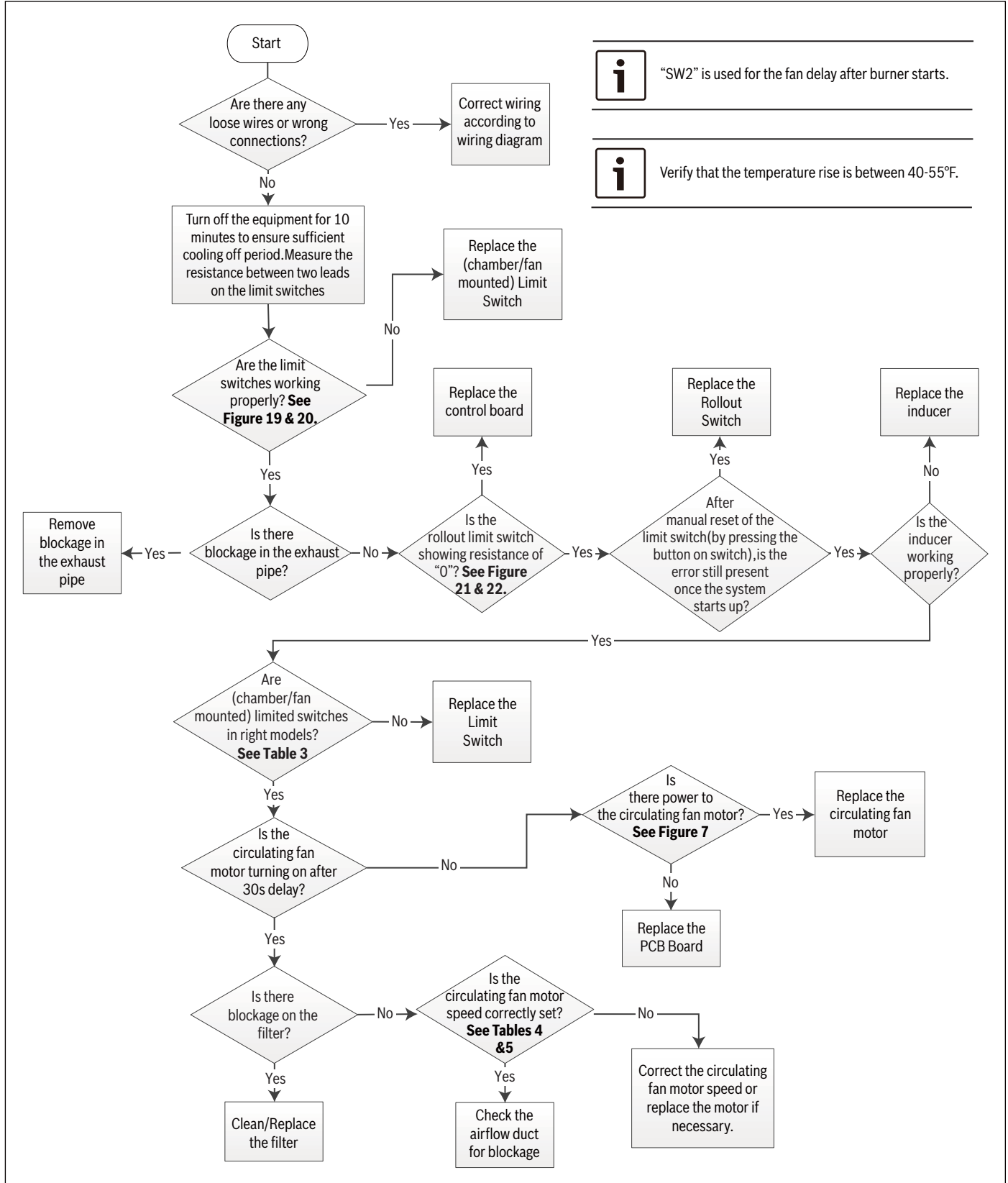

Figure 18

**3.5 E5 (Limit/Rollout Switch Open Less than 5 Mins)
E6 (Limit/Rollout Switch Open More than 5 Mins)**

Troubleshooting Chart



“SW2” is used for the fan delay after burner starts.



Verify that the temperature rise is between 40-55°F.

E5 (Limit/Rollout Switch Open Less than 5 Mins)
E6 (Limit/Rollout Switch Open More than 5 Mins)

Figures & Tables

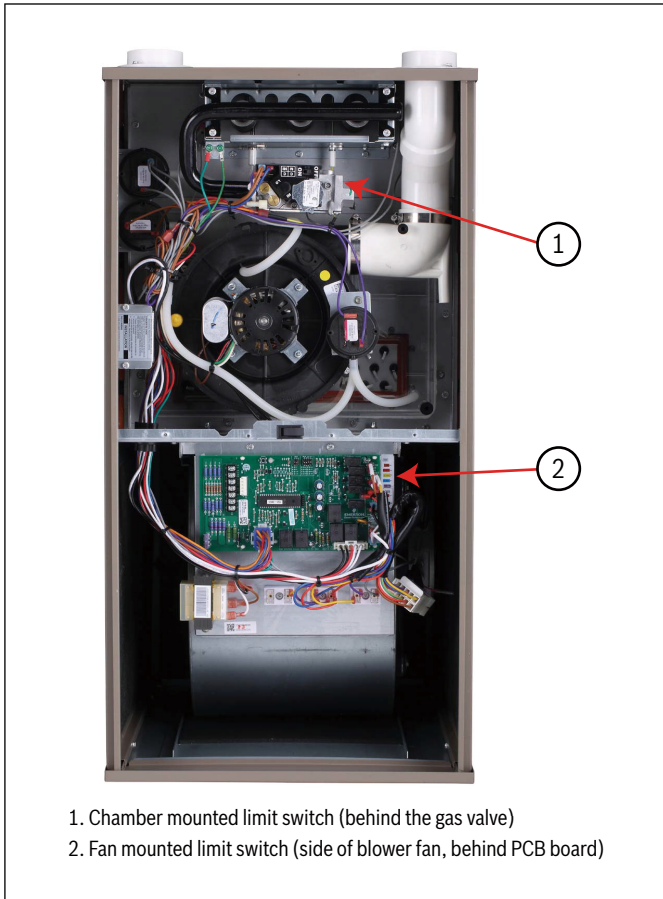

Figure 19

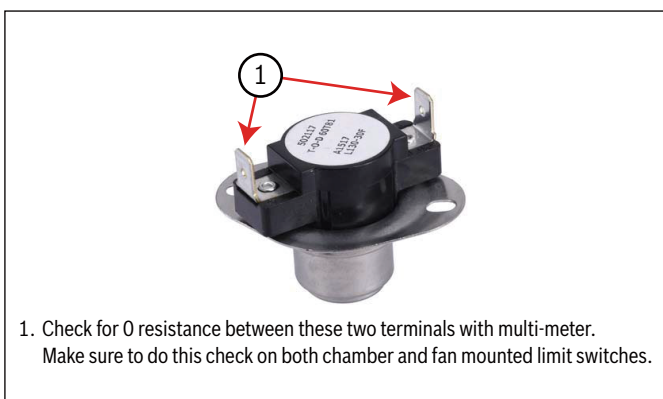

Figure 20

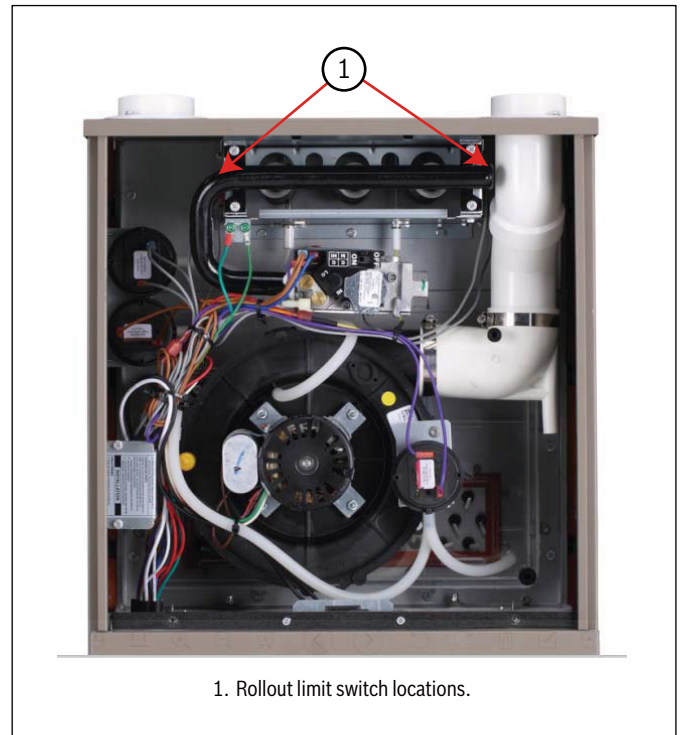

Figure 21

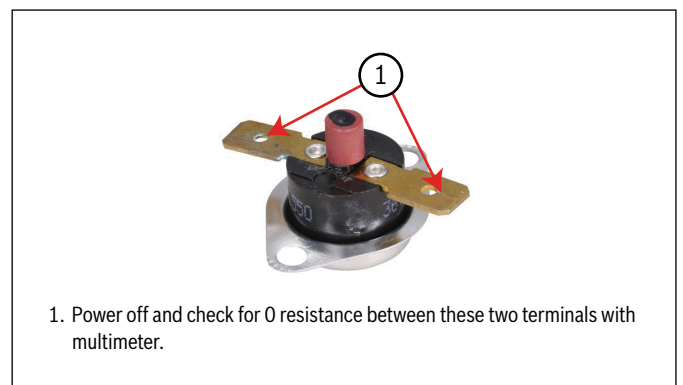

Figure 22

Model	BGH96M060B3A	BGH96M080B3A	BGH96M080C4A	BGH96M100C5A	BGH96M100D5A	BGH96M120D5A
Rollout switch - resettable	—	°F	300			
Inlet High Temperature Limit switch - fixed	Off/On	°F	150/120	150/120	150/120	150/120

Table 3

Furnace size	Return-air inlet	Speed		External static pressure (in. WC)											
				0.1	0.2	0.3	0.4	0.5	0.6	0.7	0.8	0.9	1.0		
60B	Bottom or Sides	H	CFM	1339	1327	1338	1309	1321	1320	1342	1334	1316	1335		
			Temp Rise-1st stage °F	--	--	--	--	--	--	--	--	--	--	--	
			Temp Rise-2nd stage °F	37.3	37.7	37.5	38.3	38.1	38.1	37.6	37.9	38.5	38.0		
		Mid-H	CFM	1124	1118	1102	1106	1096	1099	1102	1109	1089	1105		
			Temp Rise-1st stage °F	--	--	--	--	--	--	--	--	--	--		
			Temp Rise-2nd stage °F	44.2	44.5	45.2	45.1	45.6	45.5	45.5	45.3	46.2	45.6		
		Mid	CFM	880	870	853	858	865	858	854	866	871	839		
			Temp Rise-1st stage °F	36.7	37.2	37.9	37.8	37.6	38.0	38.2	37.8	37.6	39.1		
			Temp Rise-2nd stage °F	56.3	57.0	58.1	57.9	57.5	58.0	58.4	57.7	57.4	59.7		
		Mid-L	CFM	779	768	762	756	740	753	757	747	785	766		
			Temp Rise-1st stage °F	41.4	42.0	42.4	42.8	43.8	43.1	43.0	43.6	41.6	42.7		
			Temp Rise-2nd stage °F	--	--	--	--	--	--	--	--	--	--		
		Low	CFM	553	586	543	569	552	562	584	572	575	567		
			Temp Rise-1st stage °F	58.1	54.9	59.3	56.7	58.5	57.6	55.5	56.8	56.5	57.4		
			Temp Rise-2nd stage °F	--	--	--	--	--	--	--	--	--	--		
		80B	Bottom or Sides	H	CFM	1230	1233	1222	1226	1214	1236	1255	1244	1249	1251
					Temp Rise-1st stage °F	--	--	--	--	--	--	--	--	--	--
					Temp Rise-2nd stage °F	53.9	53.8	54.4	54.3	54.8	53.9	53.2	53.7	53.6	53.6
Mid-H	CFM			1052	1052	1041	1044	1037	1034	1048	1046	1024	1076		
	Temp Rise-1st stage °F			41.0	41.0	41.5	41.5	41.8	42.1	41.5	41.7	42.7	40.7		
	Temp Rise-2nd stage °F			62.8	62.8	63.6	63.5	64.0	64.3	63.4	63.7	65.1	62.1		
Mid	CFM			849	861	854	853	855	844	855	848	834	859		
	Temp Rise-1st stage °F			50.6	50.0	50.4	50.5	50.5	51.2	50.6	51.2	52.1	50.7		
	Temp Rise-2nd stage °F			--	--	--	--	--	--	--	--	--	--		
Mid-L	CFM			754	771	765	764	728	761	782	739	758	758		
	Temp Rise-1st stage °F			56.9	55.7	56.2	56.3	59.2	56.8	55.3	58.5	57.2	57.3		
	Temp Rise-2nd stage °F			--	--	--	--	--	--	--	--	--	--		
Low	CFM			569	554	571	572	568	572	598	594	572	548		
	Temp Rise-1st stage °F			--	--	--	--	--	--	--	--	--	--		
	Temp Rise-2nd stage °F			--	--	--	--	--	--	--	--	--	--		
80C	Bottom or Sides			H	CFM	1303	1301	1281	1291	1289	1291	1290	1295	1298	1253
					Temp Rise-1st stage °F	--	--	--	--	--	--	--	--	--	--
					Temp Rise-2nd stage °F	50.8	50.9	51.8	51.5	51.6	51.6	51.7	51.6	51.6	53.5
		Mid-H	CFM	1120	1127	1134	1130	1135	1138	1132	1143	1107	1112		
			Temp Rise-1st stage °F	38.5	38.3	38.1	38.3	38.2	38.2	38.5	38.2	39.5	39.4		
			Temp Rise-2nd stage °F	59.0	58.7	58.4	58.7	58.5	58.4	58.8	58.3	60.3	60.1		
		Mid	CFM	908	894	896	902	896	894	864	891	935	880		
			Temp Rise-1st stage °F	47.3	48.1	48.0	47.8	48.2	48.4	50.1	48.7	46.5	49.5		
			Temp Rise-2nd stage °F	--	--	--	--	--	--	--	--	--	--		
		Mid-L	CFM	818	819	825	800	813	803	831	838	791	802		
			Temp Rise-1st stage °F	52.4	52.4	52.1	53.8	53.1	53.8	52.1	51.8	54.9	54.2		
			Temp Rise-2nd stage °F	--	--	--	--	--	--	--	--	--	--		
		Low	CFM	577	628	605	624	615	601	628	573	590	588		
			Temp Rise-1st stage °F	--	--	--	--	--	--	--	--	--	--		
			Temp Rise-2nd stage °F	--	--	--	--	--	--	--	--	--	--		

Table 4 Air Delivery - CFM (Without Filter) * **

* A filter is required for each return air inlet. This table shows the airflow performance without a filter. To determine airflow performance with a filter, if a 3/4 inch (19 mm) washable media filter is used, assume an additional 0.1 in. WC available external static pressure.

** The manufacturer default fan settings are based on model, refer to Table 24.

Furnace size	Return-air inlet	Speed		External static pressure (in. WC)										
				0.1	0.2	0.3	0.4	0.5	0.6	0.7	0.8	0.9	1.0	
100C	Bottom or Sides	H	CFM	1752	1764	1768	1781	1774	1786	1762	1802	1792	1786	
			Temp Rise-1st stage °F											
			Temp Rise-2nd stage °F	47.5	47.3	47.3	47.0	47.3	47.0	47.7	46.8	47.2	47.4	
		Mid-H	CFM	1512	1506	1536	1523	1514	1509	1529	1551	1565	1532	
			Temp Rise-1st stage °F	38.6	38.8	38.1	38.5	38.8	39.0	38.6	38.1	37.9	38.8	
			Temp Rise-2nd stage °F	54.8	55.1	54.1	54.6	55.1	55.3	54.7	54.0	53.6	54.8	
		Mid	CFM	1354	1354	1362	1370	1357	1381	1389	1394	1416	1383	
			Temp Rise-1st stage °F	42.9	43.0	42.8	42.6	43.1	42.4	42.3	42.2	41.7	42.7	
			Temp Rise-2nd stage °F	61.1	61.1	60.8	60.6	61.2	60.3	60.0	59.9	59.0	60.5	
		Mid-L	CFM	1165	1165	1176	1164	1185	1190	1186	1205	1174	1199	
			Temp Rise-1st stage °F	49.7	49.7	49.3	49.9	49.2	49.0	49.2	48.6	49.9	49.0	
			Temp Rise-2nd stage °F	--	--	--	--	--	--	--	--	--	--	
		Low	CFM	994	1025	1018	1024	1032	1026	1035	988	1005	1041	
			Temp Rise-1st stage °F	58.1	56.4	56.9	56.6	56.3	56.7	56.3	59.0	58.1	56.2	
			Temp Rise-2nd stage °F	--	--	--	--	--	--	--	--	--	--	
100D	Bottom or Sides	H	CFM	1926	1926	1931	1943	1936	1941	1960	1974	2015	2043	
			Temp Rise-1st stage °F	--	--	--	--	--	--	--	--	--	--	
			Temp Rise-2nd stage °F	43.2	43.3	43.2	43.1	43.3	43.3	42.9	42.7	42.0	41.6	
		Mid-H	CFM	1746	1752	1749	1748	1749	1763	1771	1776	1794	1791	
			Temp Rise-1st stage °F	--	--	--	--	--	--	--	--	--	--	
			Temp Rise-2nd stage °F	47.5	47.4	47.6	47.7	47.7	47.4	47.3	47.2	46.9	47.0	
		Mid	CFM	1488	1525	1525	1515	1528	1546	1501	1525	1546	1544	
			Temp Rise-1st stage °F	39.0	38.2	38.2	38.6	38.3	37.9	39.1	38.6	38.2	38.3	
			Temp Rise-2nd stage °F	55.6	54.3	54.4	54.8	54.4	53.9	55.5	54.7	54.1	54.2	
		Mid-L	CFM	1348	1374	1341	1383	1381	1385	1408	1404	1400	1401	
			Temp Rise-1st stage °F	43.0	42.3	43.3	42.1	42.2	42.2	41.6	41.8	42.0	42.0	
			Temp Rise-2nd stage °F	61.2	60.2	61.7	59.9	60.1	60.0	59.1	59.3	59.6	59.6	
		Low	CFM	1163	1186	1164	1167	1174	1178	1182	1129	1163	1172	
			Temp Rise-1st stage °F	49.7	48.8	49.8	49.7	49.5	49.4	49.3	51.7	50.3	50.0	
			Temp Rise-2nd stage °F	--	--	--	--	--	--	--	--	--	--	
120D	Bottom or Sides	H	CFM	1926	1933	1915	1923	1916	1929	1971	1941	2036	1998	
			Temp Rise-1st stage °F	--	--	--	--	--	--	--	--	--	--	
			Temp Rise-2nd stage °F	51.8	51.7	52.2	52.1	52.4	52.1	51.1	52.0	49.8	50.7	
		Mid-H	CFM	1721	1747	1716	1749	1760	1768	1778	1783	1747	1788	
			Temp Rise-1st stage °F	--	--	--	--	--	--	--	--	--	--	
			Temp Rise-2nd stage °F	57.8	57.0	58.1	57.1	56.8	56.6	56.4	56.3	57.5	56.4	
		Mid	CFM	1489	1497	1503	1504	1507	1488	1496	1518	1519	1568	
			Temp Rise-1st stage °F	46.7	46.6	46.4	46.5	46.5	47.1	47.0	46.4	46.4	45.1	
			Temp Rise-2nd stage °F	66.5	66.3	66.1	66.1	66.1	67.0	66.7	65.8	65.9	64.0	
		Mid-L	CFM	1384	1360	1365	1384	1382	1383	1379	1401	1421	1414	
			Temp Rise-1st stage °F	50.2	51.1	51.0	50.4	50.6	50.6	50.8	50.1	49.5	49.9	
			Temp Rise-2nd stage °F	--	--	--	--	--	--	--	--	--	--	
		Low	CFM	1165	1175	1162	1158	1158	1184	1186	1204	1201	1185	
			Temp Rise-1st stage °F	59.5	59.0	59.8	60.0	60.1	58.9	58.9	58.1	58.4	59.2	
			Temp Rise-2nd stage °F	--	--	--	--	--	--	--	--	--	--	

Table 5 Air Delivery - CFM (Without Filter) * **

* A filter is required for each return air inlet. This table shows the airflow performance without a filter. To determine airflow performance with a filter, if a 3/4 inch (19 mm) washable media filter is used, assume an additional 0.1 in. WC available external static pressure.

** The manufacturer default fan settings are based on model, refer to Table 24.

3.6 Pr (Incorrect Polarity of L1/L2)

Troubleshooting Chart

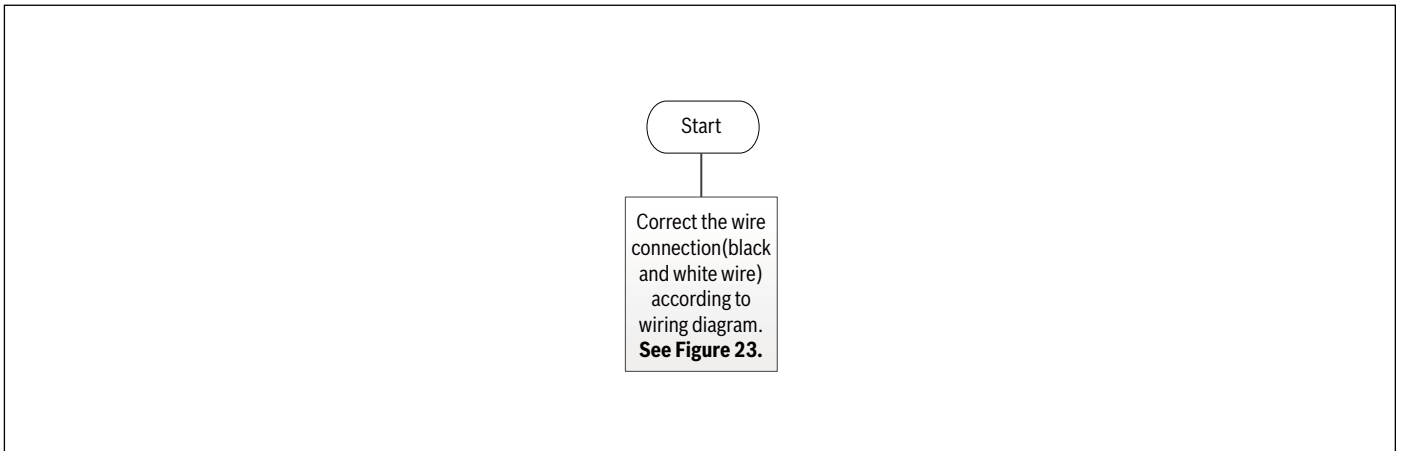

Figures

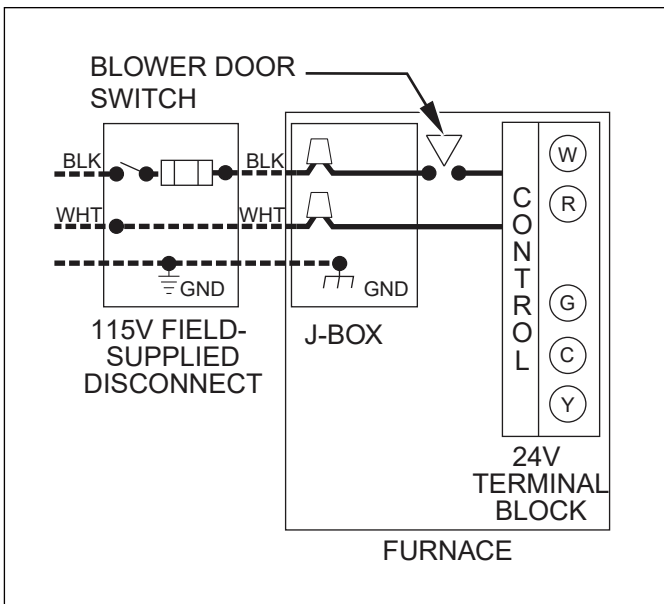

Figure 23

NOTICE:

- ▶ Please refer to the wiring diagram to confirm whether the connection is normal. Please check whether the input power ground wire is correctly and reliably connected to the machine.

3.7 FL (Low Flame)

Troubleshooting Chart

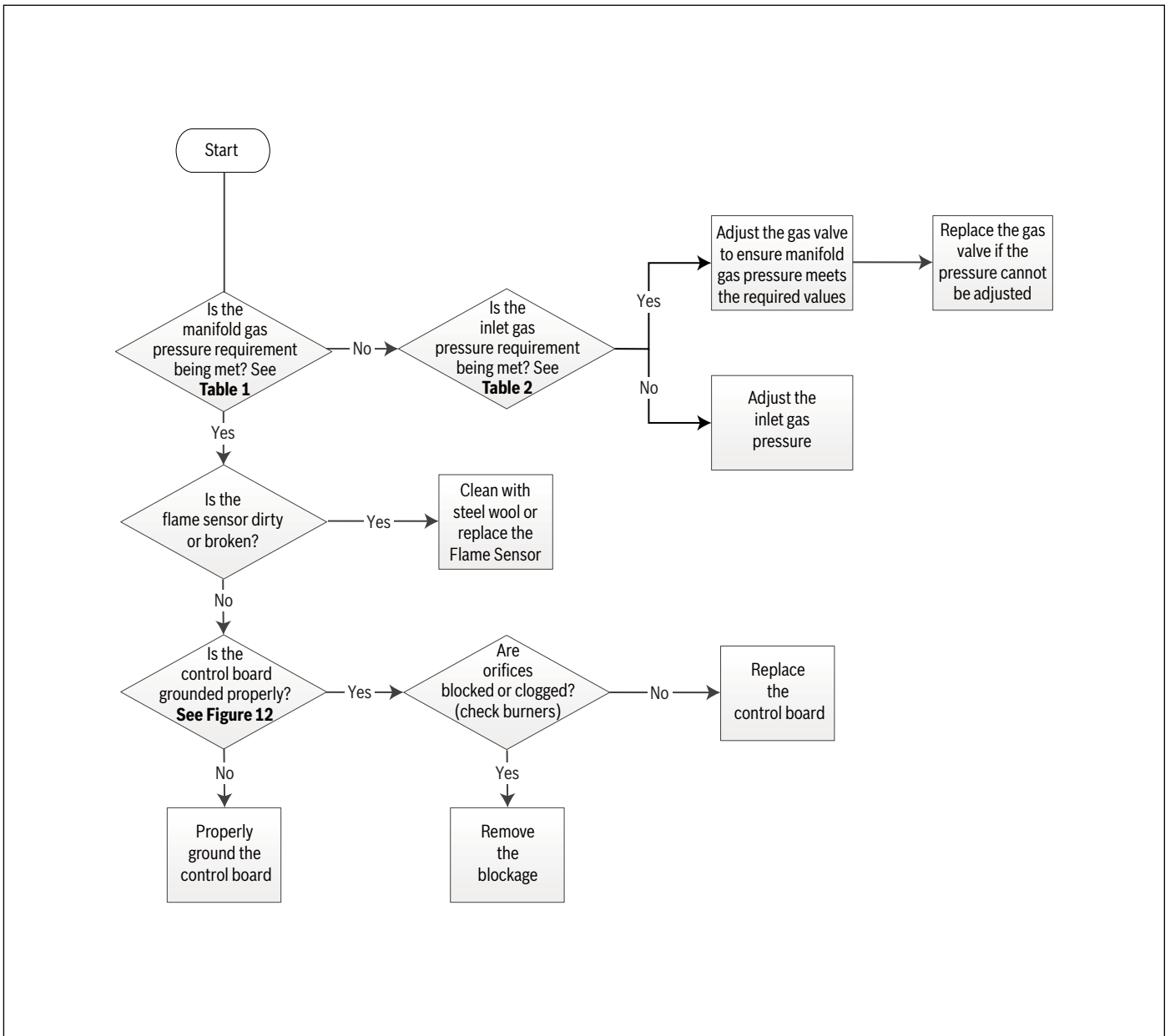

Appendix A - Sequence of Operation

Two Stage Controller Logic

A1. There are two heating modes:

A1.1 Low Fire Heating Mode: Only W1 signal

A1.2 High Fire Heating Mode: Both W1 and W2 signal



If you are using a single stage thermostat, only a W1 signal will be sent. In this scenario, the furnace will upstage from low to high fire via a timing sequence. The time delay is set via the S1-1 & S1-2 dip switches on the control board.

A2. If the furnace fails to ignite, there is a separate logic for the re-ignition sequence.

A1 Heating Modes

A1.1 Low Fire Heating Mode Logic (only W1 signal):

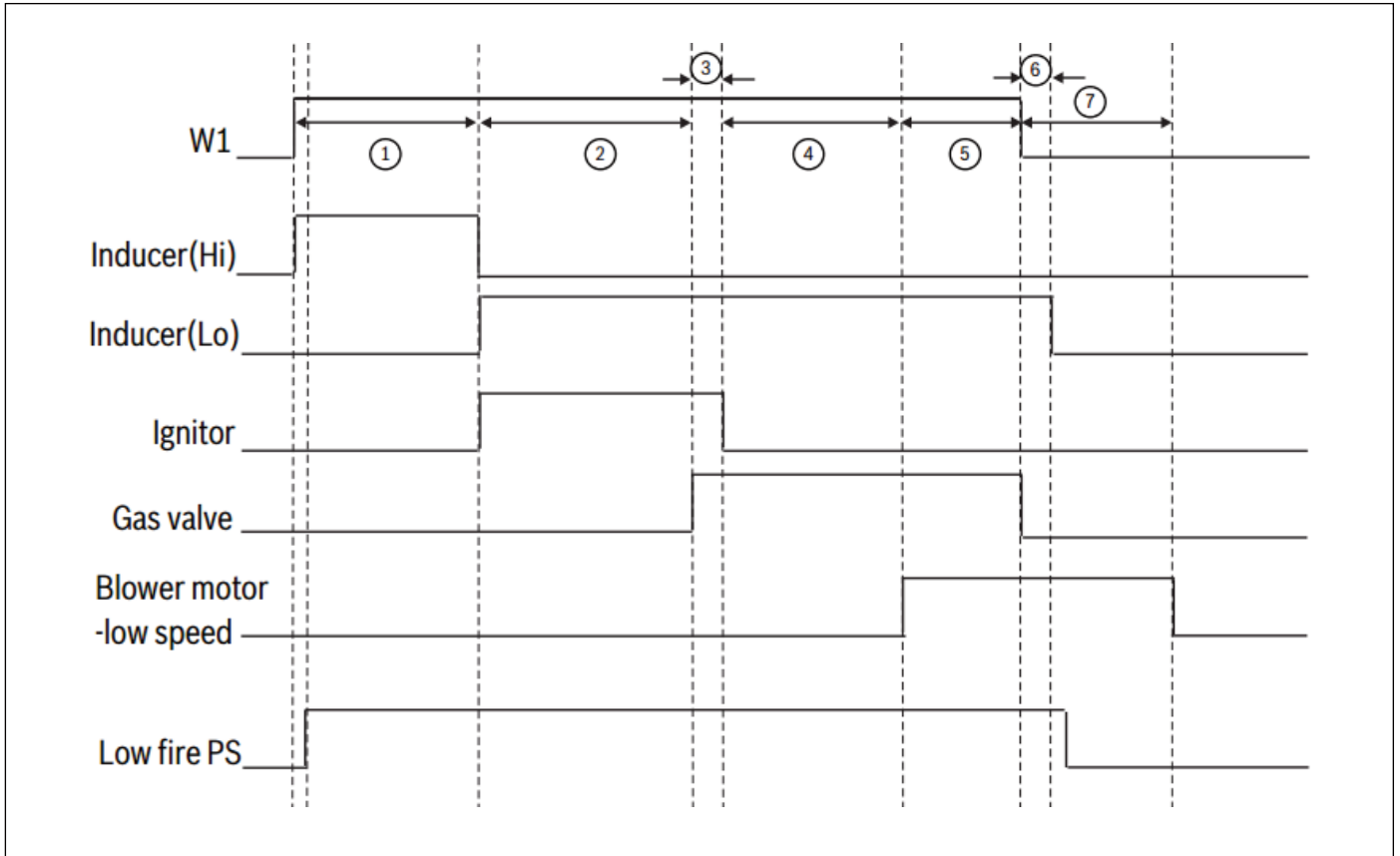

Figure 24

- ① When there is a call for heat (W1), the inducer will start on HIGH speed and the low pressure switch closes. This will last for **15s**.
- ② Inducer will turn to low speed and ignitor will energize. This preheating sequence lasts for **17s**.
- ③ After preheating, gas valve opens and the burners light. The ignitor will turn off after **3s**.
- ④ There is 30s time delay before blower motor starts.
- ⑤ The system is working properly.
- ⑥ When there is no call for heat (no W1 call) and no flame is sensed, post-purge begins. This will last for **15s**.
- ⑦ There is a fan delay to dissipate heat in the system. This time depends on the dip switch S1-3 & S1-4. The default time is **180s**.

A1.2 High Fire Heating Mode Logic (W1+W2 Signal):

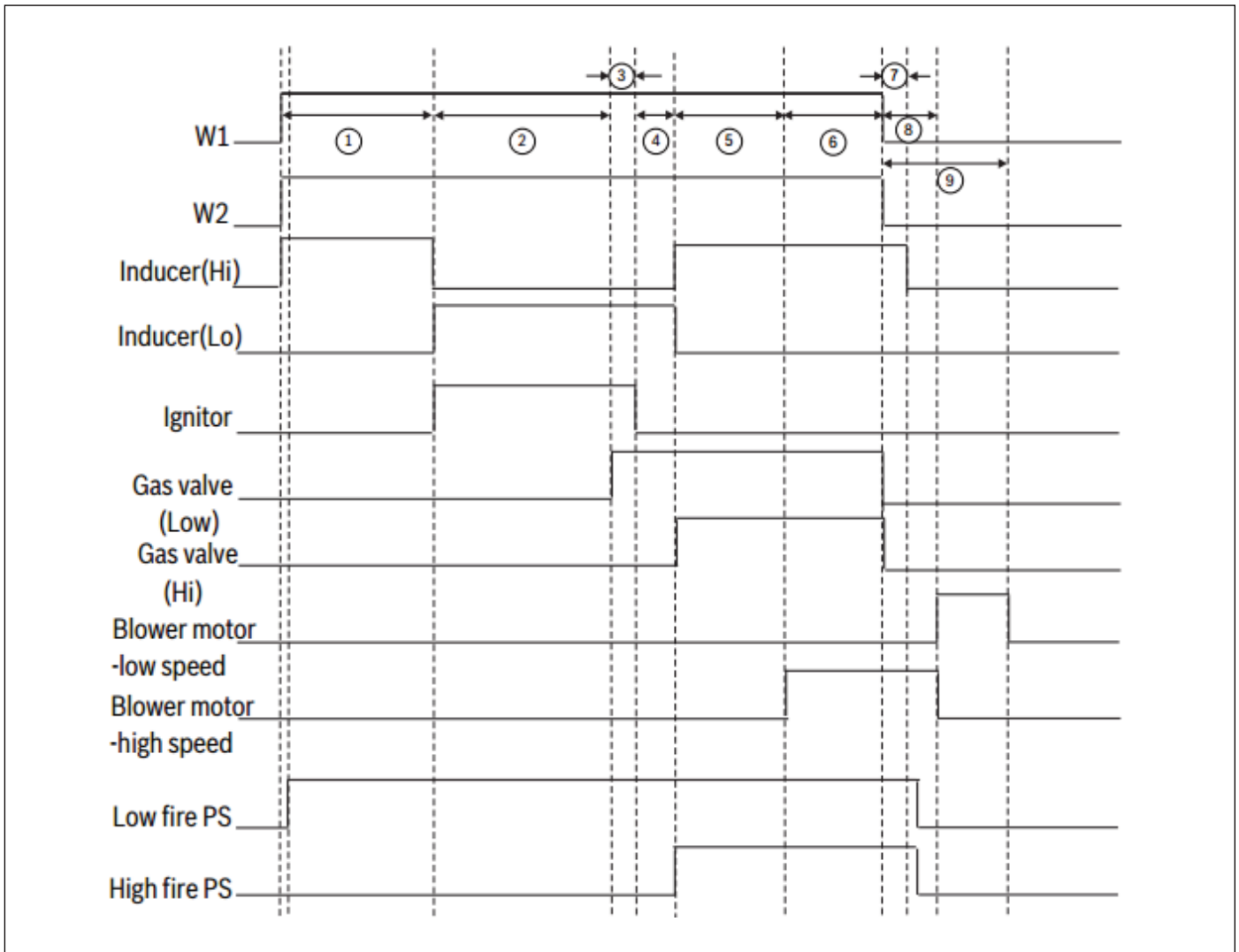

Figure 25

- ① When there is a call for heat (W1), the inducer will start on HIGH speed and the low pressure switch closes. This will last for **15s**.
- ② Inducer will turn to low speed and ignitor will energize. This preheating sequence lasts for **17s**.
- ③ After preheating, gas valve opens and the burners light. The ignitor will turn off after **3s**.
- ④ Before gas valve, inducer, pressure switch turn to high stage, there is a **5s** delay.
- ④ + ⑤ There is a time delay of **30s** before blower motor starts.
- ⑥ The system is working properly in high stage.
- ⑦ When there is no call for heat, there is a time delay before inducer shuts down. This will last for **15s**.
- ⑧ The blower motor will run at high speed for **30s** for fan delay.
- ⑨ There is a fan delay to dissipate heat in the system. This time depends on the dip switch S1-3 & S1-4. The default time is **180s**.

A2 Ignition Failure and Reignition Sequence

If the furnace fails to ignite, there is a separate logic for the re-ignition sequence:

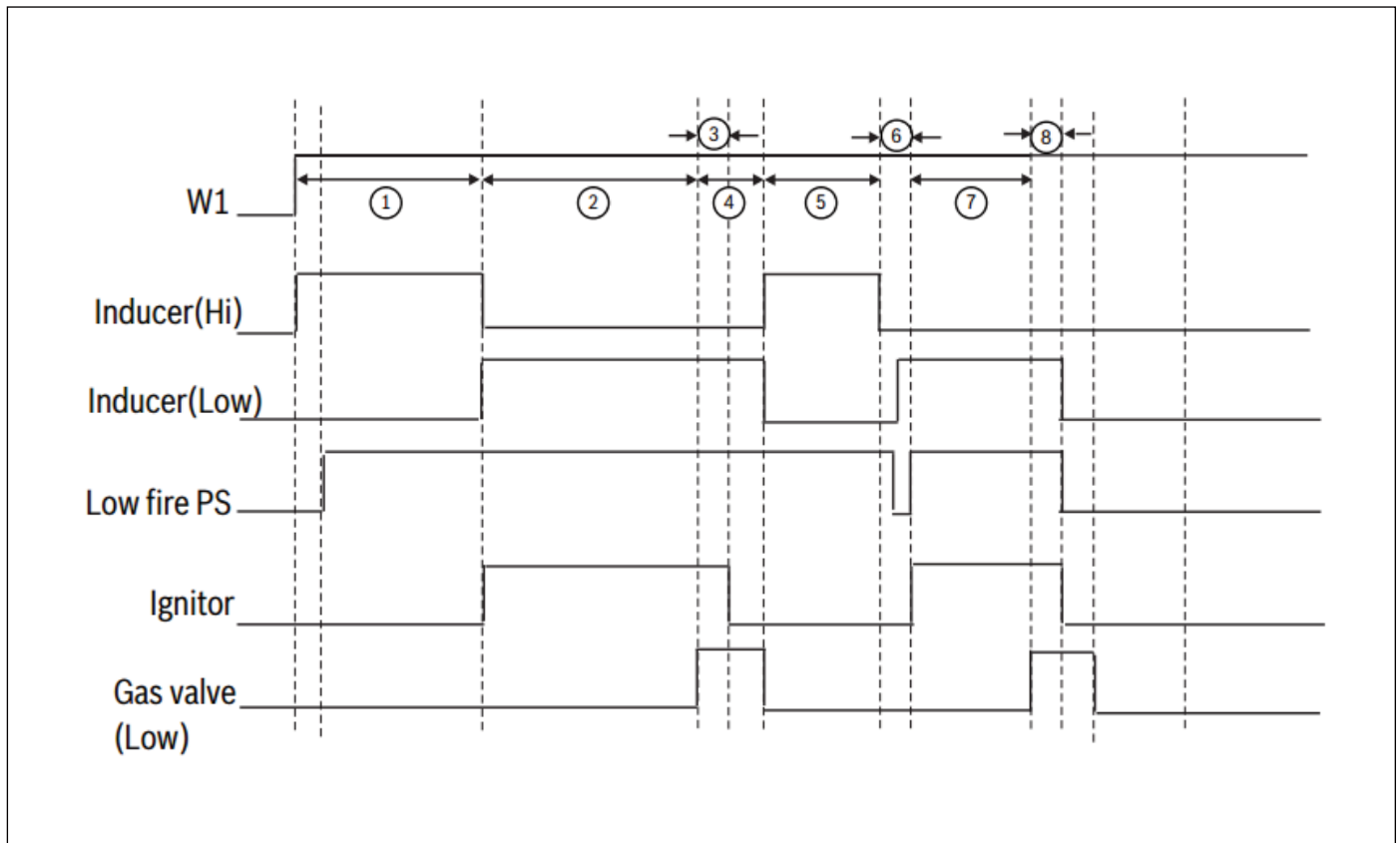

Figure 26

- ① When there is a call for heat (W1), the inducer will start on HIGH speed and the low pressure switch closes. This will last for **15s**.
- ② Inducer will turn to low speed and ignitor will energize. This preheating sequence lasts for **17s**.
- ③ After preheating, gas valve opens and the burners light. The ignitor will turn off after **3s**.
- ④ The gas valve will open for **4s** if there is no flame.
- ⑤ The inducer will run at high speed for **60s**.
- ⑥ Test of low pressure switch.
- ⑦ Preheating occurs for **27s**.
- ⑧ After preheating, gas valve opens. The ignitor will turn off after **3s**. After two failed ignition attempts, system will lock out.

A3 Requirements for refrigerant leakage sensors

W2 DELAY			HEAT OFF DELAY			COOL OFF DELAY		
DIP SW S1-1	DIP SW S1-2	NOMINAL (MINUTES)	DIP SW S2-1	DIP SW S2-2	NOMINAL (SECONDS)	DIP SW S2-3	DIP SW S2-4	NOMINAL (SECONDS)
*OFF	OFF	OFF	*OFF	OFF	90	*OFF	OFF	60
ON	OFF	10	ON	OFF	120	ON	OFF	90
OFF	ON	AUTO	OFF	ON	150	OFF	ON	120
ON	ON	20	ON	ON	180	ON	ON	150

Option Switch Positions

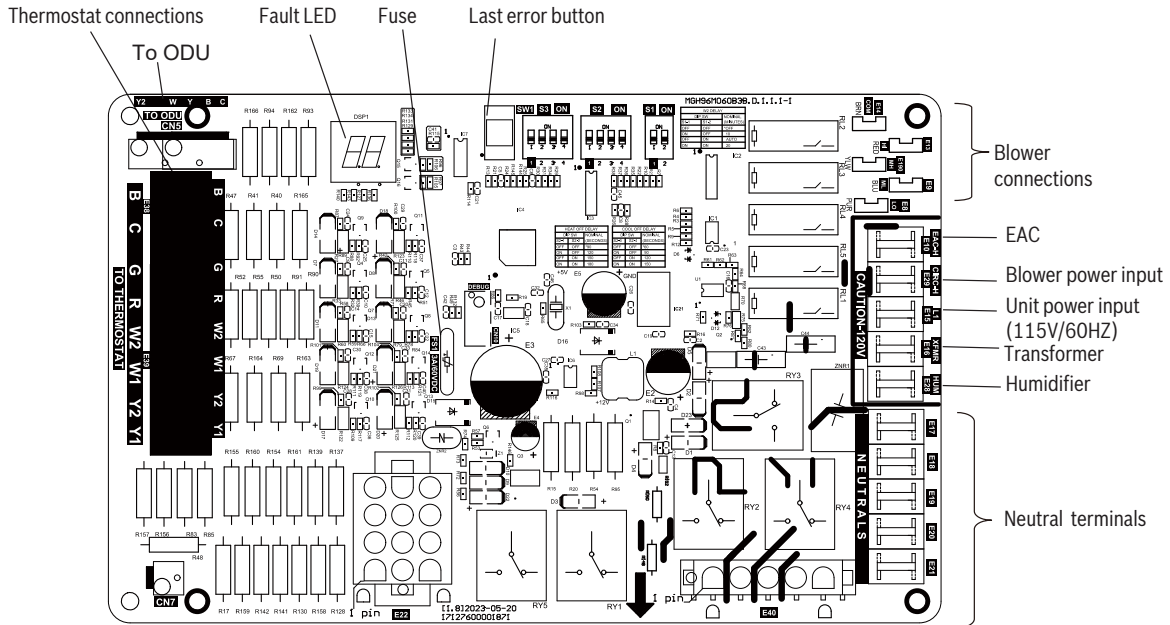

Control Board

SERIES OF PRODUCTS		96% MACHINE TYPE				
SW2-4	OFF	80% GAS FURNACE	DIP SW		TYPE	
	ON	96% GAS FURNACE	SW2-1	SW2-2	SW2-3	
	OFF		OFF	OFF	OFF	* FAN SPEED
	OFF		OFF	OFF	ON	SW1-1 OFF NORMAL SPEED
	OFF		ON	OFF	ON	ON SLOW SPEED
	ON		ON	OFF	OFF	SW1-2 OFF WHITOUT REFRIGERANT SENSOR
	ON		ON	OFF	OFF	ON WHIT REFRIGERANT SENSOR
	ON		ON	OFF	ON	
	ON		ON	ON	ON	

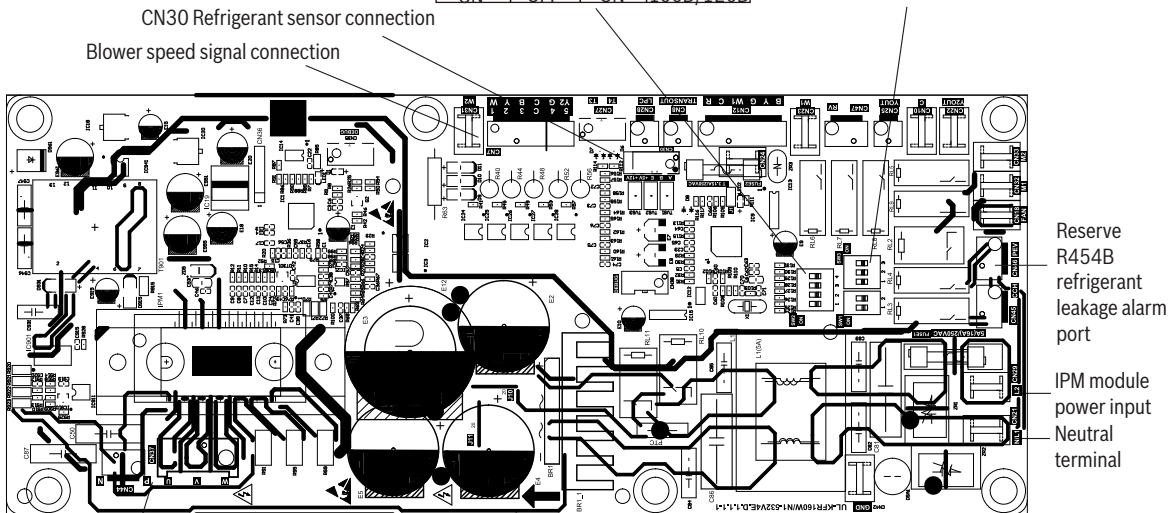

Fan Drive Board

Requirements for refrigerant leakage sensors



WARNING:

- ▶ According to the safety requirements of UL 60335-2-40 on combustible refrigerant A2L, when the gas furnace is used with coil and the new type of combustible refrigerant is used in the coil, the unit must be equipped with the refrigerant gas detection sensor to monitor the refrigerant concentration around the unit in real time to prevent the danger of abnormal refrigerant leakage. Refrigerant gas detection sensors are manufactured under the coil manufacturing label and must be installed by a qualified local gas supplier, distributor or service organization. If the refrigerant gas detection sensor is not installed or is incorrectly installed, it does not meet the requirements of current regulations and cannot effectively warn of an emergency, which may cause personal injury. Therefore, follow the instructions provided in the manual.

Installation of refrigerant gas detection sensor

For the use of our coil unit, please connect the refrigerant gas sensor cable terminal to the CN30 interface, as shown in "Gas Furnace Control Module in Picture 32", and move the drive plate SW1-2 to the "ON" position. Refer to the coil manual for installation locations of refrigerant gas sensors.

Operation indication of refrigerant gas sensor

When the sensor detects a refrigerant leak, the unit will respond according to the following rules.

LED2 Number of green flashes	Fault location	Fault cause	Unit response & handling method
1	The refrigerant sensor communication fails	The communication with the refrigerant sensor fails for 2 minutes or the refrigerant sensor is faulty	The LED2 indicator of the driver board blinks green once, and the Y signal is disconnected to stop cooling. Contact your distributor to check the sensor.
2	Refrigerant concentration exceeds the limit alarm value	The pipe is damaged or the refrigerant leaks	The green light of the drive board LED2 flashes twice, disconnect the Y signal, stop the refrigeration, and the fan in the unit will continue to run until the refrigerant concentration is detected to decrease to a safe value. Maintain ventilation and avoid open flames. Contact the distributor to check the unit.
3	Forget the dip reminder	The sensor is connected and communication is normal, but SW1-2 is in the "OFF" position	LED2 of the driver board blinks green three times Check whether SW1-2 is in the ON position
4	Expiration reminder	The sensor expires or is faulty. Procedure	The LED2 indicator of the driver board blinks green four times to turn off the Y signal and stop cooling. Contact your distributor for a new refrigerant detection sensor.

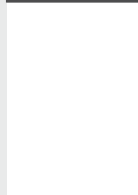

说明书更改说明
此页不做菲林

技术要求：双胶纸100g，黑白印刷，210*297mm