

Midea Installation Manual

Evaporator A-Coil

EVOX  **Horizontal-Vertical Duct**

For 18,000 - 60,000 BTU Systems

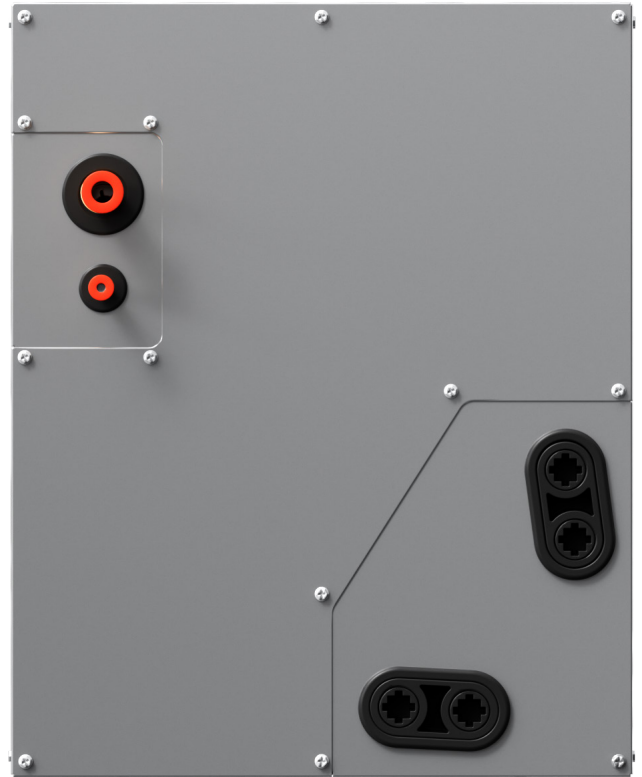
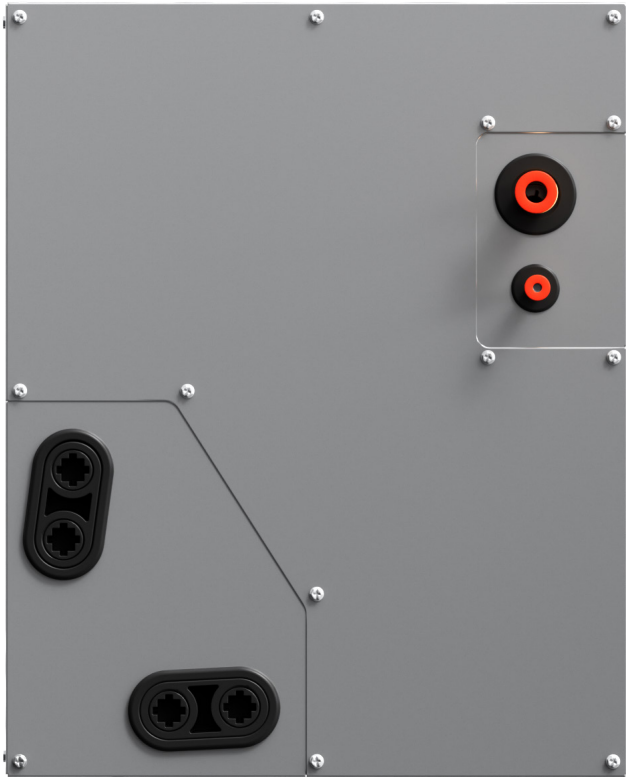

NOTE

You'll find many helpful hints on how to use and maintain your air conditioner properly. Just a little preventive care can save you a great deal of time and money over the life of your air conditioner. These instructions may not cover every possible condition of use, so common sense and attention to safety are required when installing, operating, and maintaining this product.



Units Covered In This Manual

A-COIL MODEL	VOLTAGE, PHASE, Hz
MAAHE-H24B-AA	24, 1, 60
MAAHE-H24B-BA	24, 1, 60
MAAHE-H36B-AA	24, 1, 60
MAAHE-H36B-BA	24, 1, 60
MAAHE-H36B-CA	24, 1, 60
MAAHE-H60B-CA	24, 1, 60
MAAHE-H60B-DA	24, 1, 60



Table of Contents

Safety Considerations	3	Fig. 5-8: Signal Wiring Location.....	22
Table S-1: Allowed Static Pressure Ranges	5	Table 5-2: Inputs.....	23
Table S-2: Approved Matchups.....	5	Table 5-3: Communication	23
Table S-3: Minimum Room Area Requirements.....	6	Table 5-4: Outputs.....	23
Table S-4: R454B Refrigerant Charge Amount And Minimum Airflow.....	6	Fig. 5-9: Wiring Diagram.....	23
Table S-5: Explanation of symbols displayed on the indoor unit or outdoor unit.....	10	Table 5-4: Control Signals To The Furnace.....	24
Installation Accessories	11	Step 6 - Specific Wiring Methods.....	24
Table A-1: Included Accessories.....	11	Table 6-1: Wiring Color Guide	24
Fig. A-1: Unit Parts.....	11	Scenario 1: EVOX Heat Pump and A-Coil 3rd Party 24 V Thermostat	25
Table A-2: Inverter Split Type	11	Fig. 6-1: Scenario 1 Wiring Diagram and Dip Switch Settings.....	25
Product Overview	12	Scenario 2: EVOX Heat Pump, A-Coil, and RS485 Communication	25
Fig. P-1: Component Location.....	12	Fig. 6-2: Scenario 2 Wiring Diagram and Dip Switch Settings.....	25
Fig. P-2: Refrigerant Leak Sensor Location.....	12	Scenario 3: Self-Adapt Mode with 3rd Party Equipment	26
Dimensions	13	Fig. 6-3: Scenario 3 Wiring Diagram and Dip Switch Settings.....	26
Fig. D-1: Unit Dimensions.....	13	24 V Connection Diagrams	26
Table D-1: Dimensions.....	13	Table 6-2: Control Logic.....	26
Fig. D-2: MAAHE-H60B-CA Unit Dimensions.....	13	Fig. 6-4: Never Connect 24 V to S1-S2.....	27
Clearances	14	Fig. 6-5: Wiring for 4H and 2C Thermostat	28
Fig. C-1: Clearance Dimensions.....	14	Fig. 6-6: Wiring for 3H and 1C Thermostat	28
Installation Directions	14	Fig. 6-7: Wiring for 3H and 2C Thermostat	28
Fig. C-2: Airflow Direction Options.....	14	Fig. 6-8: Wiring for 3H and 2C Thermostat	28
Installation Requirements	15	Fig. 6-9: Wiring for 2H and 2C Thermostat	28
Installation	16	Fig. 6-10: Wiring for 2H and 1C Thermostat.....	28
Step 1 - Install the A-Coil.....	16	Fig. 6-11: Wiring for 1H and 1C Thermostat.....	28
Fig. 1-1: Set the Coil on the Furnace.....	16	DIP Switch Definitions.....	29
Fig. 1-2: Downflow Installation with Adapter	16	Fig. 6-12: Dip Switch Layout.....	29
Fig. 1-3: Use an Attachment Plate with screws.....	17	Fig. 6-13: 24 V Thermostat Settings.....	30
Fig. 1-4: Left Installaton Order.....	17	Table 6-2: Function combination table of SW1-1 and SW1-4	30
Step 2 - Drain Piping	17	Table 6-3: Indoor Unit Dial Code	30
Fig. 2-1: Drainpipe Connections	17	Table 6-4: Table A.....	31
Step 3 - Ductwork.....	18	Table 6-5: Wired Remote Control Modes.....	31
Fig. 3-1: Bend Flanges 90°.....	18	Step 7 - Insulate the Piping	31
Fig. 3-2: Flanges After Bending.....	18	Table 7-1: Recommended Insulation Thickness.....	31
Fig. 3-3: Seal All Seams.....	18	Fig. 7-1: Insulate Both Pipes Separately.....	31
Table 3-1: Airflow Performance	18	Test Run	32
Step 4 - Refrigerant Piping Connections	18	Care And Maintenance	32
Table 4-1: Piping Sizes	19	Troubleshooting	32
Fig. 4-1: Wrap Pipes Before Brazing.....	19	Table TS-1: Common Issues.....	33
Step 5 - Wiring Connections	20	Table TS-2: Troubleshooting	34
Fig. 5-1: Wiring Overview	20	Appendix	35
Fig. 5-2: Vertical Coil Installation	21	Table AP-1: 24 V Signal Chart (Cooling & Heating)	35
Fig. 5-3: Horizontal Coil Installation.....	21	Table AP-2: 24 V Signal Chart (Cooling Only).....	36
Fig. 5-4: Wall Mounted.....	21	Indoor Unit Diagnostic Guide.....	37
Fig. 5-5: Open the Cover.....	21	Table AP-3: Indoor Unit Diagnostic Codes	37
Fig. 5-5: Attach Board to Unit or Wall	21		
Fig. 5-6: Cut Outlet for Wires.....	22		
Fig. 5-7: Close the Cover of the Conrol Box.....	22		
Table 5-1: Communication Wiring Sizes.....	22		

Safety Considerations

WARNING

Hazards or unsafe practices that may result in severe personal injury or death.

CAUTION

Hazards or unsafe practices may result in minor personal injury or property damage. Carefully follow the precautions because they are essential to guarantee the safety of the equipment.

DANGER

Identifies the most serious hazards which will result in severe personal injury or death.

NOTE

A property-damage-only hazard, meaning no personal injury is possible.

IMPORTANT

Is used to highlight suggestions which will result in enhanced installation, reliability, or operation.

WARNING

State of California Proposition 65 Warning (US Only)
This product contains chemicals known to the State of California to cause cancer, birth defects, or other reproductive harm.

WARNING

Improper installation, adjustment, alteration, service, maintenance, or use can cause an explosion, fire, electrical shock, or other conditions that may cause death, personal injury, or property damage. Consult a qualified installer, service agency, distributor, or branch for information or assistance. The qualified installer or agency must use factory-authorized kits or accessories when modifying this product. Refer to the individual instructions packaged with kits or accessories when installing.

IMPORTANT

Follow all safety codes. Wear safety glasses, protective clothing, and work gloves. Have a fire extinguisher available. Read these instructions thoroughly and follow all warnings or cautions in the literature and labels attached to the unit. Consult local building codes and the current editions of the National Electrical Code (NEC) NFPA 70.

IMPORTANT

In Canada, refer to the current editions of the Canadian Electrical Code CSA C22.1. Follow the safety information.

WARNING

This appliance is not intended for use by persons (including children) with reduced physical, sensory or mental

capabilities, or lack of experience and knowledge, unless they have been given supervision or instruction concerning use of the appliance by a person responsible for their safety. Children should be supervised to ensure that they do not play with the appliance.

WARNING

WARNINGS FOR PRODUCT USE

- Turn off the air conditioner and disconnect the power before cleaning, installation, or repair. Failure to do so can cause electric shock.
- If an abnormal situation arises (like a burning smell), immediately turn off the unit and disconnect the power. Call your dealer for instructions to avoid electric shock, fire, or injury.
- Do not insert fingers, rods, or other objects into the air inlet or outlet. This may cause injury, since the fan may rotate at high speeds.
- Do not use flammable sprays such as hair spray, lacquer, or paint near the unit. This may cause fire or combustion.
- Do not operate the air conditioner in places near or around combustible gases. Emitted gas may collect around the unit and cause an explosion.
- Do not operate your air conditioner in a wet room such as a bathroom or laundry room. Too much exposure to water can cause electrical components to short circuit.
- Do not expose your body directly to cool air for a prolonged time.
- Do not allow children to play with the air conditioner. Children must be always supervised around the unit.
- If the air conditioner is used together with burners or other heating devices, thoroughly ventilate the room to avoid oxygen deficiency.
- In certain functional environments, such as kitchens, server rooms, etc., the use of specially designed air-conditioning units is highly recommended.

WARNING

WARNINGS FOR PRODUCT INSTALLATION

- Turn off the air conditioner and disconnect the power before performing any installation or repairs. Failure to do so can cause electric shock.
- Installation must be performed by an authorized dealer or specialist according to the installation instructions. Improper installation can cause water damage, electrical hazards, or fire. Contact an authorized service technician for repair or maintenance.
- This appliance shall be installed following national wiring regulations.
- Only use the included accessories, parts, and specified parts for installation.
- Using non-standard parts can cause water leakage, electrical shock, and fire, and can cause the unit to fail.
- Install the unit in a firm location that can support the unit's weight. If the chosen location cannot support the unit's weight, or the installation is not done properly, the unit may drop and cause serious injury and damage.
- Install drainage piping according to the instructions

in this manual. Improper drainage may cause water damage to your home and property.

- For units that have an auxiliary electric heater, do not install the unit within 1 meter (3 ft.) of any combustible materials.
- For the units that have a wireless network function, USB device access, replacement, and maintenance operations must be carried out by professional staff.
- **Do not** install the unit in a location that may be exposed to combustible gas leaks. If combustible gas accumulates around the unit, it may cause fire.
- **Do not** turn on the power until all work has been completed.
- When moving or relocating the air conditioner, consult experienced service technicians for disconnection and reinstallation of the unit.
- How to install the appliance to its support, please read the information for details in the "indoor unit installation" and "outdoor unit installation" sections.

TAKE NOTE OF FUSE SPECIFICATIONS

The air conditioner's circuit board (PCB) is designed with a fuse to provide overcurrent protection. The specifications of the fuse are printed on the circuit board, for example, T3.15 AL/250 VAC, T5 AL/250 VAC, T3.15 A/250 VAC, T5 A/250 VAC, T20 A/250 VAC, T30 A/250 VAC, etc.

NOTE

Only the blast-proof ceramic fuse can be used.

⚠ WARNING

ELECTRICAL WARNINGS

- The power supply of the Mini Interface must meet the requirements of safety isolation.
- Before obtaining access to terminals, all supply circuits must be disconnected.
- Risk of electric shock. Can cause injury or death. Disconnect all remote electric power supplies before servicing.
- The electronic control board only provides control signals and does not drive high-power loads. The external load power cannot be less than 15W.
- Only use the specified wire. If the wire is damaged, it must be replaced by the manufacturer, its service agent, or similarly qualified persons to avoid a hazard.
- The product must be properly grounded at the time of installation, or electric shock may occur.
- For all electrical work, follow all local and national wiring standards, regulations, and the Installation Manual. Connect cables tightly and clamp them securely to prevent external forces from damaging the terminal. Improper electrical connections can overheat, cause fire, and may also cause shock. All electrical connections must be made according to the Electrical Connection Diagram located on the panels of the indoor and outdoor units.
- All wiring must be properly arranged to ensure that the control board cover can close properly. If the control board cover is not closed properly, it can lead to corrosion and cause the connection points on the



- terminal to heat up, catch fire, or cause electric shock.
- External disconnect shall be incorporated in installed wiring as per national and local codes.
- **Do not** share the electrical outlet with other appliances. Improper or insufficient
- Power supply can cause fire or electric shock.
- If connecting power to fixed wiring, an all-pole disconnection device must be incorporated into the fixed wiring following the wiring rules.

⚠ WARNING

CLEANING AND MAINTENANCE WARNINGS

- Turn off the device and disconnect the power before cleaning. Failure to do so can cause electric shock.
- **Do not** clean the air conditioner with excessive amounts of water.
- **Do not** clean the air conditioner with combustible cleaning agents. Combustible cleaning agents can cause fire or deformation.

⚠ CAUTION

- Turn off the air conditioner and disconnect the power if you are not going to use it for a long time.
- Turn off and unplug the unit during storms.
- Make sure that water condensation can drain unhindered from the unit.
- **Do not** operate the air conditioner with wet hands. This may cause electric shock.
- **Do not** use the device for any other purpose than its intended use.
- **Do not** climb onto or place objects on top of the outdoor unit.
- **Do not** allow the air conditioner to operate for long periods with doors or windows open, or if the humidity is very high.

⚠ WARNING

USING FLAMMABLE REFRIGERANT

1. Installation (Space)
 - That the installation of pipe work shall be kept to a minimum.
 - That pipe work shall be protected from physical damage.
 - Where refrigerant pipes shall comply with national gas regulations.
 - That mechanical connections shall be accessible for maintenance purposes.
 - In cases that require mechanical ventilation, ventilation openings shall be kept clear of obstruction.
 - When disposing of the used product, it must be based on national regulations, and properly processed.
2. Service
 - Any person who is involved with working on or breaking into a refrigerant circuit should hold a currently valid certificate from an industry-accredited assessment authority, which authorizes their competence to handle refrigerants safely following an industry-recognized assessment specification.

3. Maintenance and repair requiring the assistance of other skilled personnel shall be carried out under the supervision of a person competent in the use of flammable refrigerants.
4. Do not use means to accelerate the defrosting process or to clean, other than those recommended by the manufacturer.
5. The appliance shall be stored in a room without continuously operating ignition sources (for example: open flames, an operating gas appliance, or an operating electric heater).
6. Be careful that foreign matter(oil, water,etc) does not enter the piping. Also, when storing the piping, securely seal the opening by pinching, taping, etc.
7. Do not pierce or burn.
8. Be aware that refrigerants may not contain an odor.
9. All working procedures that affect safety means shall only be carried out by competent technicians.
10. Appliance shall be stored in a well-ventilated area where the room size corresponds to the room area as specified for operation.
11. The appliance shall be stored to prevent mechanical damage from occurring.
12. Joints shall be tested with detection equipment with a capability of 0.2 oz./year of refrigerant or better, with the equipment in standstill and under operation or pressure of at least these standstill or operation conditions after installation. Detachable joints shall NOT be used in the indoor side of the unit (brazed, welded joints could be used).
13. The refrigerant leakage sensor should be protected to prevent tampering or unauthorized resetting of the pre-set value. To be effective, the refrigerant leakage sensor must be electrically powered at all times after installation, other than when servicing. If the refrigerant sensor detects a refrigerant leak, the indoor unit will display an error code and emit a buzzing sound, the fan will be turned on to the maximum, and the compressor or gas furnace heat source will stop running. You should immediately leave the leak area and notify a professional for handling. the indoor unit will display the error code "FHCC". The refrigerant sensor cannot be repaired and can only be replaced by the manufacturer. The service life of the refrigerant sensor is 15 years, and it should be replaced after the service life.

NOTE

About Refrigerant

- A certified technician must perform product uninstallation and recycling.
- Proper record-keeping of all checks is strongly recommended when the unit is checked for leaks.

The allowed static pressure range of the air conditioner on site is 0-0.80 in. wc. (0-200 Pa). The data below represents the static pressures at the full required air flow used for AHRI testing.

Table S-1: Allowed Static Pressure Ranges

Model	18-24K	30-36K	40-60K
Pressure	0.5 in. wc. (125Pa)	0.5 in.wc. (125Pa)	0.5 in.wc. (125Pa)

For R454B refrigerant charge amount and minimum room area:

The machine you purchased may be one of the types in the table below. The indoor and outdoor units are designed to be used together, and the indoor unit is connected via an air duct system to one or more rooms. Please check the machine you purchased. The height of the room cannot be less than 7.3 ft./2.2 m, and the minimum room area for operating or storage should be as specified in the following table:

Table S-2: Approved Matchups

Product Type	System Size	Indoor Unit	Outdoor Unit
Regular A-coil	18K	MAAHE-H24B-AA	MO1BE-H18B-2A
		MAAHE-H24B-BA	MO1BE-H18B-2A
	24K	MAAHE-H24B-AA	MO1BE-H24B-2A
		MAAHE-H24B-BA	MO1BE-H24B-2A
	30K	MAAHE-H36B-AA	MO1BE-H30B-2A
		MAAHE-H36B-BA	MO1BE-H30B-2A
		MAAHE-H36B-CA	MO1BE-H30B-2A
	36K	MAAHE-H36B-AA	MO1BE-H36B-2A
		MAAHE-H36B-BA	MO1BE-H36B-2A
		MAAHE-H36B-CA	MO1BE-H36B-2A
	48K	MAAHE-H60B-CA	MO1BE-H48B-2A
		MAAHE-H60B-DA	MO1BE-H48B-2A
60K	MAAHE-H60B-CA	MO1BE-H60B-2A	
	MAAHE-H60B-DA	MO1BE-H60B-2A	
Extreme Heat A-coil	18K	MAAHE-H24B-AA	MO1HE-H18B-2A
		MAAHE-H24B-BA	MO1HE-H18B-2A
	24K	MAAHE-H24B-AA	MO1HE-H24B-2A
		MAAHE-H24B-BA	MO1HE-H24B-2A
	30K	MAAHE-H36B-AA	MO1HE-H30B-2A
		MAAHE-H36B-BA	MO1HE-H30B-2A
	36K	MAAHE-H36B-AA	MO1SE-H36B-2A
		MAAHE-H36B-BA	MO1SE-H36B-2A
	48K	MAAHE-H60B-CA	MO1HE-H48B-2A
		MAAHE-H60B-DA	MO1HE-H48B-2A
	60K	MAAHE-H60B-CA	MO1HE-H60B-2A
		MAAHE-H60B-DA	MO1HE-H60B-2A

Table S-3: Minimum Room Area Requirements

Mc or MREL [oz./kg]	T _{Amin} [ft. ² /m ²]	Mc or MREL [oz./kg]	T _{Amin} [ft. ² /m ²]	Mc or MREL [oz./kg]	T _{Amin} [ft. ² /m ²]	Mc or MREL [oz./kg]	T _{Amin} [ft. ² /m ²]
<=62.7/1.776	12/1.1	134/3.8	126/11.67	211.6/6.0	198/18.43	289.2/8.2	271/25.18
63.5/1.8	60/5.53	141.1/4	132/12.29	218.7/6.2	205/19.04	296.3/8.4	278/25.8
70.5/2	66/6.14	148.1/4.2	139/12.9	225.8/6.4	212/19.66	303.4/8.6	284/26.41
77.6/2.2	73/6.76	155.2/4.4	145/13.51	232.8/6.6	218/20.27	310.4/8.8	291/27.63
84.6/2.4	79/7.37	162.2/4.6	152/14.13	239.9/6.8	225/20.88	317.5/9.0	298/27.64
91.7/2.6	86/7.99	169.3/4.8	159/14.74	246.9/7.0	231/21.5	324.5/9.2	304/28.26
98.8/2.8	93/8.6	176.4/5	165/15.36	254/7.2	238/22.11	331.6/9.4	311/28.87
105.8/3	99/9.21	183.4/5.2	172/15.97	261/7.4	245/22.73	338.6/9.6	317/29.48
112.9/3.2	106/9.83	190.5/5.4	179/16.58	268.1/7.6	251/23.34	345.7/9.8	324/30.10
119.9/3.4	112/10.44	197.5/5.6	185/17.2	275.1/7.8	258/23.96	352.7/10.0	331/30.71
127/3.6	119/11.06	204.6/5.8	192/17.81	282.2/8.0	264/24.57		
Area formula	<p>T_{Amin} is the required minimum area of the total conditioned space connected by air ducts in ft.²/m²</p> <p>Mc is the actual refrigerant charge in the system in oz/kg</p> <p>MREL is the refrigerant releasable charge in oz./kg</p> <p>h_{inst} is the height of the bottom of the appliance relative to the floor of the room after installation.</p> <p>WARNING: The minimum room area or minimum room area of conditioned space is based on releasable charge and total system refrigerant charge.</p>						

NOTE

If the actual room size does not fit the abovementioned conditions, please refer to the upper-level condition. Ex. we provide suggestions for a room size of 400 sq. ft., if the room size is 450 sq. ft., please refer to the 500 sq. ft. requirement. When the unit detects a refrigerant leak, the minimum airflow of the indoor unit is as indicated in Table S-4:

Table S-4: R454B Refrigerant Charge Amount And Minimum Airflow

Mc (kg)	QH _{min} (m3/h)	Mc (kg)	QH _{min} (m3/h)	Mc (kg)	QH _{min} (m3/h)	Mc (kg)	QH _{min} (m3/h)	Mc (kg)	QH _{min} (m3/h)	Mc (kg)	QH _{min} (m3/h)
1.4	141.892	3	304.054	4.6	466.216	6.2	628.378	7.8	790.541	9.4	952.703
1.6	162.162	3.2	324.324	4.8	486.486	6.4	648.649	8	810.811	9.6	972.973
1.8	182.432	3.4	344.595	5	506.757	6.6	668.919	8.2	831.081	9.8	993.243
2	202.703	3.6	364.865	5.2	527.027	6.8	689.189	8.4	851.351	10	1013.514
2.2	222.973	3.8	385.135	5.4	547.297	7	709.459	8.6	871.622	10.2	1033.784
2.4	243.243	4	405.405	5.6	567.568	7.2	729.730	8.8	891.892	10.4	1054.054
2.6	263.514	4.2	425.676	5.8	587.838	7.4	750	9	912.162	10.6	1074.324
2.8	283.784	4.4	445.946	6	608.108	7.6	770.270	9.2	932.432	10.8	1094.595
Airflow formula	<p>QH_{min} is the required minimum Airflow in m3/h</p> <p>Mc is the actual refrigerant charge in the system in kg</p> <p>WARNING: The minimum Airflow of conditioned space is based on releasable charge and total system refrigerant charge, and cooling full-load airflow not exceeding 400 scfm per specified ton of cooling.</p>										

1. Installation

- Any person who is involved with working on or breaking into a refrigerant circuit should hold a current valid certificate from an industry-accredited assessment authority, which authorizes their competence to handle refrigerants safely in accordance with an industry-recognized assessment specification.
- Maintenance and repair requiring the assistance of other skilled personnel shall be carried out under the supervision of the person competent in the use of flammable refrigerants.
- That the installation of pipe work shall be kept to a minimum.
- That pipe work shall be protected from physical damage.
- Where refrigerant pipes shall comply with national gas regulations.
- That mechanical connections shall be accessible for maintenance purposes.

- Be careful that foreign matter (oil, water, etc.) does not enter the piping. Also, when storing the piping, securely seal the opening by pinching, taping, etc.
- All working procedures that affect safety means shall only be carried out by competent technicians.
- Appliance shall be stored in a well-ventilated area where the room size corresponds to the room area as specified for operation.
- Joints shall be tested with detection equipment with a capability of 5 g/year of refrigerant or better, with the equipment in a standstill and under operation or under pressure of at least these standstill or operation conditions after installation. Detachable joints should NOT be used on the indoor side of the unit (brazed, welded joints could be used).
- In cases that require mechanical ventilation, ventilation openings shall be kept clear of obstruction.

- 2. When a FLAMMABLE REFRIGERANT is used, the requirements for installation space of appliance and/or ventilation requirements are determined according to**
- the mass charge amount (M) used in the appliance,
 - the installation location,
 - the type of ventilation of the location or the appliance.
 - piping material, pipe routing, and installation shall include protection from physical damage in operation and service, and comply with national and local codes and standards, such as ASHRAE 15, IAPMO Uniform Mechanical Code, ICC International Mechanical Code, or CSA B52. All field joints shall be accessible for inspection before being covered or enclosed.
 - that protection devices, piping, and fittings shall be protected as far as possible against adverse environmental effects, for example, the danger of water collecting and freezing in relief pipes or the accumulation of dirt and debris;
 - that piping in refrigeration systems shall be so designed and installed to minimize the likelihood of hydraulic shock damaging the system;
 - that steel pipes and components shall be protected against corrosion with a rustproof coating before applying any insulation;
 - that precautions shall be taken to avoid excessive vibration or pulsation;
 - the minimum floor area of the room shall be mentioned in the form of a table or a single figure without reference to a formula;
 - after completion of field piping for split systems, the field pipework shall be pressure tested with an inert gas and then vacuum tested before refrigerant charging, according to the following requirements:
 - a. The minimum pressure test for the low side of the system shall be the low side design pressure and the minimum pressure test for the high side of the system shall be the high side design pressure, unless the high side of the system can not be isolated from the low side of the system in which case the entire system shall be pressure tested to the low side design pressure.
 - b. During the pressure test, the system shall maintain the pressure for at least 1 h with no decrease of pressure

indicated by the test gauge, with test gauge resolution not exceeding 5% of the test pressure.

- c. During the evacuation test, after achieving a vacuum level specified in the manual or less, the refrigeration system shall be isolated from the vacuum pump and the pressure shall not rise above 1500 microns within 10 min. The vacuum pressure level shall be specified in the manual and shall be the lessor of 500 microns or the value required for compliance with national and local codes and standards, which may vary between residential, commercial, and industrial buildings.
 - field-made refrigerant joints indoors shall be tightness tested according to the following requirements: The test method shall have a sensitivity of 5 grams per year of refrigerant or better under a pressure of at least 0,25 times the maximum allowable pressure. No leak shall be detected.
 - Any service shall be performed only as recommended by the manufacturer.

3 . Qualification of workers

Any maintenance, service, and repair operations must require the qualification of the working personnel. Every working procedure that affects safety means shall only be carried out by competent technicians who joined the training and achieved competence should be documented by a certificate. The training of these procedures is carried out by national training organizations or manufacturers that are accredited to teach the relevant national competency standards that may be set in legislation. All training shall follow the ANNEX HH requirements of UL 60335-2-40 4th Edition.

Examples of such working procedures are:

- breaking into the refrigerating circuit;
- opening of sealed components;
- opening of ventilated enclosures.

Information Servicing

1. Checks to the area

Before beginning work on systems containing flammable refrigerants, safety checks are necessary to ensure that the risk of ignition is minimized. For repair to the refrigerating system, the following precautions shall be complied with before conducting work on the system.

2. Work procedure

Works shall be undertaken under a controlled procedure to minimize the risk of flammable gas or vapor being present while the work is being performed.

3. General work area

All maintenance staff and others working in the local area should be instructed on the nature of the work being carried out. Work in confined spaces shall be avoided.

4. Checking for the presence of refrigerant

The area should be checked with an appropriate refrigerant detector before and during work, to ensure the technician is aware of potentially flammable atmospheres. Ensure that the leak detection equipment being used is suitable for use with flammable refrigerants, i.e. no sparking, adequately sealed or intrinsically safe.

5. Presence of fire extinguisher

If any hot work is to be conducted on the refrigeration

equipment or any associated parts, appropriate fire extinguishing equipment shall be available to hand. Have a dry powder or CO₂ fire extinguisher adjacent to the charging area.

6. No ignition sources

No person carrying out work on a REFRIGERATING SYSTEM which involves exposing any pipe work shall use any sources of ignition in such a manner that it may lead to the risk of a fire or explosion. All possible ignition sources, including cigarette smoking, should be kept sufficiently far away from the site of installation, repair, removal, and disposal, during which refrigerant can be released into the surrounding space. Before work takes place, the area around the equipment is to be surveyed to make sure that there are no flammable hazards or ignition risks. "No Smoking" signs shall be displayed.

7. Ventilated area

Ensure that the area is in the open or that it is adequately ventilated before breaking into the system or conducting any hot work. A degree of ventilation shall continue during the period that the work is carried out. The ventilation should safely disperse any released refrigerant and preferably expel it externally into the atmosphere.

8. Check the refrigeration equipment

Where electrical components are being changed, they shall be fit for the purpose and to the correct specification. At all times the manufacturer's maintenance and service guidelines shall be followed. If in doubt consult the manufacturer's technical department for assistance. The following checks shall be applied to installations using FLAMMABLE REFRIGERANTS:

- the actual refrigerant charge is in accordance with the room size within which the refrigerant-containing parts are installed;
- the ventilation machinery and outlets are operating adequately and are not obstructed;
- if an indirect refrigerating circuit is being used, the secondary circuits shall be checked for the presence of refrigerant;
- marking to the equipment continues to be visible and legible, marking and illegible signs shall be corrected;
- refrigeration pipe or components are installed in a position where they are unlikely to be exposed to any substance that may corrode refrigerant-containing components unless the components are constructed of materials that are inherently resistant to being corroded or are suitably protected against being so corroded.

9. Checks to electrical devices

Repair and maintenance of electrical components shall include initial safety checks and component inspection procedures. If a fault exists that could compromise safety, then no electrical supply shall be connected to the circuit until it is satisfactorily dealt with. If the fault cannot be corrected immediately it is necessary to continue operation, and adequate temporary solution shall be used.

This shall be reported to the owner of the equipment so all parties are advised.

Initial safety checks shall include:

that capacitors are discharged: this shall be done safely to avoid the possibility of sparking;
that no live electrical components and wiring are exposed while charging, recovering, or purging the system;
that there is continuity of earth bonding;
Sealed electrical components shall be replaced if it's damaged; Intrinsically safe components must be replaced if it's damaged.

10. Sealed electrical components shall be replaced if it's damaged.

11. Intrinsically safe components must be replaced if it's damaged

12. Wiring

Check that cabling will not be subject to wear, corrosion, excessive pressure, vibration, sharp edges, or any other adverse environmental effects. The check shall also take into account the effects of aging or continual vibration from sources such as compressors or fans.

13. Detection of flammable refrigerants

Under no circumstances shall potential sources of ignition be used in the search for or detection of refrigerant leaks. A halide torch (or any other detector using a naked flame) shall not be used.

The following leak detection methods are deemed acceptable for refrigerant systems. Electronic leak detectors may be used to detect refrigerant leaks but, in the case of FLAMMABLE REFRIGERANTS, the sensitivity may not be adequate, or may need re-calibration. (Detection equipment shall be calibrated in a refrigerant-free area.) Ensure that the detector is not a potential source of ignition and is suitable for the refrigerant used. Leak detection equipment shall be set at a percentage of the LFL of the refrigerant and shall be calibrated to the refrigerant employed, and the appropriate percentage of gas (25 % maximum) is confirmed. Leak detection fluids are also suitable for use with most refrigerants but the use of detergents containing chlorine shall be avoided as the chlorine may react with the refrigerant and corrode the copper pipe-work.

NOTE

Examples of leak-detection fluids are

- bubble method,
- fluorescent method agents.

If a leak is suspected, all naked flames shall be removed/ extinguished.

If leakage of refrigerant is found which requires brazing, all of the refrigerant shall be recovered from the system, or isolated (using shut-off valves) in a part of the system remote from the leak. See the following instructions for the removal of refrigerant.

14. Removal and evacuation

When breaking into the refrigerant circuit to make repairs - or for any other purpose conventional procedures shall be used. However, for flammable refrigerants best practice must be followed since flammability is a consideration.

The following procedure shall be adhered to:

- safely remove refrigerant following local and national regulations;
- evacuate;
- purge the circuit with inert gas;
- evacuate;
- continuously flush or purge with inert gas when using a flame to open the circuit; and
- open the circuit.

The refrigerant charge shall be recovered into the correct recovery cylinders if venting is not allowed by local and national codes. For appliances containing flammable refrigerants, the system shall be purged with oxygen-free nitrogen to render the appliance safe for flammable refrigerants. This process might need to be repeated several times. Compressed air or oxygen shall not be used for purging refrigerant systems.

For appliances containing flammable refrigerants, refrigerant purging shall be achieved by breaking the vacuum in the system with oxygen-free nitrogen and continuing to fill until the working pressure is achieved, then venting to the atmosphere, and finally pulling down to a vacuum. This process shall be repeated until no refrigerant is within the system. When the final oxygen-free nitrogen charge is used, the system shall be vented down to atmospheric pressure to enable work to take place.

The outlet for the vacuum pump shall not be close to any potential ignition sources, and ventilation shall be available.

15. Charging procedures

In addition to conventional charging procedures, the following requirements shall be followed:

- Works shall be undertaken with appropriate tools only (In case of uncertainty, please consult the manufacturer of the tools for use with flammable refrigerants) Ensure that contamination of different refrigerants does not occur when using charging equipment. Hoses or lines shall be as short as possible to minimize the amount of refrigerant contained in them.
- Ensure that the refrigeration system is earthed before charging the system with refrigerant.
- Label the system when charging is complete (if not already). Extreme care shall be taken not to overfill the refrigeration system.
- Before recharging the system, it shall be pressure tested with oxygen-free nitrogen (OFN). The system shall be leak tested on completion of charging but before commissioning. A follow-up leak test shall be carried out before leaving the site.

16. Decommissioning

Before carrying out this procedure, the technician must be completely familiar with the equipment and all its details. It is recommended good practice that all refrigerants are recovered safely. Before the task is carried out, an oil and refrigerant sample shall be taken in case analysis is required before the re-use of recovered refrigerant. Electrical power must be available before the task commences.

- a. Become familiar with the equipment and its operation.
- b. Isolate system electrically
- c. Before attempting the procedure ensure that:
 - mechanical handling equipment is available, if required, for handling refrigerant cylinders;
 - all personal protective equipment is available and being used correctly;
 - the recovery process is supervised at all times by a competent person;
 - recovery equipment and cylinders conform to the appropriate standards.
- d. Pump down the refrigerant system, if possible.
- e. If a vacuum is not possible, make a manifold so that refrigerant can be removed from various parts of the system.
- f. Make sure that the cylinder is situated on the scales before recovery takes place.
- g. Start the recovery machine and operate following instructions.
- h. Do not overfill cylinders (no more than 80 % volume liquid charge)
- i. Do not exceed the maximum working pressure of the cylinder, even temporarily.
- j. When the cylinders have been filled correctly and the process completed, make sure that the cylinders and the equipment are removed from the site promptly and all isolation valves on the equipment are closed off.
- k. Recovered refrigerant shall not be charged into another refrigeration system unless it has been cleaned and checked.

17. Labelling

Equipment shall be labeled stating that it has been de-commissioned and emptied of refrigerant. The label shall be dated and signed. For appliances containing FLAMMABLE REFRIGERANTS, ensure that there are labels on the equipment stating the equipment contains FLAMMABLE REFRIGERANT.

18. Recovery

When removing refrigerant from a system, either for servicing or decommissioning, it is recommended good practice that all refrigerants are removed safely.

When transferring refrigerant into cylinders, ensure that only appropriate refrigerant recovery cylinders are employed. Ensure that the correct number of cylinders for holding the total system charge is available. All cylinders to be used are designated for the recovered refrigerant and labeled for that refrigerant (i. e. special cylinders for the recovery of refrigerant). Cylinders shall be complete with pressure-relief valves and associated shut-off valves in good working order. Empty recovery cylinders are evacuated and, if possible, cooled before recovery occurs.

The recovery equipment shall be in good working order with a set of instructions concerning the equipment that is at hand and shall be suitable for the recovery of the flammable refrigerant. If in doubt, the manufacturer should be consulted. In addition, a set of calibrated

weighing scales shall be available and in good working order. Hoses shall be complete with leak-free disconnect couplings and in good condition.

The recovered refrigerant shall be processed according to local legislation in the correct recovery cylinder, and the relevant waste transfer note arranged. Do not mix refrigerants in recovery units especially not in cylinders. If compressors or compressor oils are to be removed, ensure that they have been evacuated to an acceptable level to make certain that flammable refrigerant does not remain within the lubricant. The compressor body shall not be heated by an open flame or other ignition sources to accelerate this process. When oil is drained from a system, it shall be carried out safely.

19. Unventilated areas

- An unventilated area where the appliance using FLAMMABLE REFRIGERANTS is installed shall be so constructed that should any refrigerant leak, it will not stagnate to create a fire or explosion hazard.
- If appliances are connected via an air duct system to one or more rooms with A2L REFRIGERANTS are installed in a room with an area less than Amin, that room shall be without continuously operating open flames (e.g. an operating gas appliance) or other POTENTIAL IGNITION SOURCES (e.g. an operating electric heater, hot surfaces). A flame-producing device may be installed in the same space if the device is provided with an effective flame arrest.
- Auxiliary devices that may be a POTENTIAL IGNITION SOURCE shall not be installed in the ductwork. Examples of such POTENTIAL IGNITION SOURCES are hot surfaces with a temperature exceeding 700 °C and electric switching devices.
- Only auxiliary devices (such as certificated heater kit) approved by the appliance manufacturer or declared suitable with the refrigerant shall be installed in connecting ductwork.
- For duct-connected appliances, false ceilings or drop ceilings may be used as a return air plenum if a REFRIGERANT DETECTION SYSTEM is provided in the appliance and any external connections are also provided with a sensor immediately below the return air plenum duct joint.
- REFRIGERANT SENSORS for REFRIGERANT DETECTION SYSTEMS Shall Only be replaced with sensors specified by the appliance manufacturer.
- LEAK DETECTION SYSTEM installed. The unit must be powered except for service.





20. Transportation, marking, and storage for units

- a. **Transport of equipment containing flammable refrigerants** Compliance with the transport regulations
- b. **Marking of equipment using signs** Compliance with local regulations
- c. **Disposal of equipment using flammable refrigerants** Compliance with national regulations
- d. **Storage of equipment/appliances** The storage of equipment should be following the manufacturer's

instructions.

- e. **Storage of packed (unsold) equipment** Storage package protection should be constructed such that mechanical damage to the equipment inside the package will not cause a leak of the refrigerant charge. The maximum number of pieces of equipment permitted to be stored together will be determined by local regulations.

Table S-5: Explanation of symbols displayed on the indoor unit or outdoor unit

	WARNING	This symbol shows that this appliance used a flammable refrigerant. If the refrigerant is leaked and exposed to an external ignition source, there is a risk of fire.
	CAUTION	This symbol shows that the operation manual should be read carefully.
	CAUTION	This symbol shows that service personnel should be handling this equipment referencing the installation manual.
	CAUTION	This symbol shows that information is available such as the operating manual or installation manual.













Caution: Risk of fire/flammable materials

Installation Accessories

The system is shipped with the following accessories. Use all the installation parts and accessories to install the system. Improper installation may result in water leakage, electrical shock, and fire, or cause the equipment to fail. Keep the installation manual in a safe place and do not discard any other accessories until the installation work has been completed.

Table A-1: Included Accessories

QTY.	Part Name	Part Image
1	Manual	
1	A-COIL Mini Interface (Part on top of foam)	
1	Wired control (In a separate package)	
3	M4*25 Screws ¹	
3	M4*16 Screws ¹	
6	Anchors ¹	
1	Room Temp. Sensor (T1) ¹	
1	Room Temp. Sensor (T1) (5m) ¹	
1	Ferrite Clamp ¹	
1	Cable ties ¹	

1) For mounting the control box to the wall.

NOTE

The wired system control functions as an IR receiver for the handheld remote, if the remote is not used it must be retained with the indoor unit to adjust parameters, and for troubleshooting.

INSPECTION UPON UNIT ARRIVAL

As soon as the unit is received, it should be inspected and noted for possible shipping damage during transportation. It is the carrier's responsibility to cover the cost of shipping damage. The manufacturer or distributor will not accept a claim from contractors for any transportation damage.

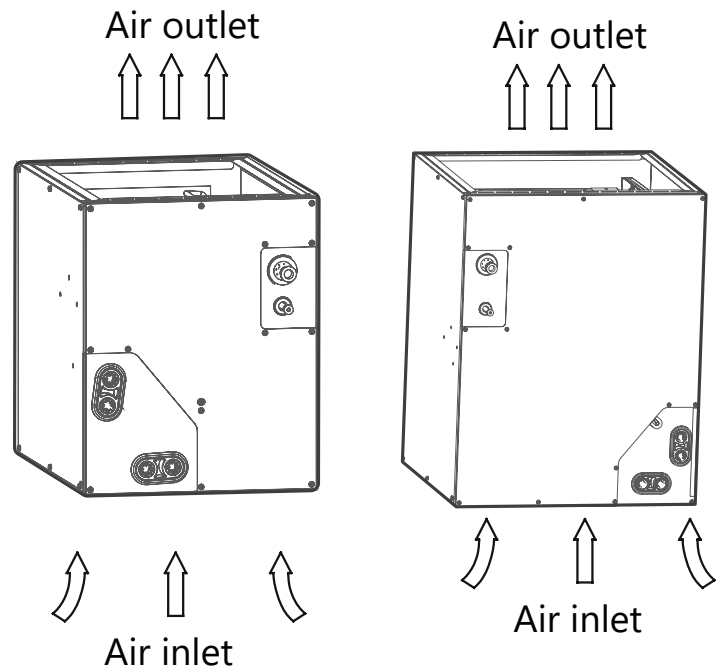

Fig. A-1: Unit Parts

OPERATING CONDITIONS

Use the system under the following temperatures for safe and effective operation. If the air conditioner is used under different conditions, it may malfunction or become less efficient.

Table A-2: Inverter Split Type

Area	COOL Mode	HEAT Mode	DRY Mode
Room Temperature	16°C - 32°C (60°F - 90°F)	0°C - 30°C (32°F - 86°F)	10°C - 32°C (50°F - 90°F)
Recommend Outdoor Temperature	-30°C - 50°C (-22°F - 122°F) (For Extreme Heat Series)	-30°C - 24°C (-22°F - 75°F) (For Extreme Heat Series)	0°C - 50°C (32°F - 122°F)
	-25°C - 50°C (-13°F - 122°F) (For Regular Heat Series)	-25°C - 24°C (-13°F - 75°F) (For Regular Heat Series)	

FOR OUTDOOR UNITS WITH AUXILIARY ELECTRIC HEATER

When the outside temperature is below 0°C (32°F), we strongly recommend keeping the outdoor unit always powered to prevent damage to equipment.

NOTE

Room relative humidity less than 80%. If the air conditioner operates over this figure, the surface of the air conditioner may attract condensation.

When the gas furnace enters heating mode, the air conditioner is in a closed state for a long time

Product Overview

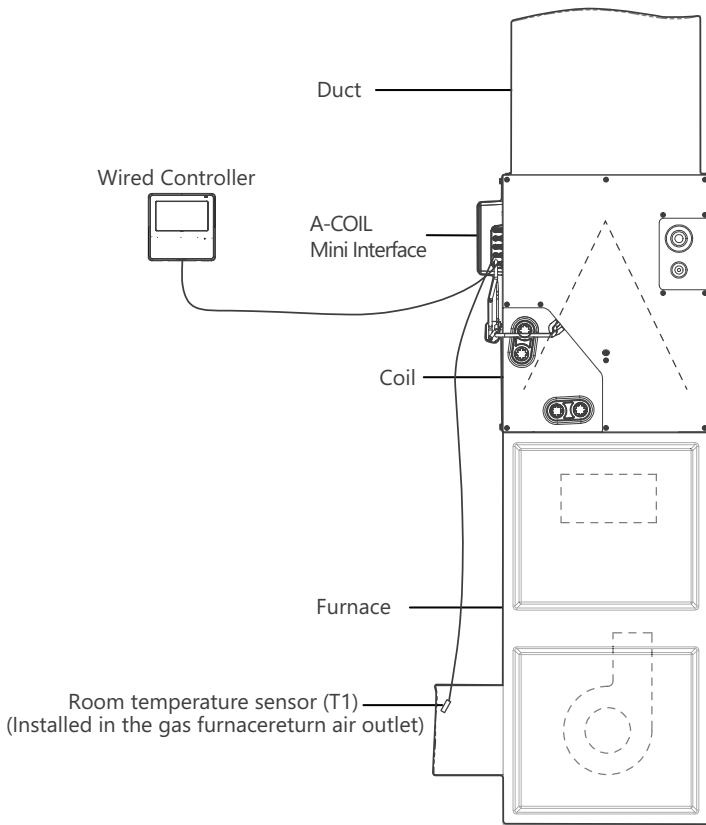
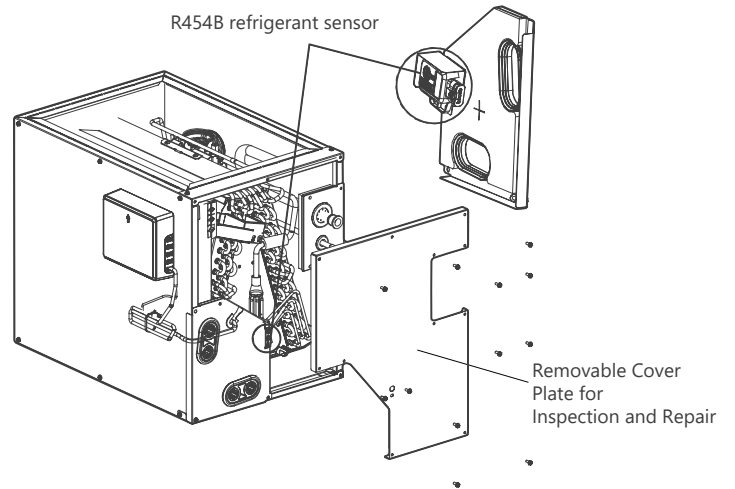

Fig. P-1: Component Location

⚠ WARNING

There must be an airtight seal between the bottom of the A-coil and the return air plenum. Use fiberglass sealing strips, foil duct tape, caulking, or an equivalent sealing method between the plenum and the A-coil cabinet to ensure a tight seal. Return air must not be drawn from a room where this A-coil or any gas-fueled appliance (i.e., water heater), or carbon monoxide-producing device (i.e., wood fireplace) is installed.



MAAHE-H60B-CA

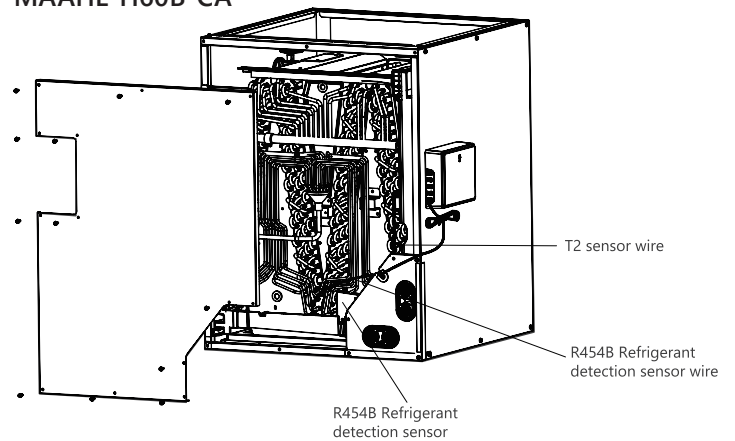

Fig. P-2: Refrigerant Leak Sensor Location

Dimensions

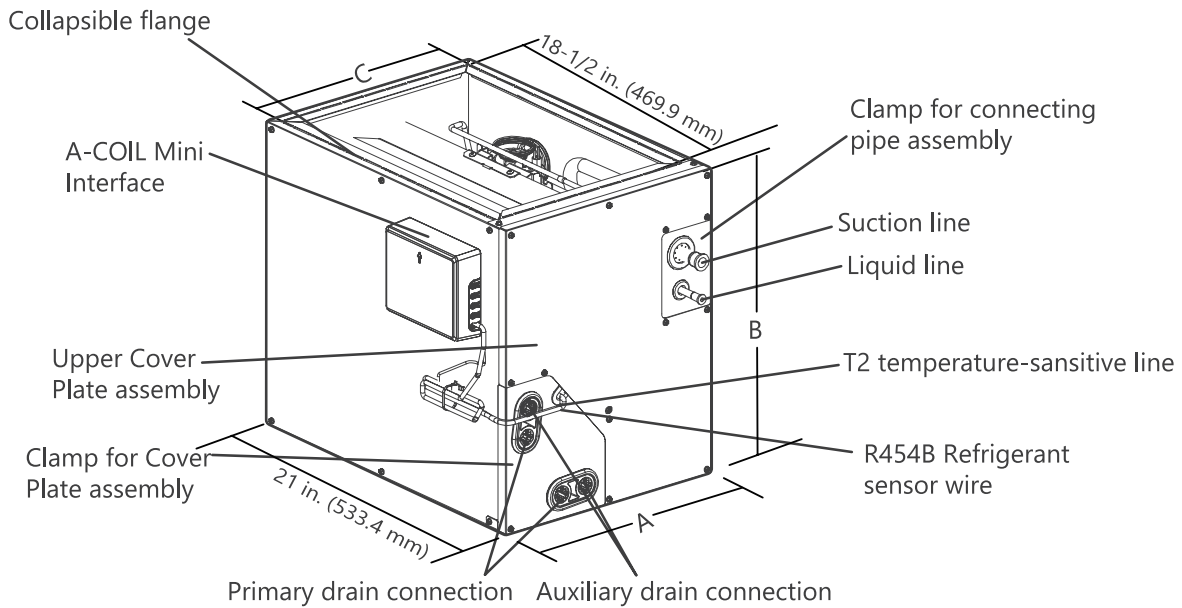

Fig. D-1: Unit Dimensions

Table D-1: Dimensions

Dimensions	24-A		36-A		24-B		36-B		36-C		60-D	
	in.	mm	in.	mm	in.	mm	in.	mm	in.	mm	in.	mm
A	14-1/2	368.3	14-1/2	368.3	17-1/2	444.5	17-1/2	444.5	21	534	24-1/2	622.3
B	18	457	23-9/16	599	18	457	23-1/2	599	24	609	28	711
C	13-1/4	336	13-1/4	336	16-1/4	412	19-3/4	412	19.7	501.7	23-1/4	590.8

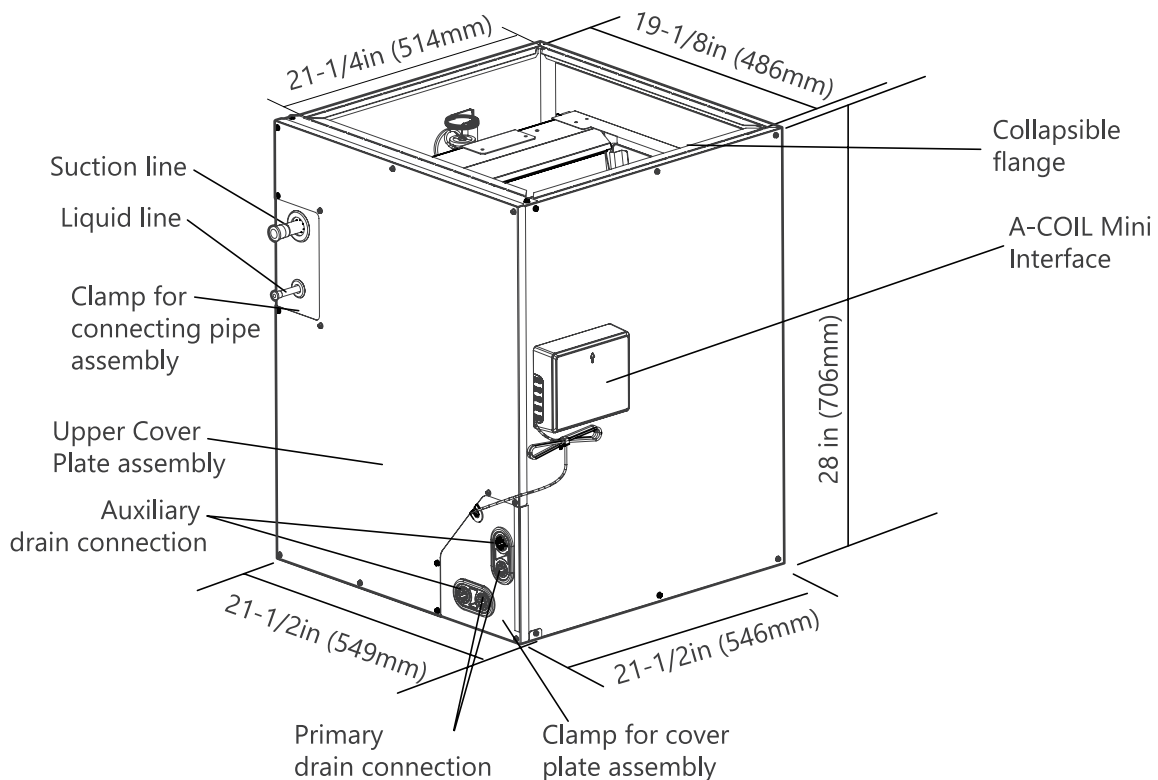

Fig. D-2: MAAHE-H60B-CA Unit Dimensions

Clearances

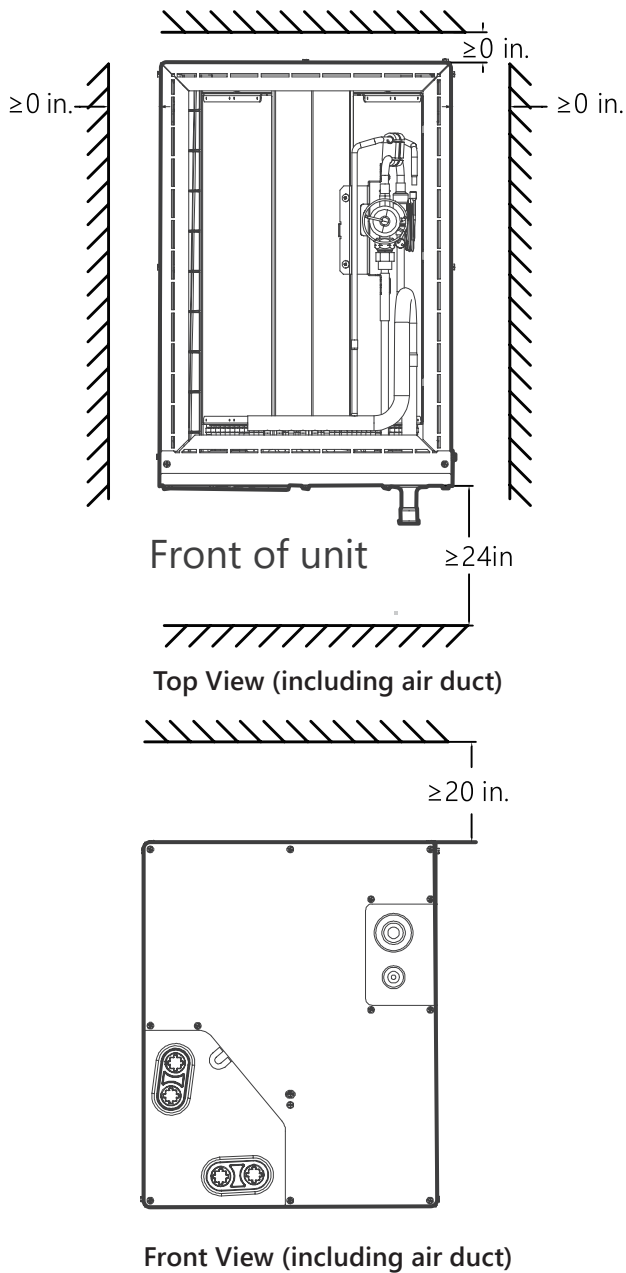

Fig. C-1: Clearance Dimensions

Following clearances should be provided during installation

- Maintenance and service access, including coil cleaning and coil assembly removal
- Refrigerant piping and connections
- Condensate drain line

Ensure the proper installation, Select a solid and level site. Ensure enough space required for installation and maintenance

Installation Directions

Upflow Discharge Downflow Discharge

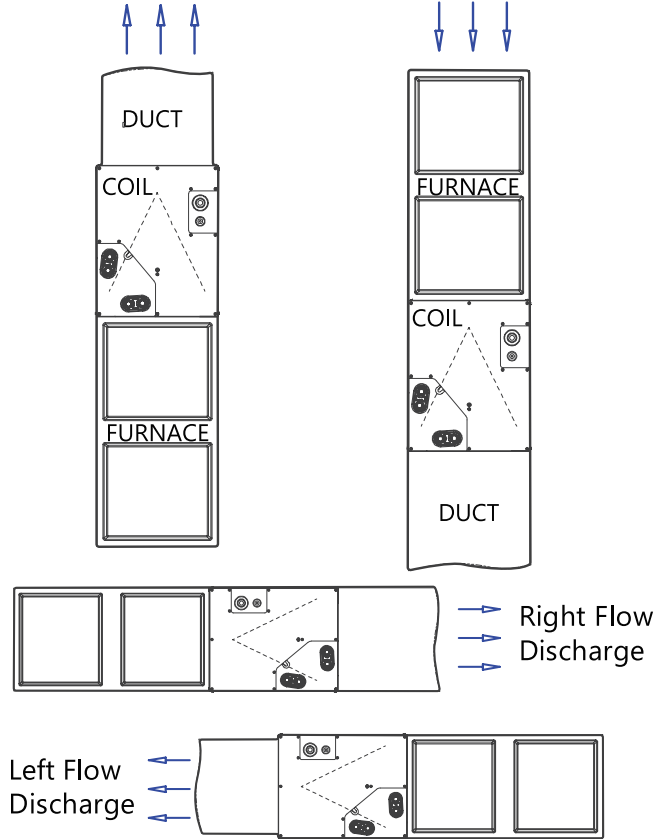

MAAHE-H60B-CA

Upflow Discharge

Downflow Discharge

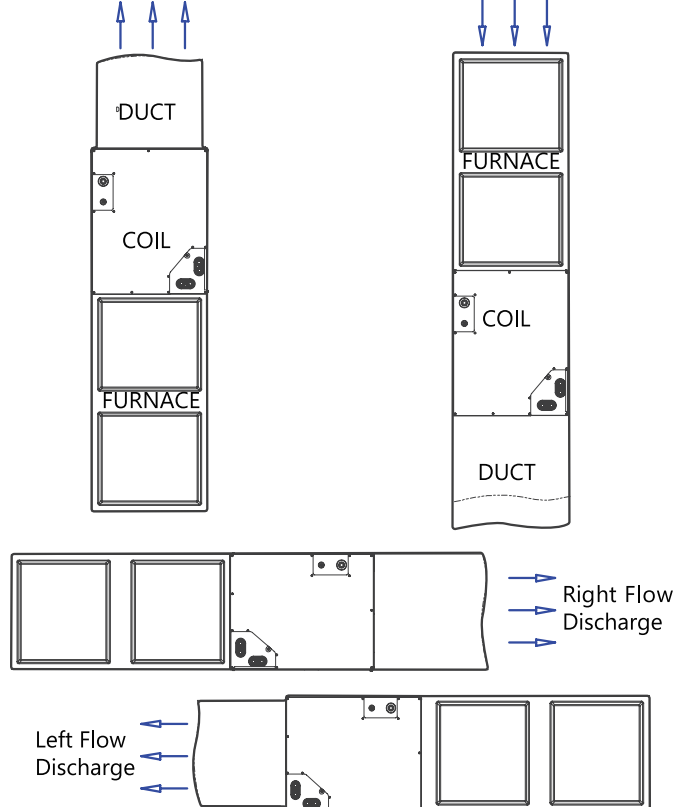

Fig. C-2: Airflow Direction Options

Installation Requirements

⚠ CAUTION

Install the indoor and outdoor units, cables and wires at least 3-1/5 ft. (1 m) from televisions or radios to prevent static or image distortion. Depending on the appliances, a 3-1/5 ft. (1 m) distance may not be sufficient.

The indoor unit must be electrically grounded per national and local electrical code.

⚠ WARNING

DO NOT INSTALL IN THE FOLLOWING LOCATIONS:

-  • DO NOT install the indoor unit in a moist environment. Excessive moisture can corrode the equipment, and electrical components, and cause electrical shorts.
-  • Areas with strong electromagnetic waves.
-  • Coastal areas with high salt content in the air.
-  • Areas with oil drilling or fracking.
-  • Areas that store flammable materials or gas.
-  • Areas where there may be detergent or other corrosive gases in the air, such as bathrooms, or laundry rooms.
-  • Areas where the air inlet and outlet may be obstructed.
-  • The danger of explosion. Keep flammable materials and vapors, such as gasoline, away from the A-coil.

⚠ WARNING

THE UNIT MUST BE INSTALLED IN A LOCATION THAT MEETS THE FOLLOWING REQUIREMENTS:

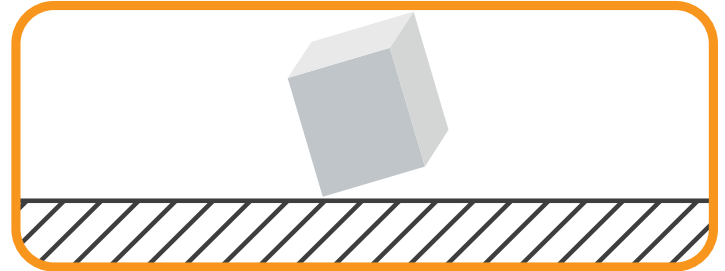

A Stable Position

Securely install the indoor unit on a structure that can support its weight. If the structure is too weak, the unit may fall and cause personal injury, unit and property damage, or death.

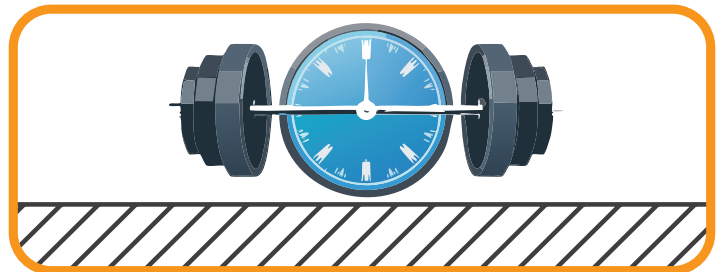

Must Support the Weight of the Indoor Unit

The structure that the equipment is suspended from must support the weight of the indoor unit.



Ample Room

- Enough room for installation and maintenance.
- Enough room for the connecting pipe and drainpipe.

NOTE

Remove all accessories and packing in the air outlet before installation.

- Please apply a sealant around the places where the wires, refrigerant pipes and condensate pipes enter the cabinet.
- Use duct tape or flexible sealant to seal closed any space around the holes where the drain lines exit the cabinet. Warm air must not be allowed to enter through any gaps or holes in the cabinet.

Installation

Step 1 - Install the A-Coil

UPFLOW COIL INSTALLATION

The cased coil is designed to fit furnaces of the same width.

1. Set coil in place on upflow furnace discharge air opening.

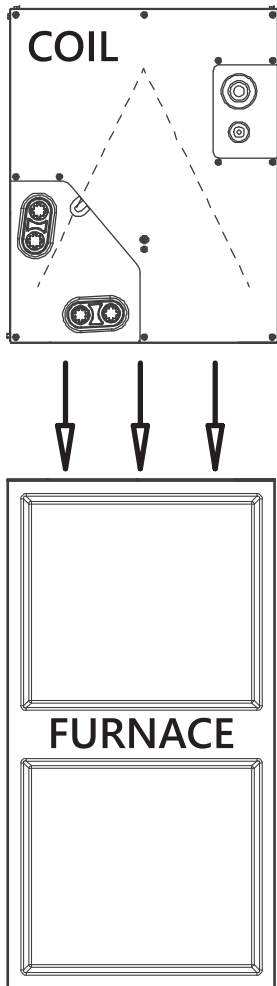

Fig. 1-1: Set the Coil on the Furnace

2. Ensure the coil is level for proper condensate drainage. Do not tip the coil toward the condensate drain. The coil casing need not be fastened or screwed to the furnace.
3. Create a field-fabricated adapter for a wider coil on a narrow furnace.

NOTE

On upflow installations where the indoor coil is placed in an unconditioned space, a 6 in. wide piece of insulation should be applied and wrapped around the outside of the coil casing and supply duct contact point.

NOTE

Consult the furnace installation instructions for any special requirements when installing the coil to the furnace.

DOWNFLOW COIL INSTALLATION

IMPORTANT

If the airflow is high due to ductwork or other causes, and

there is a chance for water to blow off. In that case, it is recommended that a 4 in. minimum field-supplied adapter

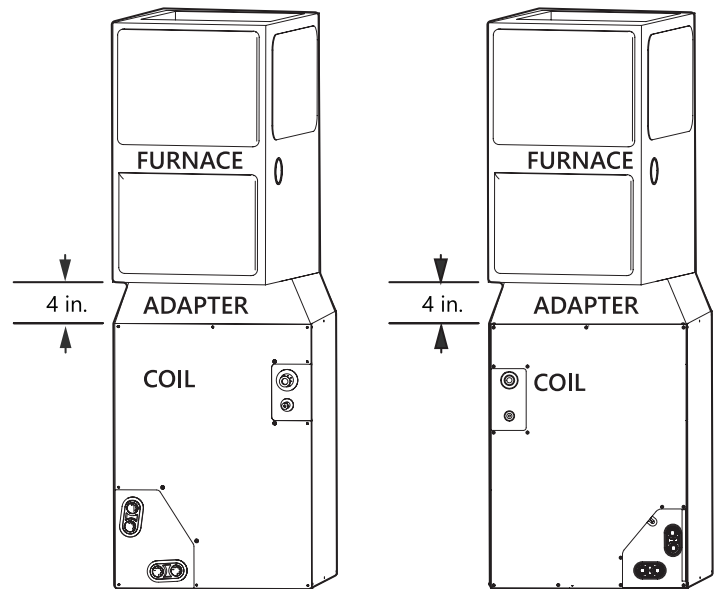

be placed between the coil and the furnace to allow the air to distribute evenly to both coil slabs.

Fig. 1-2: Downflow Installation with Adapter

1. Set the cased coil on the supply duct opening.
2. Place field fabricated 4-in. minimum adapter on coil casing. The adapter should be tapered to fit coil/furnace combination when one of them is larger than the other.
3. Set the furnace on the adapter.

NOTE

In downflow installation with a 4-way multiplies furnace, break off perforated duct flanges on the furnace. See furnace installation instructions.

INSTALLATION OF REFRIGERANT SENSOR

The wire of the refrigerant sensor must be connected to the leak mitigation control kit. For specific operation instructions, please refer to the Wiring Diagrams and Explanatory label of the leak mitigation control kit.

⚠ WARNING

When using a gas furnace for heating, ensure the air outlet temperature does not exceed 200°F. Exceeding this temperature may cause the refrigerant leak sensor to malfunction, leading to a hazardous situation.

HORIZONTAL COIL INSTALLATION

The unit can be installed on a work platform, secured to a roof truss in the attic, suspended from hangers on floor joists in crawl space, or installed on blocks. It is designed to allow airflow in either direction, to mate with horizontal-left or horizontal-right furnace installations.

Ensure the coil cabinet is level side to side and front to back. It is allowable to add up to 1/2 in. additional slope over the length and depth of the coil cabinet in the direction of the drain pan connection.

HORIZONTAL RIGHT INSTALLATION

1. Use field fabricated attachment plates to secure the coil to the furnace.

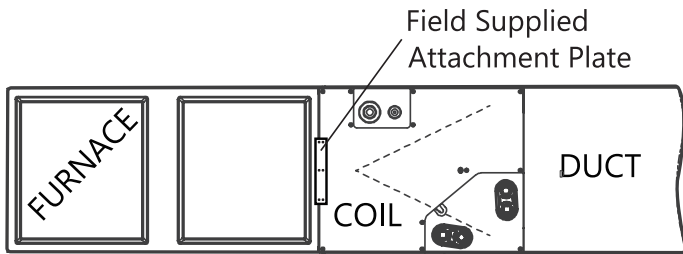

Fig. 1-3: Use an Attachment Plate with screws

2. Use self-tapping screws to mount attachment plates to the coil casing.
3. Connect the furnace snugly against the coil casing.
4. Use self-tapping screws to attach the furnace.
5. Seal the joint between the coil casing and furnace to create an air-tight seal using locally approved materials.
6. If the coil is wider than the furnace, use a 4-in. minimum transition and self-tapping screws to attach the furnace.

HORIZONTAL LEFT INSTALLATION

1. Unbend the 4 tabs at the right side of the casing.

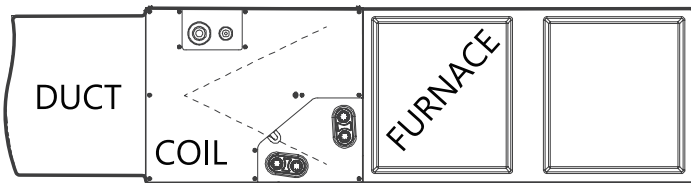

Fig. 1-4: Left Installaton Order

2. Connect the furnace snugly against the coil casing.
3. Use self-tapping screws to attach the furnace.
4. Seal the joint between the coil casing and furnace to create an airtight seal using locally approved materials.
5. If the coil is wider than the furnace, use 4-in. Minimum transition and self-tapping screws to attach the furnace.

Step 2 - Drain Piping

⚠ CAUTION

CONDENSATE DRAIN LINE CONNECTION

Failure to follow this caution may result in property damage. When installing over a finished ceiling and/or living area, install a field-fabricated secondary condensate pan under the entire unit.

The coil is designed to dispose of accumulated water through built-in condensate drain fittings. It is recommended that PVC fittings be used on the condensate pan. Do not over-tighten. Finger tighten plus 1-1/2 turns. Be sure to install the plastic plug in the unused condensate drain fitting. Two 3/4 in. female threaded pipe connections are provided in each coil condensate pan. A trap is not necessary on the condensate line if on the supply air side of the furnace. Consult local codes for additional restrictions or precautions. If local codes require a trap, then the following guidelines are suggested to ensure proper drainage. Install a trap in the condensate line of the coil as close to the coil as possible. Make the trap at least 3 in. (76 mm) deep and no higher than the bottom of the unit condensate drain opening. Pitch condensate line 1 in. (25.4 mm) for every 10 ft. of length to an open drain or sump. Make sure that the outlet of each trap is below its

EVOX A-Coil Evaporator

connection to the condensate pan to prevent condensate from overflowing the drain pan. Prime all traps, test for leaks and insulate traps and lines if located above a living area.

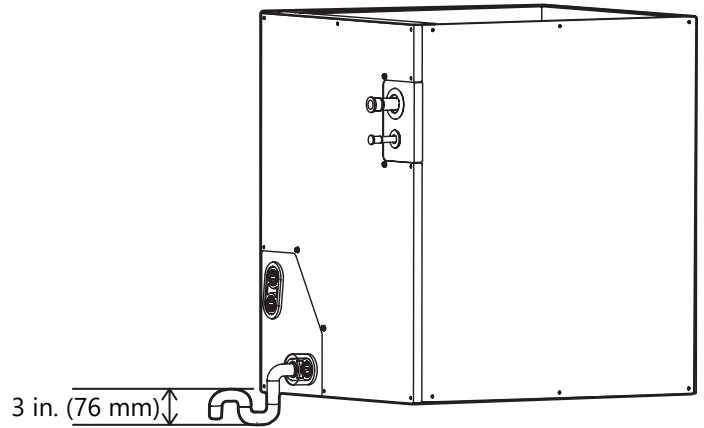

Fig. 2-1: Drainpipe Connections

⚠ WARNING

Failure to follow this warning could result in personal injury or death. Provide a trap with an air gap in the drain line when connecting to the waste (sewer) line.

NOTE

If the unit is located in or above a living space, where damage may result from condensate overflow, a field-supplied, external condensate pan should be installed underneath the entire unit, and a secondary condensate line (with appropriate trap) should be run from the unit into the pan. Any condensate in this external condensate pan should be drained to a noticeable place. As an alternative to using an external condensate pan, some localities may allow the running of a separate 3/4 in. (19 mm) condensate line (with appropriate trap) per local code to a place where the condensate will be noticeable. The owner of the structure must be informed that when condensate flows from a secondary drain or external condensate pan, the unit requires servicing, or water damage will occur. To further protect against water damage, install a float switch to shut the unit off if the water in the secondary pan gets too high.

WASTE LINE CONNECTION

If the condensate line is to be connected to a waste (sewer) line, an open trap must be installed ahead of the waste line to prevent the escape of sewer gases.

Step 3 - Ductwork

FLANGED MOUNTING

1. Use a folding tool and hand seamer to fold up the flange.

Clamp the flange in the middle of the hole and bend it up 90 degrees

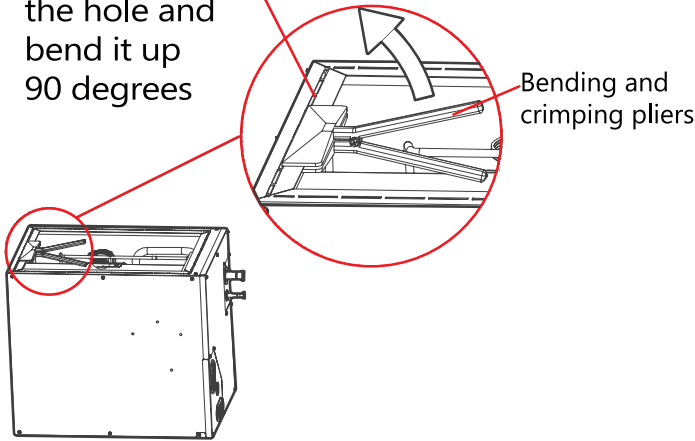

Fig. 3-1: Bend Flanges 90°

2. Fold the flanges on all 4 sides.

Diagram of flange after bending

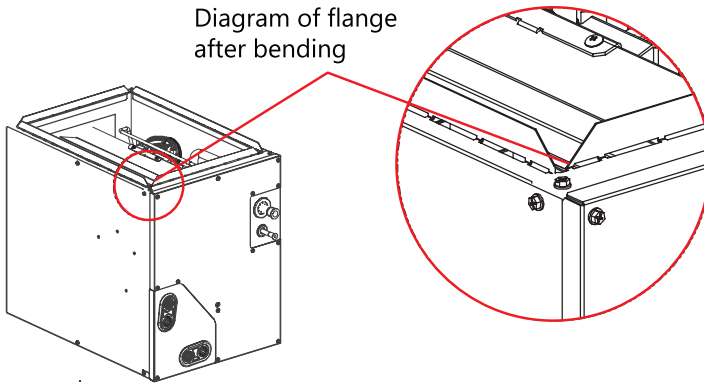

Fig. 3-2: Flanges After Bending

3. Seal all sides with tape and keep warm with a sponge.

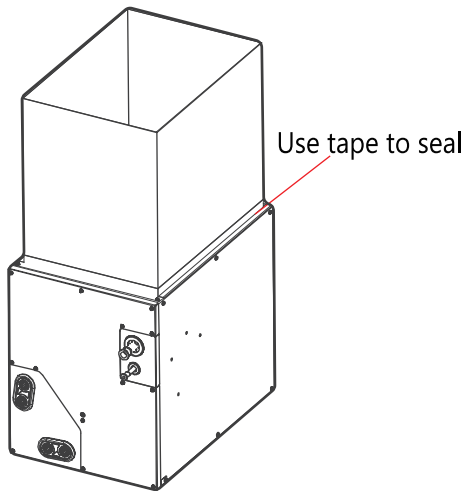

Fig. 3-3: Seal All Seams

Table 3-1: Airflow Performance

Model	Outdoor Unit (ton)	Minimum	Maximum
MAAHE-H24B-AA	1 1/2	525	600
MAAHE-H24B-AA	2	700	800
MAAHE-H24B-BA	1 1/2	525	600
MAAHE-H24B-BA	2	700	800
MAAHE-H36B-AA	2 1/2	875	1000
MAAHE-H36B-AA	3	1050	1200
MAAHE-H36B-BA	2 1/2	875	1000
MAAHE-H36B-BA	3	1050	1200
MAAHE-H36B-CA	2 1/2	875	1000
MAAHE-H36B-CA	3	1050	1200
MAAHE-H60B-CA	4	1400	1600
MAAHE-H60B-CA	4 1/2	1575	1800
MAAHE-H60B-DA	4	1400	1600
MAAHE-H60B-DA	4 1/2	1575	1800

Step 4 - Refrigerant Piping Connections

⚠ WARNING

- Failure to follow this warning could result in personal injury. Wear eye protection.
- Coil is factory-charged with 15 psi nitrogen. The coil is under pressure and the TXV screen is in place behind the liquid line plug. DO NOT remove the liquid line plug first, always remove the suction line plug first to depressurize the coil.

NOTE

Factory nitrogen charge may escape past rubber plugs during storage. This does not indicate a leaking coil nor warrant the return of the coil. Size and install refrigerant lines according to information provided with the outdoor unit. Coil connection tube sizes are shown in Table 4-1. Route refrigerant lines to the coil in a manner that will not obstruct service access to the unit or removal of the filter. Do not use damaged, dirty, or contaminated tubing because it may plug the refrigerant flow-control device. ALWAYS evacuate the coil and field-supplied tubing before opening outdoor unit service valves.

Table 4-1: Piping Sizes

System Size		18K	24K	30K	36K
Maximum Piping Length	ft. (m)	98.4 (30)	164 (50)	164 (50)	246 (75)
Minimum Piping Length		10 (3)			
Max. outdoor-indoor height difference (OU higher than IU)		65.6 (20)	82 (25)	82 (25)	98.4 (30)
Max. outdoor-indoor height difference (IU higher than OU)		65.6 (20)	82 (25)	82 (25)	98.4 (30)
Gas Pipe (size - connection type)		ø3/4 (19)			
Liquid Pipe (size-connection)	in. (mm)	ø3/8 (9.52)			
Unit Connection (in. flare)	Liquid	3/8			
	Gas	3/4			
Adapter Required at Outdoor Unit (in. flare to flare or braze)	Liquid	3/8 flare→3/8 braze			
	Gas	3/4 flare→3/4 braze			

NOTE

Ensure that the length of the refrigerant pipe, the number of bends, and the drop height between the indoor and outdoor units meet the requirements shown in Table 4-1.

CONNECT REFRIGERANT, LIQUID, AND SUCTION LINES

For matched systems, use line sizes recommended in outdoor unit Installation Instructions.

Failure to follow this caution may result in property damage. Take precautions to ensure Aluminum tubes do not come in direct contact or allow for condensate runoff with a dissimilar metal. Dissimilar metals can cause galvanic corrosion and possible premature failure.

The coil can be connected to outdoor units using field-supplied tubing of refrigerant grade. Always evacuate the tubing and reclaim refrigerant when making connections or flaring tubing. Leak check connections before insulating the entire suction line. See Table for coil connection tube size.

1. Remove cabinet access door.
2. Remove the rubber plugs, the suction plug then the liquid plug, from the coil stubs, using a pulling and twisting motion. Hold coil stubs steady to avoid bending or distorting.
3. Remove the tubing plate with rubber grommets and slide the plate with grommets onto the refrigerant lines (field line-set), away from braze joints.
4. Fit the refrigerant lines into coil stubs. Wrap a heat-sinking material such as a wet cloth behind braze joints.

5. Wrap TXV and nearby tubing with a heat-sinking material such as a wet cloth.

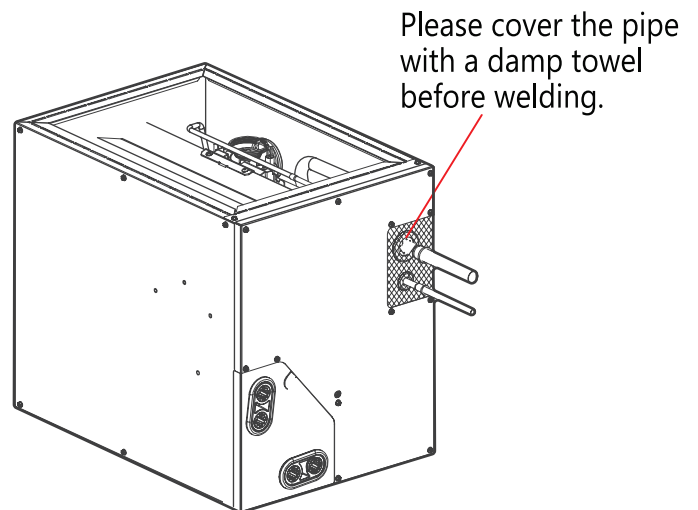

Fig. 4-1: Wrap Pipes Before Brazing

6. Use 1/2 Psig Nitrogen purge in the suction and out the liquid line.
7. Braze using a Sil-Fos or Phos-copper alloy. Do not use soft solder.
8. After brazing, allow joints to cool. Carefully remove the TXV bulb insulation and verify that the TXV bulb is securely fastened with a hose clamp. Tighten the screw a half-turn past hand tight with the TXV bulb placed in the indentation with full contact with the vapor line tube. Re-wrap the TXV bulb with insulation.
9. Leak check connections before insulating the entire suction line.
10. Slide tubing plate with rubber grommets over joints. Position tubing at the center of each grommet to ensure

an air seal around the tube. Reinstall the cabinet door.

⚠ CAUTION

Failure to follow this caution may result in product damage. To avoid valve damage to the refrigerant control device while brazing, valves must be wrapped with a heat-sinking material such as a wet cloth.

⚠ CAUTION

Failure to follow this caution may result in product damage. DO NOT BURY MORE THAN 36 IN. OF REFRIGERANT TUBING IN THE GROUND. If any section of tubing is buried, there must be a 6-in. vertical rise to the valve connections on the outdoor unit. If more than the recommended length is buried, the refrigerant may migrate to the cooler buried section during extended periods of unit shutdown, causing refrigerant slugging and possible compressor damage at start-up.

REFRIGERANT METERING DEVICE

These Coils have a factory-installed hard shut-off TXV designed only for use with R454B refrigerant. Use only with outdoor units designed for R454B.

Step 5 - Wiring Connections

⚠ WARNING

BEFORE PERFORMING ANY ELECTRICAL WORK, READ THESE WARNINGS.

- All wiring must comply with local and national electrical codes, and regulations and must be installed by a licensed electrician.
- All electrical connections must be made according to the Electrical Connection Diagram located on the panels of the indoor and outdoor units.
- If there is a serious safety issue with the power supply, stop work immediately. Explain your reasoning to the client and refuse to install the unit until the safety issue is resolved.
- Power voltage should be within 90-110% of rated voltage. Insufficient power supply can cause malfunction, electrical shock, or fire.
- Installation of an external surge suppressor at the outdoor disconnect is recommended.
- If connecting power to fixed wiring, a switch or circuit breaker that disconnects all poles and has a contact separation of at least 1/8in (3mm) must be incorporated into the fixed wiring. The qualified technician must use an approved circuit breaker or switch.
- Only connect the unit to an individual branch circuit. Do not connect another appliance to that Circuit.
- Make sure to ground the air conditioner properly.
- Every wire must be firmly connected. Loose wiring can cause the terminal to overheat, resulting in product malfunction and possible fire.
- Do not let wires touch or rest against refrigerant tubing, the compressor, or any moving parts within the unit.

- Never touch the electrical components soon after the power supply has been turned off to avoid getting an electric shock. After turning off the power, always wait 10 minutes or more before you touch the electrical components.
- Make sure that you do not cross your electrical wiring with your signal wiring. This may cause distortion, interference or possibly damage to circuit boards.
- No other equipment should be connected to the same power circuit.
- Connect the outdoor wires before connecting the indoor wires.

⚠ WARNING

BEFORE PERFORMING ANY ELECTRICAL OR WIRING WORK, TURN OFF THE MAIN POWER TO THE SYSTEM.

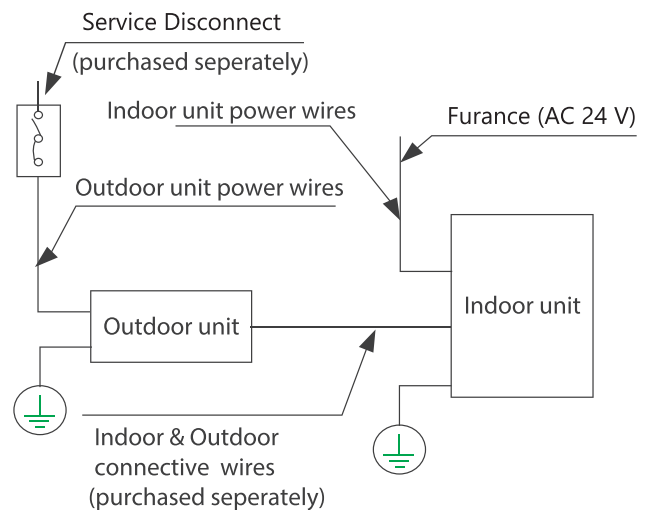

Fig. 5-1: Wiring Overview

NOTE

The diagrams are for explanation purposes only. Your machine may be slightly different. The actual diagram shall prevail.

Service Disconnect shall be selected as required by Local, regional, and national codes.

A-COIL MINI INTERFACE INSTALLATION

1. Choose Install Location - Priority should be given to installing it on the front of the coil, or you can choose to install it on the side or nearby walls as needed.

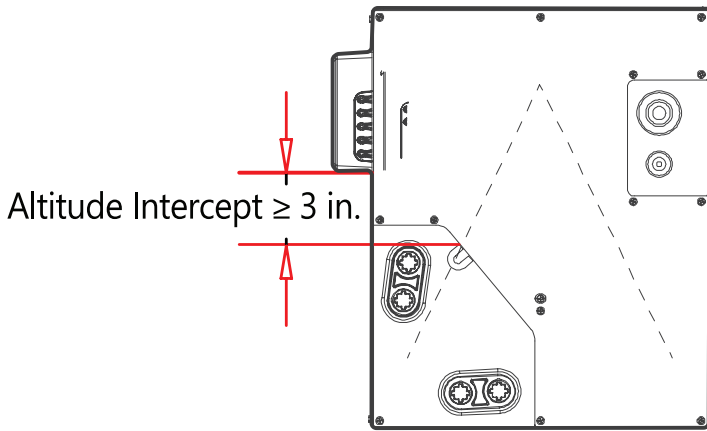

Fig. 5-2: Vertical Coil Installation

2. Installed on the side of the coil. (Vertical mounting, you can choose left or right)

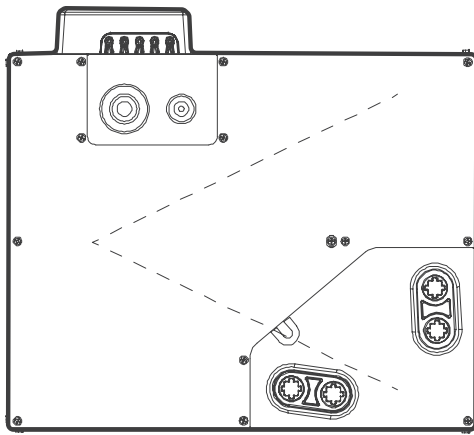

Fig. 5-3: Horizontal Coil Installation

3. Installed on the wall of the coil mount. (Horizontal mounting)

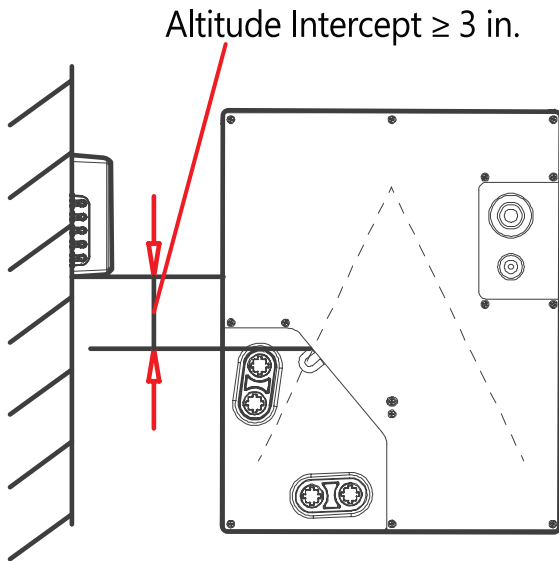

Fig. 5-4: Wall Mounted

4. Installed on the wall near the unit.

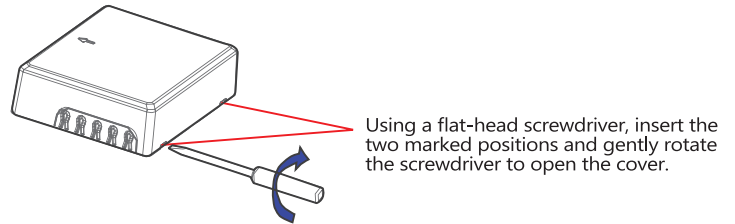

Fig. 5-5: Open the Cover

5. Dismantling the control box - Using a screwdriver, pull at the two positions shown in Fig. 5-5.

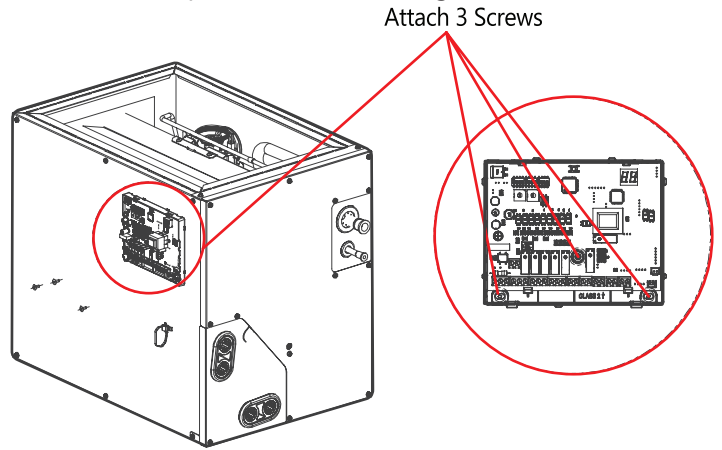

Fig. 5-5: Attach Board to Unit or Wall

6. Attach Board - Attach 3 screws. 2 screws will require drilling.

Power Wiring

The power to the unit must be disconnected before any wiring. Be sure to show the application of the ferrite clamp, room temperature sensor, and cable. Make a note to review the different application (scenarios) options for proper wiring. Make sure strain relief and proper conduit are used when connecting to the box and recommended use of metal-clad cable.

NOTE

Use copper wire only. Separate the power supply leads and communication leads by the strain relief or segregate the power supply leads from communication leads.

Instruction for installation of the critical-to-safety wiring connection of the leak detection sensor or leak detection system to the furnace assembly.

The wiring shall be not less than 18 AWG with a minimum insulation thickness of 1.58 mm or protected from damage. Critical-to-safety wiring is any field-installed wiring necessary to fulfill the requirements of minimum room area in the event of detection of a leak.

The appliance shall not be installed on furnaces with an inductive electrical greater than L_e as calculated as follows: the switched electrical load (L_e) in kVA is less than or equal to:

- $L_e = 5 \times (6,7/S_u)^4$ when breaking all phases;
- $L_e = 2,5 \times (6,7/S_u)^4$ when breaking two legs of a three-phase load, or when breaking one or two legs of a single-phase load.

Where L_e is the switched inductive electrical load in kilo volt-

amperes (kVA); Su is the burning velocity of a refrigerant in centimeters per second (cm/s).

Detection of a leak shall turn on the indoor fan at the highest available speed or turn it on to not less than minimum airflow (Qhmin).

7. Cut wiring exit outlet holes in the upper cover.
 - a. Use pliers to cut the upper cover and cut the left position according to the diagram.

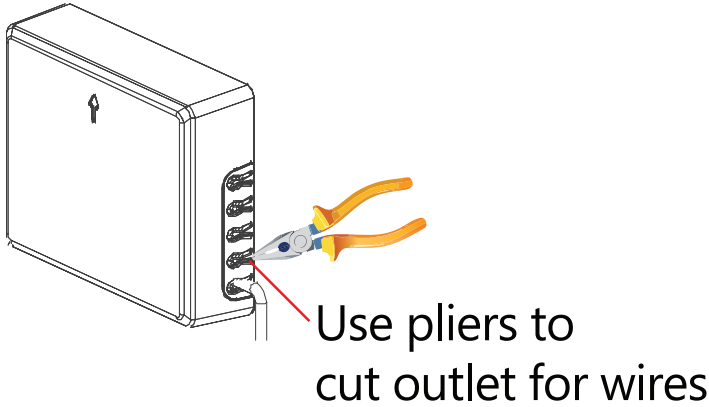

Fig. 5-6: Cut Outlet for Wires

- b. Close the cover.
 - c. Cut off the appropriate part according to the position of the wire outlet. If it is a single wire, you can cut a single wire hole, if there are multiple wires, you can cut off the cover along the maximum outline.
8. Close the lid - Close the cover to complete the installation of the control box.

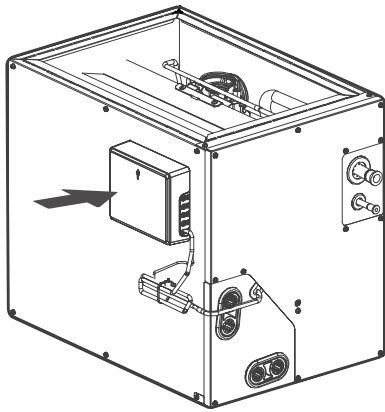

Fig. 5-7: Close the Cover of the Control Box

Table 5-1: Communication Wiring Sizes

Option	Communication Type	Reocommended Cable Size
1	Non-Polarity RS485 Communication (S1 - S2)	20 AWG (stranded shielded)
2	24 V communication	18 AWG 8 conductor thermostat wire

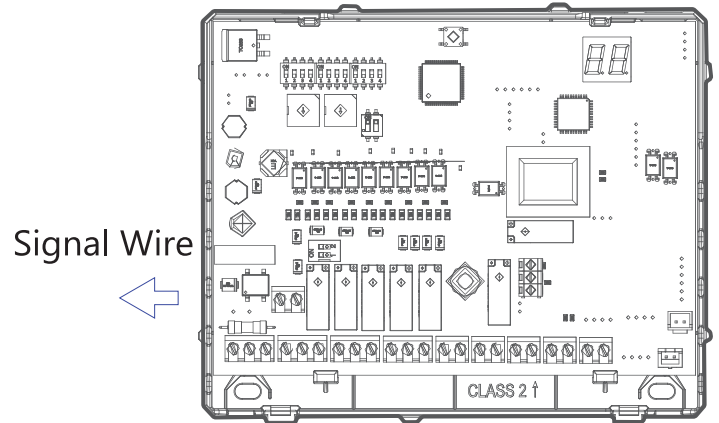

Fig. 5-8: Signal Wiring Location

WARNING

EQUIPMENT DAMAGE HAZARD

Failure to follow this caution may result in equipment damage or improper operation. Be sure to comply with local codes while running wire from the indoor unit to the outdoor unit. Every wire must be connected firmly. Loose wiring may cause the terminal to overheat or result in unit malfunction. A fire hazard may also exist. Ensure all wiring is tightly connected.



No wire should touch the refrigerant tubing, compressor or any moving parts. Disconnecting means must be provided and shall be located within sight and readily accessible from the air conditioner. Connecting cable with conduit shall be routed through the hole in the conduit panel.

Table 5-2: Inputs

Input Type	Input Rating	Terminals	Recommend Wire Range / Torque
Power Input	24 V ac, 60 Hz, 300 mA, Class 2	Terminal Block CN1-3(R), CN1- 2(C)	14-22 AWG / 0.5 N·m
Remote Control Signal Input	12 V DC, SELV	CN2	14-22 AWG / 0.5 N·m

Table 5-3: Communication

Type	Rating	Terminal	Recommend Wire Range / Torque
Communication Between Indoor and Outdoor Units	5 V DC, Class 2, Limited Energy (≤ 15 W)	CN17	14-22 AWG / 0.5 N·m
Communication Between the Data Conversion Board and External Thermostat	24 V AC, 60 Hz, Class 2	CN4, CN6, CN11	14-22 AWG / 0.5 N·m
Communication Between Data Conversion Module PWB and Centralized Controller	5 V DC, Class 2	CN3	14-22 AWG / 0.5 N·m
External Communication	18 V DC, Class 2, Limited Energy (≤ 15 W)	CN19	14-22 AWG / 0.5 N·m
Communication Between Data Conversion Module PWB and Refrigerant Sensor	5V DC, Class 2	CN5, CN8	14-22 AWG / 0.5 N·m

Table 5-4: Outputs

Type	Rating	Terminal	Recommend Wire Range / Torque
Control Device for Furnace (Relay RY7, RY8)	24 V AC, 60 Hz, Class 2, General Use (Signal Use)	CN9	14-22 AWG / 0.5 N·m
Control Device for Furnace (Relay, RY9, RY10)	24 V AC, 60 Hz, Class 2, General Use (Signal Use)	CN10	14-22 AWG / 0.5 N·m
Control Device for Outdoor Unit When full 24V communication (Relay, RY11)		CN43	14-22 AWG / 0.5 N·m

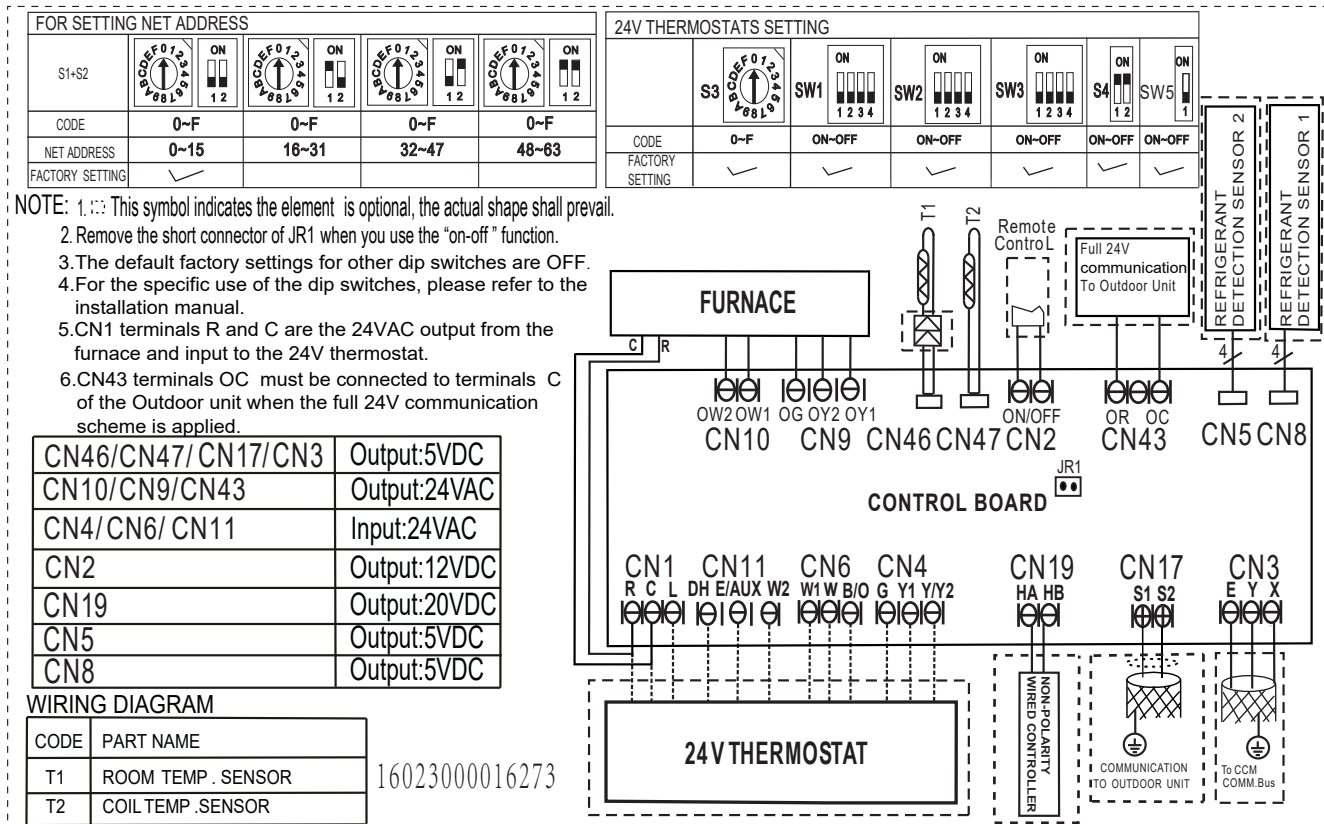

Fig. 5-9: Wiring Diagram

Control signals to the furnace are the standard thermostat control signals R, C, OW1, OW2, OG, OY1, and OY2.

Table 5-4: Control Signals To The Furnace

Connector	Usage
R	Provides 24VAC power from the furnace to the board.
C	The 24VAC common wire between the furnace and the board.
OW1	The first stage of the furnace command line from the board to the furnace. If the furnaces only have a W and do not have a W2, connect OW1 to the W of the furnace and make no connection with the OW2 signal wire.
OW2	The second stage of the furnace command line from the board to the furnace. OW2 cannot be ON unless OW1 is already ON.
OT1/OG	For 1-speed configuration, connect the OG signal to G of the furnace. For 2-speed configuration, connect the OG signal to G of the furnace and connect the OY1 signal to Y1 of the furnace.
OY2	For 1-speed configuration, connect this signal to Y of the furnace. In this configuration, the OY2 signal turns on when the fan is requested while in Cool mode or Heat mode using the heat pump. For 2-speed configuration, connect this signal to Y2 of the furnace. In this configuration, the OY2 signal turns on as follows: <ul style="list-style-type: none"> In Fan mode, Cool mode, or Heat mode with HP when high-speed fan is requested. In Auto Fan and Cool mode, the signal goes to high speed when the difference between room temperature and set point temperature is more than or equal to 1.5° C. The signal goes back to low speed when the temperature difference is less than 1° C. In Auto Fan and Heat mode with the HP, the signal goes to high speed when the difference between room temperature and set point temperature is less than or equal to -1.5° C. The signal goes back to low speed when the temperature difference is more than 0° C.

In addition:

Room temperature sensor to be installed in the return air.

Duct temperature sensor to be installed on the COIL as specified.

Step 6 - Specific Wiring Methods





WARNING

Please refer to the wiring nameplate for the wiring method. Do not connect the power cord to the communication line, as this may damage the system.

Table 6-1: Wiring Color Guide

THERMOSTAT				INDOOR UNIT	OUTDOOR UNIT
Heat - 2nd stage	W2	WHITE	→	W2 →	N/C
Emergency Heat - 1st stage	W1/E	BLACK	→	W1 →	D
		N/C		E	
		N/C		W	W
4 Way Valve	B	ORANGE	→	B →	B
Cool - 2nd stage	Y2	BROWN	→	Y2 →	Y2
Cool - 1st stage	Y	YELLOW	→	Y →	Y
Fan	G	GREEN	→	G →	G
	L	GRAY	→	L →	L
Power Common	C	BLUE	→	C →	C
Power	R	RED	→	R →	R
	DH	PURPLE	→	DH →	N/C

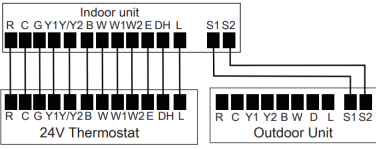
Scenario 1: EVOX Heat Pump and A-Coil 3rd Party 24 V Thermostat

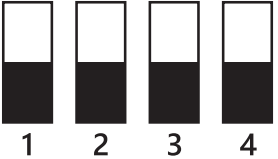
Matchup	Thermostat	Wiring	A-Coil SW1	ODU SW
Midea A-Coil+Midea ODU 	3rd Party 24 V Thermostat 	24 V communication* 	ON 	ON 

*This is a general wiring diagram. Use the diagram that comes with your selected 24 V thermostat.

Fig. 6-1: Scenario 1 Wiring Diagram and Dip Switch Settings

- The IDU and ODU need separate power or are from the ODU. See Step 4 - Power Wiring Connections.
- Bi Communication (IDU SW1-1&-4 and ODU SW-1) auto recognize
- IDU and ODU need 2 non-polarities (5 V RS485 communication through S1 S2)
- IDU and Thermostat Controller Communicate with 24 VAC signal
- Even in retrofit cases, there is no need to change the wire set (use the existing 24 V thermostat wire)
- Factory Default Setting on all Dip Switches are OFF
- When connecting a wired controller and 24 V thermostat will take a 24 V signal as a priority

Scenario 2: EVOX Heat Pump, A-Coil, and RS485 Communication





Matchup	Thermostat	Wiring	A-Coil SW1	ODU SW
Midea A-Coil+Midea ODU 	Midea Wired Thermostat 	Non-polarity RS485 communication 	ON 	ON 

Fig. 6-2: Scenario 2 Wiring Diagram and Dip Switch Settings





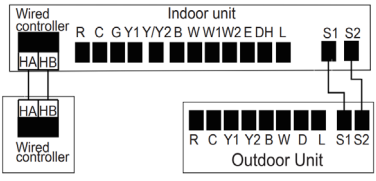

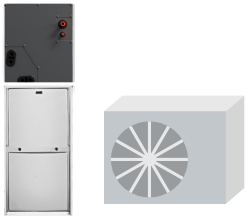

- The IDU and ODU need separate power or are from the ODU. See Step 4 - Power Wiring Connections.
- IDU and ODU need 2 non-polarity (5 V RS485 S1 and S2 communication)
- IDU and Midea wired controller (HA & HB with 20 VDC)

NOTE

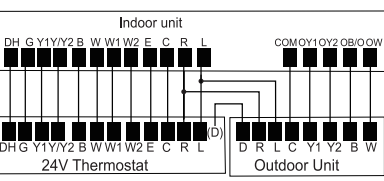
HA & HB is RS485 communication and cannot use 16 AWG wire as it will not fit the wired controller.

- Even in the retrofit case we don't need to change the wire set (use the existing 24 V thermostat wire)
- Factory Default Setting on all Dip Switches are OFF
- When connecting a wired controller and 24 V thermostat will take a 24 V signal as a priority

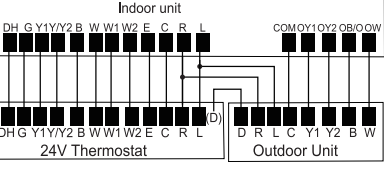
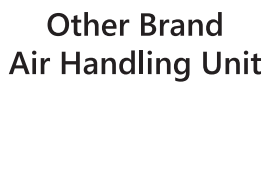
Scenario 3: Self-Adapt Mode with 3rd Party Equipment

Matchup	Thermostat	Wiring	A-Coil SW1	ODU SW
Midea A-Coil+Brand ODU 	3rd Party 24 V Thermostat 	24 V communication 	ON 	Other Brand Outdoor Unit 
Brand A-Coil+Midea ODU 	3rd Party 24 V Thermostat 	24 V communication 	Other Brand Air Handling Unit 	ON 

NOTE
For Brand A-Coil+Midea ODU, the 24V thermostat needs to be connected to a mainboard with a refrigerant sensor, and it should be able to cut off power to the outdoor unit in case of refrigerant leakage. Otherwise, there will be a risk of refrigerant leakage.

Fig. 6-3: Scenario 3 Wiring Diagram and Dip Switch Settings

- The IDU and ODU need separate power or are from the ODU. See Step 4 - Power Wiring Connections or the 3rd party unit's instructions.
- IDU and ODU without any wire communication
- IDU and ODU control by 24 V thermostat (24 VAC)
- Factory Default Setting on all Dip Switches is OFF
- When the connected wired controller and 24 V thermostat will take the 24 V signal as a priority.

24 V Connection Diagrams

Table 6-2: Control Logic

Terminal	Location	Function
R	Thermostat/Indoor Unit/Outdoor Unit	24 V Power Connection
C	Thermostat/Indoor Unit/Outdoor Unit	Common
G	Indoor Unit	Fan Control
Y1	Thermostat/Indoor Unit/Outdoor Unit	Low Demand
Y2	Thermostat/Indoor Unit/Outdoor Unit	High Demand
B	Thermostat/Indoor Unit/Outdoor Unit	Heating Reversing Valve
W	Thermostat/Indoor Unit/Outdoor Unit	Heating Control
W1	Thermostat/Indoor Unit	Stage 1 Electric Heating
W2	Thermostat/Indoor Unit	Stage 2 Electric Heating
E/AUX	Indoor Unit	Emergency Heating
D	Outdoor Unit	Defrost - (24 V output signal)
L	Thermostat/Indoor Unit/Outdoor Unit	System Fault - (24 V output signal)
DH/BK	Thermostat/Indoor Unit	Dehumidification/Zoning Control
DS	Indoor Unit	Reserved Signal
W2	Thermostat/Indoor Unit	Second Stage Heating

NOTE
Terminal D is now energized when the outdoor unit goes into defrost mode and can be used to enable electric heat. This feature is unavailable when the outdoor unit communicates with the indoor unit via non-polarity RS485 Communication S1-S2.

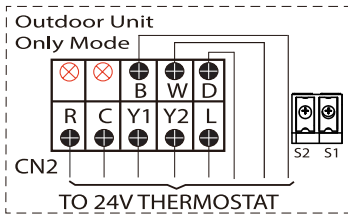

24 V must never be connected to S1 – S2. All wiring must be in compliance with the above scenarios. Incorrect wiring will cause irreversible damage to the control.

Fig. 6-4: Never Connect 24 V to S1-S2

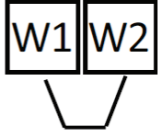

S4-1:

Default ON: For single-stage supplemental heat, W1 and W2 are connected.

OFF: W1 and W2 are controlled independently for dual-stage supplemental heat. feature is enabled through the thermostat.

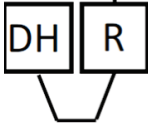

S4-2:

Default ON: Dehumidification control not available.

OFF: The dehumidification feature is enabled through the thermostat.

NOTE

CN43 terminals OC of A-COIL Mini Interface must be connected to the outdoor unit when the full 24V communication scheme is applied. That will stop the operation of the outdoor unit for safety if the refrigerant leakage happens.

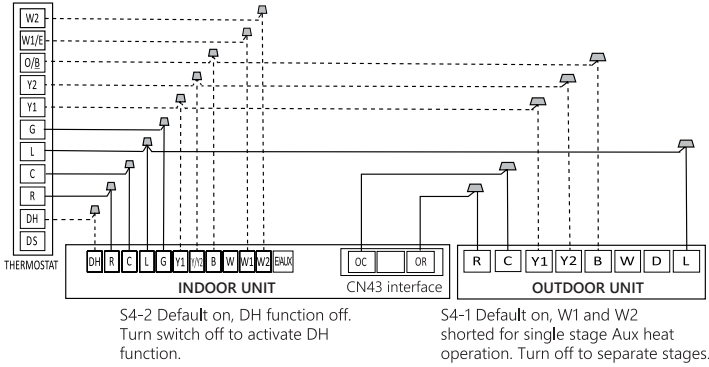

Fig. 6-5: Wiring for 4H and 2C Thermostat

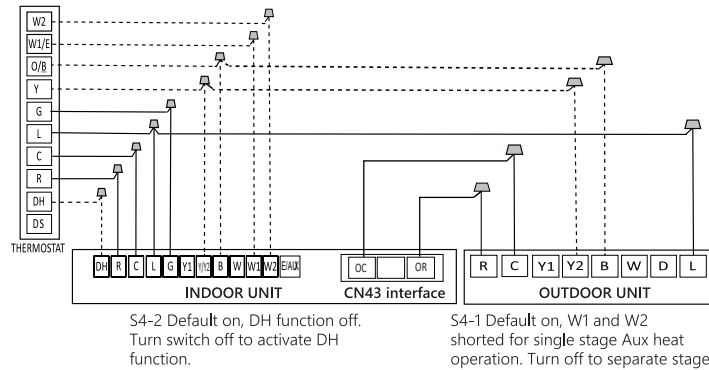

Fig. 6-6: Wiring for 3H and 1C Thermostat

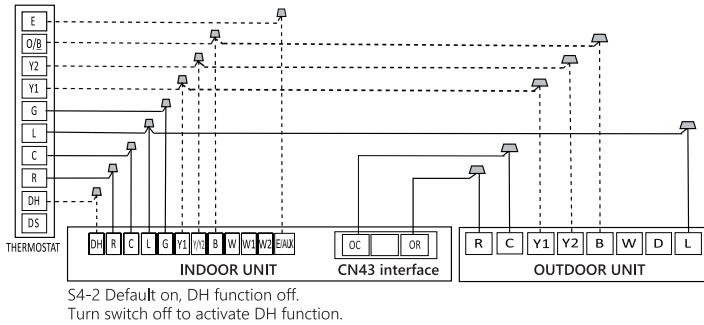

Fig. 6-7: Wiring for 3H and 2C Thermostat

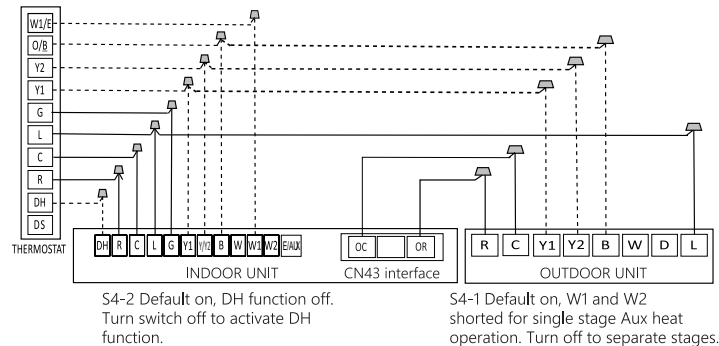

Fig. 6-8: Wiring for 3H and 2C Thermostat

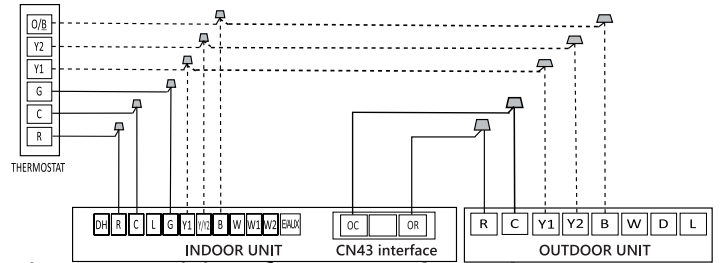

Fig. 6-9: Wiring for 2H and 2C Thermostat

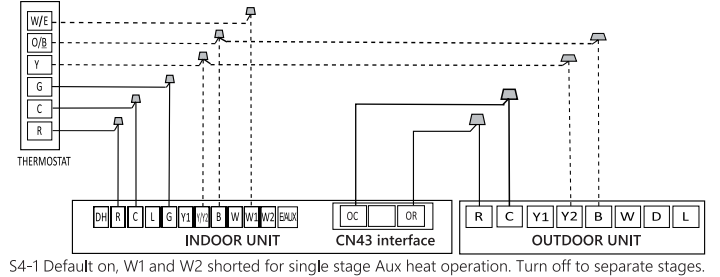

Fig. 6-10: Wiring for 2H and 1C Thermostat

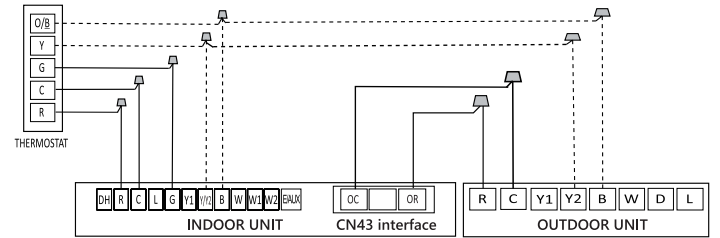

Fig. 6-11: Wiring for 1H and 1C Thermostat

DIP Switch Definitions

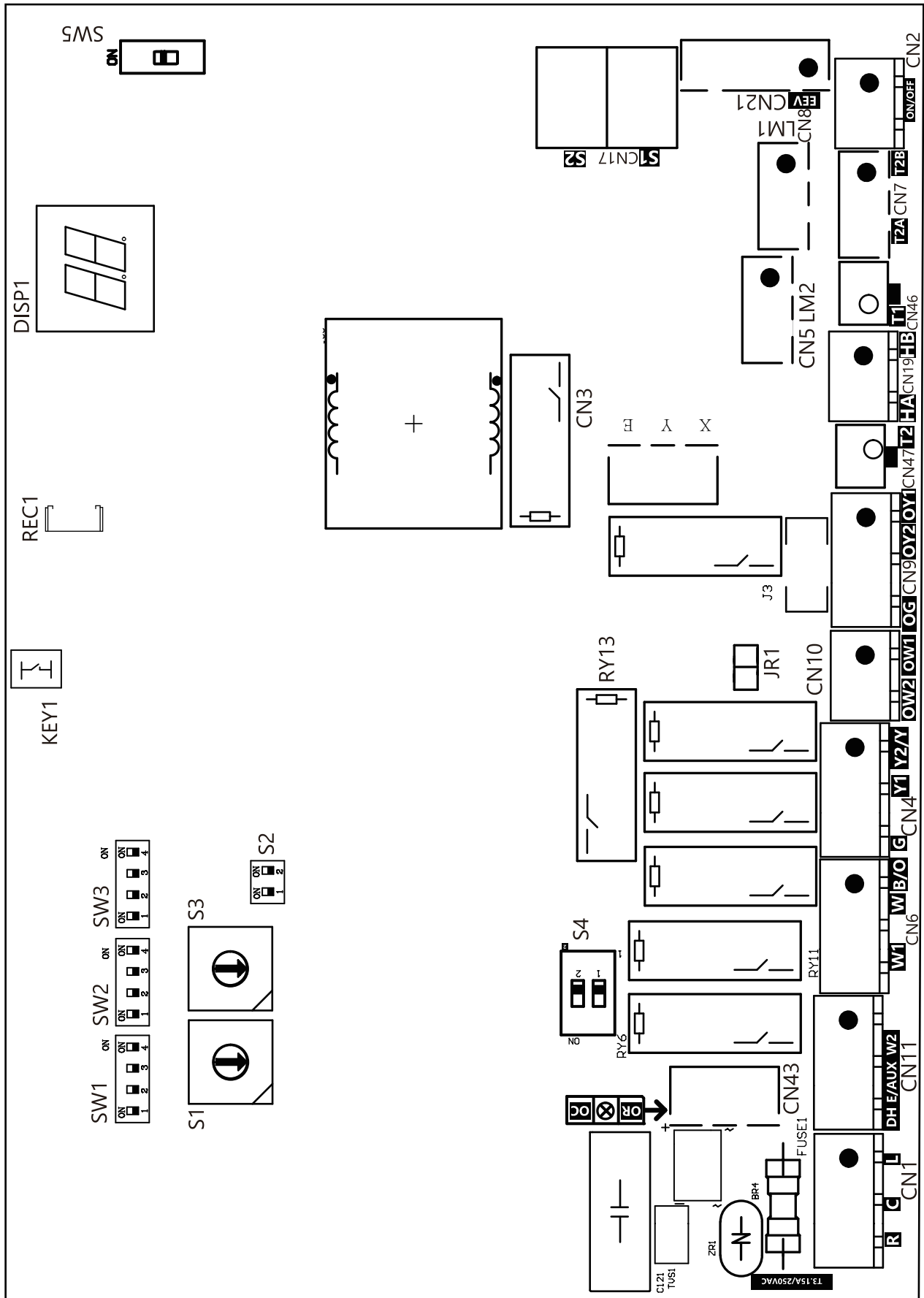

Fig 6-12: Dip Switch Layout
EVOX A-Coil Evaporator

Function DIP switch settings:

The 24 V thermostat mode needs to refer to the following settings:

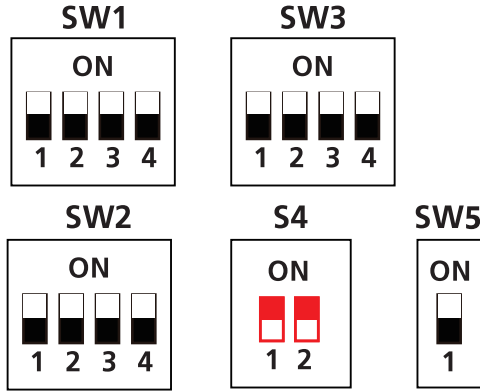

Fig. 6-13: 24 V Thermostat Settings

Table 6-2: Function combination table of SW1-1 and SW1-4

SW1	Control Type	IDU & ODU Connection	Note
	Wired controller / 24 V thermostat	(S1+S2) / 24 V connection	Auto Discovery
	Wired controller	S1+S2	Scenario 2
	24 V Thermostat	S1+S2	Scenario 1
	24 V Thermostat	24 V connection	Scenario 3

Table 6-3: Indoor Unit Dial Code

No.	Dial Code	Control Scenario	Function	ON	OFF	Note
1	SW1-2	1,2,3	Anti-cold blow protection option	NO	[Default] YES	
2	SW1-3	1,2,3	Single cooling / heating and cooling options	Cooling	[Default] Cooling & Heating	
3	SW2-1	2	Temperature differential to active first stage furnace heating for HP+furnace mode.	35°F (2°C)	[Default] 4°F (2°C)	
4	SW2-4	1	Compressor	The operation of heat pump is limited by the outdoor temperature, and the operation of auxiliary heat is not limited. The system makes judgments according to the following rules: 1) The compressor can be operated when the outdoor temperature is \geq S3 DIP switch temperature +2 °C. 2) The compressor cannot be operated when the outdoor temperature is lower than the S3 DIP switch temperature.	[Default]The operation of heat pump is limited by the outdoor temperature, and the operation of auxiliary heat is not limited. The system makes judgments based on the following rules: 1) The compressor cannot be operated when the outdoor temperature is lower than the S3 DIP switch. 2) The compressor can be operated when the outdoor temperature is \geq S3 DIP switch temperature +2 °C.	
5	SW2-4	2	Compressor/Auxiliary heat outdoor ambient lockout	The operation of heat pump is limited by the outdoor temperature, and the operation of auxiliary heat is not limited. The system makes judgments according to the following rules: 1) The compressor can be operated when the outdoor temperature is \geq S3 DIP switch temperature +2 °C. 2) The compressor cannot be operated when the outdoor temperature is lower than the S3 DIP switch temperature.	[Default]Only one heat pump or auxiliary heat can be operated .The system makes judgments according to the following rules: 1) When the outdoor temperature is lower than the S3 DIP switch temperature,the compressor is not allowed to be operated, but auxiliary heat is allowed to be operated ; 2) When the outdoor temperature is \geq S3 DIP switch temperature +2 (°C), the compressor can be operated, but auxiliary heat cannot be operated.	SW2-4 and S3 need to working together
6	Rotary Switch S3	1,2	Set outdoor temperature Limitation (for auxiliary heating or compressor)	See Table 6-4: Table A		
7	SW3-1	1	The system automatically stages up capacity to satisfy the set point. This adds 1 to 5°F to the user set point in the calculated control point to increase capacity and satisfy the user set point.	30 minutes	[Default] 90 minutes	
8	SW3-2	1	Cooling and heating Y/Y2 temperature differential adjustment.	Compressor slower speed	[Default] Faster Compressor	Only affects compressor

Table 6-3: Indoor Unit Dial Code (continued)

No.	Dial Code	Control Scenario	Function	ON	OFF	Note
9	SW3-3	2	Temperature differential to active second-stage furnace heating for furnace only or HP+ furnace mode.	37°F (3°C)	[Default] 35°F (2°C)	
10	SW4-1	1,3	Default ON	[Default] For single-stage supplemental heat, W1 and W2 are connected	For dual-stage supplemental heat, W1 and W2 are controlled independently	
11	S4-2	1,3	DH function selection	[Default] Dehumidification control not available	Dehumidification feature is enabled through thermostat	
12	SW5	1,2,3	Selection of the second Refrigerant Sensor	Both Refrigerant Sensor are used	Only use the first Refrigerant Sensor, interface is CN8	

Control Scenario	24 V Tstat, S1+S2	1
	Wired Controller S1+S2	2
	Full 24 V	3

Table 7-1: Recommended Insulation Thickness

Humidity < 80% RH	Humidity ≥ 80% RH
3/8 in./10 mm	5/8 in./15 mm

Table 6-4: Table A

S3	S3 (°F)	S3 (°C)
O	OFF	OFF
1	-22	-30
2	-18	-30
3	-15	-26
4	-11	-24
5	-8	-22
6	-4	-20
7	3	-16
8	10	-12
9	18	-8
A	25	-4
B	32	0
C	36	2
D	39	4
E	43	6
F	46	8

Table 6-5: Wired Remote Control Modes

FURNACE	Single-furnace heating
Heat PUMP	HP heating
DUAL FUEL	Furnace heating, HP heating automatic control

Step 7 - Insulate the Piping

After the unit is installed and tested, wrap the piping and brass fittings with foam tape.

You will need to wrap all the connected copper pipes into the insulation.

Wrap insulation around the piping. Direct contact with the bare piping may result in burns or frostbite. Ensure the pipe is properly connected. Over-tightening may damage the bell mouth and under-tightening may lead to leakage.

Insulation material selection for refrigerant pipe

- The burning performance should be over 248°F/120°C.
- Choose insulation materials according to local laws.

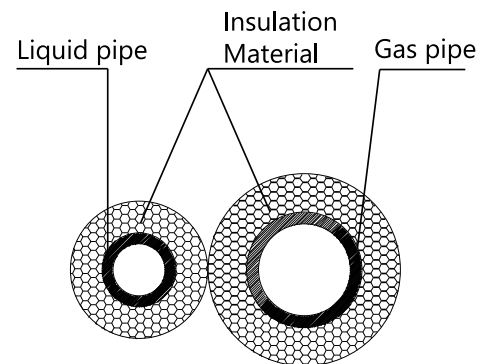

Fig. 7-1: Insulate Both Pipes Separately

- Gas and liquid pipes must be insulated separately. Insulating them together will decrease the performance of the air conditioner.
- The insulation material at the joint pipe shall be 2-4 in.in./5-10 cm longer than the gap of the insulation material.
- The insulation material at the joint pipe shall be inserted into the gap of the insulation material.
- The joint pipe's insulation material shall be tightly banded to the gas and liquid pipes.

Be sure not to bind the insulation material or over-tighten it, this may compress the air in the material, cause bad insulation, and cause early decay of the material.

Insulation of drainage pipe

The temperature of condensate drainage water is very low. If the insulation is not enough, it will form dew and leak. This can cause damage to ceilings or walls.

Insulation material selection for drainage pipe

- The insulation material should be made of flame retardant material, and the flame retardancy of the material should be selected according to the local law.
- The thickness of the insulation layer is usually above 10 mm/0.39 in..
- Use specific glue to paste the seam of insulation material, and then bind with adhesive tape. The width of the tape shall not be less than 3/8 in./5 cm.
- The single pipe should be insulated before connecting to another pipe, the joint part should be insulated after

the drainage test.

- There should be no insulation gap between the insulation material.

Test Run

CAUTION

Failure to perform the test run may result in unit damage, property damage, or personal injury.

Before the Test Run

A test run must be performed after the entire system has been completely installed. Confirm the following points before performing the test:

- Indoor and outdoor units are properly installed.
- Piping and wiring are properly connected.
- No obstacles near the inlet and outlet of the unit that might cause poor performance or product malfunction.
- The refrigeration system does not leak.
- The drainage system is unimpeded and draining to a safe location.
- Heating insulation is properly installed.
- Grounding wires are properly connected.
- Length of the piping and additional refrigerant capacity have been recorded.
- Power voltage is the correct voltage for the air conditioner

Test run Instructions

- Open both the liquid and gas service valves.
- Turn on the main power switch and allow the unit to warm up.
- Set the air conditioner to COOL mode.
- For the Indoor Unit
 - Double-check to see if the room temperature is being registered correctly.
 - Check to see that the drainage system is unimpeded and draining smoothly.
 - Ensure there is no vibration or abnormal noise during operation.
- For the Outdoor Unit
 - Check to see if the refrigeration system is leaking.
 - Make sure there is no vibration or abnormal noise during operation.
 - Ensure the wind, noise, and water generated by the unit do not disturb your neighbors or pose a safety hazard.
- Drainage Test

- Ensure the drainpipe flows smoothly. New buildings should perform this test before finishing the ceiling.
- Turn on the main power switch and run the air conditioner in COOL mode.
- Check to see that the water is discharged. It may take up to one minute before the unit begins to drain depending on the drainpipe.
- Make sure that there are no leaks in any of the piping.
- Stop the air conditioner. Turn off the main power switch and reinstall the test cover.

NOTE

If the unit malfunctions or does not operate according to your expectations, please refer to the Troubleshooting section of the Service Manual before calling customer service.

Care And Maintenance

To continue high performance and minimize possible equipment failures, periodic maintenance must be performed on this equipment. Consult your local dealer as to the proper frequency of maintenance, but it should be done at least annually. The ability to properly perform maintenance on this equipment requires certain mechanical skills and tools. If you do not possess these, contact your dealer for maintenance. The only consumer service recommended or required is filter replacement or cleaning monthly.

CAUTION

Failure to follow this caution may result in environmental damage. Remove and recycle all components or materials (i.e., oil, refrigerant, etc.) before unit final disposal.

Troubleshooting

SAFETY PRECAUTIONS

If any of the following conditions occur, turn off your unit immediately!

- You smell a burning odor.
- The unit emits loud or abnormal sounds.
- A power fuse blows or the circuit breaker frequently trips.
- Water or other objects fall into or out of the unit.

DO NOT ATTEMPT TO FIX THESE YOURSELF! CONTACT AN AUTHORIZED SERVICE PROVIDER IMMEDIATELY!

The following problems are not malfunctions and, in most situations, will not require repairs.

Table TS-1: Common Issues

Issue	Possible Causes
The unit does not turn on when pressing the ON/OFF button	The Unit has a 3-minute protection feature that prevents the unit from overloading. The unit cannot be restarted within three minutes of being turned off.
	Cooling and Heating Models: If the Operation light and PRE-DEF (Pre-heating/ Defrost) indicators are lit up, the outdoor temperature is too cold, and the unit's anti-cold wind is activated to defrost the unit.
	In Cooling-only Models: If the "Fan Only" indicator is lit up, the outdoor temperature is too cold, and the unit's anti-freeze protection is activated to defrost the unit.
The unit changes from COOL/HEAT mode to FAN mode	The unit may change its setting to prevent frost from forming on the unit. Once the temperature increases, the unit will start operating in the previously selected mode again.
	The set temperature has been reached, at which point the unit turns off the compressor. The unit will continue operating when the temperature fluctuates again.
The indoor unit emits a white mist	In humid regions, a large temperature difference between the room's air and the conditioned air can cause white mist.
Both the indoor and outdoor units emit white mist	When the unit restarts in HEAT mode after defrosting, a white mist may be emitted due to moisture generated from the defrosting process.
The indoor unit makes noises	A squeaking sound is heard when the system is OFF or in COOL mode. The noise is also heard when the drain pump (optional) is in operation.
	A squeaking sound may occur after running the unit in HEAT mode due to the expansion and contraction of the unit's plastic parts.
Both the indoor unit and outdoor unit make noises	Low hissing sound during operation: This is normal and is caused by refrigerant gas flowing through both indoor and outdoor units.
	Low hissing sound when the system starts, has just stopped running, or is defrosting: This noise is normal and is caused by the refrigerant gas stopping or changing direction.
	Squeaking sound: Normal expansion and contraction of plastic and metal parts caused by temperature changes during operation can cause squeaking noises.
The outdoor unit makes noises	The unit will make different sounds based on its current operating mode.
Dust is emitted from either the indoor or outdoor unit	The unit may accumulate dust during extended periods of non-use, which will be emitted when the unit is turned on. This can be mitigated by covering the unit during long periods of inactivity.
	The unit may absorb odors from the environment (such as furniture, cooking, cigarettes, etc.) which will be emitted during operations.
The unit emits a bad odor	The unit's filters have become moldy and should be cleaned.
The fan of the outdoor unit does not operate	During operation, the fan speed is controlled to optimize product operation.

When troubles occur, please check the following points before contacting a repair company.

Table TS-2: Troubleshooting

Problem	Possible Causes	Solution
Poor Cooling Performance	The temperature setting may be higher than the ambient room temperature	Lower the temperature setting
	The heat exchanger on the indoor or outdoor unit is dirty	Clean the affected heat exchanger
	The air filter is dirty	Remove the filter and clean it according to the instructions
	The air inlet or outlet of either unit is blocked	Turn the unit off, remove the obstruction, and turn it back on
	Doors and windows are open	Make sure that all doors and windows are closed while operating the unit
	Excessive heat is generated by sunlight	Close windows and curtains during periods of high heat or bright sunshine
	Too many sources of heat in the room (people, computers, electronics, etc.)	Reduce the amount of heat sources
	Low refrigerant due to leak or long-term use	Check for leaks, re-seal if necessary, and top of refrigerant
The unit is not working	Power failure	Wait for the power to be restored
	The power is turned off	Turn on the power
	The fuse is burned out	Replace the fuse
	The Unit's 3-minute protection has been activated	Wait three minutes after restarting the unit
	Timer is activated	Turn timer of
The unit starts and stops frequently	There's too much or too little refrigerant in the system	Check for leaks and recharge the system with refrigerant.
	Incompressible gas or moisture has entered the system.	Evacuate and recharge the system with refrigerant
	The system circuit is blocked	Determine which circuit is blocked and replace the malfunctioning piece of equipment
	The compressor is broken	Replace the compressor
	The voltage is too high or too low	Install a manostat to regulate the voltage
Poor heating performance	The outdoor temperature is extremely low	Use an auxiliary heating device
	Cold air is entering through doors and windows	Make sure that all doors and windows are closed during use
	Low refrigerant due to leak or long-term use	Check for leaks, re-seal if necessary, and top of refrigerant

Appendix

Table AP-1: 24 V Signal Chart (Cooling & Heating)

Mode	Priority	G	Y1	Y/Y2	B	W	W1	W2	E/AUX	DH	Display
OFF	/	0	0	0	0	0	0	0	0	*	00
FAN	7	1	0	0	*	0	0	0	0	*	01
Cooling stage 1	6	*	1	0	0	0	0	0	0	1	02
Cooling stage 2		*	*	1	0	0	0	0	0	1	03
Dehumidification 1		*	1	0	0	0	0	0	0	0	04
Dehumidification 2		*	*	1	0	0	0	0	0	0	05
Heat pump stage 1	5	*	1	0	1	0	0	0	0	1	06
Heat pump stage 2		*	*	1	1	0	0	0	0	1	
Heat pump stage 2		*	*	*	*	1	0	0	0	1	07
Furnace	3	*	0	0	*	0	1	0	0	*	12
Furnace		*	0	0	*	0	0	1	0	*	
Furnace		*	0	0	*	0	1	1	0	*	12
Furnace	4	*	1	0	1	0	1	0	0	1	12
Furnace		*	1	0	1	0	0	1	0	1	
Furnace		*	*	1	1	0	1	0	0	1	
Furnace		*	*	*	*	1	1	0	0	1	
Furnace		*	*	1	1	0	0	1	0	1	12
Furnace		*	*	*	*	1	0	1	0	1	
Furnace		*	1	0	1	0	1	1	0	1	
Furnace		*	*	1	1	0	1	1	0	1	
Furnace	1	*	*	*	*	*	*	*	1	*	12
Heating zone control	2	*	1	0	1	0	*	*	0	0	13
Heating zone control		*	*	1	1	0	*	*	0	0	
Heating zone control		*	*	*	*	1	*	*	0	0	

Note:

1: 24 V signal

0: No 24 V signal

*: 1 or 0.

The A-Coil will turn off if the 24 V input cannot meet the table.

Table AP-2: 24 V Signal Chart (Cooling Only)

Mode	Priority	G	Y1	Y/Y2	B	W	W1	W2	E/AUX	DH	Display
OFF	/	0	0	0	0	0	0	0	0	*	00
FAN	7	1	0	0	*	0	0	0	0	*	01
Cooling stage 1	6	*	1	0	0	0	0	0	0	1	02
Cooling stage 2		*	*	1	0	0	0	0	0	1	03
Dehumidification 1		*	1	0	0	0	0	0	0	0	04
Dehumidification 2		*	*	1	0	0	0	0	0	0	05
Furnace	5	*	1	0	1	0	0	0	0	1	12
Furnace		*	*	1	1	0	0	0	0	1	12
Furnace		*	*	*	*	1	0	0	0	1	
Furnace	3	*	0	0	*	0	1	0	0	*	12
Furnace		*	0	0	*	0	0	1	0	*	
Furnace		*	0	0	*	0	1	1	0	*	12
Furnace	4	*	1	0	1	0	1	0	0	1	12
Furnace		*	1	0	1	0	0	1	0	1	
Furnace		*	*	1	1	0	1	0	0	1	
Furnace		*	*	*	*	1	1	0	0	1	
Furnace		*	*	1	1	0	0	1	0	1	
Furnace		*	*	*	*	1	0	1	0	1	
Furnace		*	1	0	1	0	1	1	0	1	
Furnace	1	*	*	1	1	0	1	1	0	1	12
Furnace		*	*	*	*	1	1	1	0	1	
Furnace		*	*	*	*	1	1	1	0	1	
Furnace	2	*	1	0	1	0	*	*	0	0	12
Furnace		*	*	1	1	0	*	*	0	0	
Furnace		*	*	*	*	1	*	*	0	0	

Note:

1: 24 V signal

0: No 24 V signal

*: 1 or 0.

The A-Coil will turn off if the 24 V input cannot meet the table.

Indoor Unit Diagnostic Guide

For ease of service, systems are equipped with diagnostic code display LEDs on the indoor and outdoor units. Outdoor diagnostics are displayed on the outdoor unit microprocessor board. The indoor unit may display a few error codes that might relate to the outdoor unit's problems. If possible, always check the diagnostic codes displayed on the indoor unit first. The diagnostic codes displayed on the outdoor units are listed in the outdoor unit manual.

Table AP-3: Indoor Unit Diagnostic Codes

Display	Error Information
E _C 07	ODU fan speed out of control
E _C 0d	ODU malfunction
E _C 5 1	ODU EEPROM parameter error
E _C 52	ODU coil temp. sensor (T3) error
E _C 53	ODU ambient temp. sensor (T4) error
E _C 54	COMP. discharge temp. sensor(TP) error
E _C C 1	Other IDU refrigerant sensor detects leakage (Multi-zone)
E _H 00	IDU EEPROM malfunction
E _H 03	IDU fan speed out of control
E _H 0A	IDU EEPROM parameter error
E _H 0b	IDU main control board and display board communication error
E _H 0E	Water-level alarm malfunction
E _H 3A	External fan DC bus voltage is too low protection
E _H 3b	External fan DC bus voltage is too high fault
E _H 60	IDU room temp. sensor (T1) error
E _H 6 1	IDU coil temp. sensor(T2) error
E _H 6A	Communication malfunction between indoor unit and external fan module
E _H C 1	Refrigerant sensor detects leakage
E _H C2	Refrigerant sensor is out of range and leakage is detected
E _H C3	Refrigerant sensor is out of range
E _L 0 1	IDU & ODU communication error
E _L 0C	System lacks refrigerant
E _L 16	Communication malfunction between adapter board and outdoor main board
F _H C C	Refrigerant sensor error
F _L 09	Mismatch between the new and old platforms
P _C 00	ODU IPM module protection
P _C 0 1	ODU voltage protection
P _C 02	Compressor top (or IPM) temp. protection
P _C 03	Pressure protection (low or high pressure)
P _C 04	Inverter compressor drive error
P _C 0L	Low ambient temperature protection
- - - -	IDUs mode conflict(Multi-zone)

North American HVAC Products Ltd.

Add.: #100 5118 N Fraser Wy, Burnaby, BC V5J 0H1

Tel: 604-430-8496 info@nahvac.com www.nahvac.com

Midea reserves the right to change the specifications of the product, and to withdraw or replace products without prior notification or public announcement.
Midea is constantly developing and improving its products.