

R454b Refrigerant

SUBMITTAL DATA SHEET



Series Name: Regular Heat Pancake Series
Model Number: MAPHE-H18B-2A/MO1BE-H18B-2A

Air Handler Heat Pump System

Location:	Approval:
Engineer:	Date:
Submitted to:	Construction:
Submitted by:	Unit #:
Reference:	Drawing #:



INDOOR SPECIFICATION

ESP(in.W.G)	0-0.8	
Indoor Air Flow (Turbo/H/M/L/Si) (CFM)	600 / 565 / 530 / 489 / 489	
Indoor Noise Level (Turbo/H/M/L/Si) (dBA)	55.5 / 55.5 / 52.5 / 50.5 / 50.5	
Dimension (W×D×H)	inch	43-1/4 x 23-3/8 x 10-15/16
	mm	1098 x 593 x 278
Package (W×D×H)	inch	47-1/4 x 26-3/4 x 13-5/8
	mm	1200 x 680 x 345
Net/Gross Weight	lbs	118/127.87
	kg	53.5/58

OUTDOOR SPECIFICATION

Compressor Type	ROTARY	
Compressor Model	KSN140D58UFZ	
Refrigerant	R454B	
Refrigerant Oil Charge(mL)	440	
Refrigerant Oil	VG74	
Outdoor Air Flow (Max) (CFM)	1,451	
Outdoor Noise Level (dBA)	56	
Dimension (W×D×H)	inch	31-3/4 x 13 x 21-3/4
	mm	805 x 330 x 554
Package (W×D×H)	inch	36 x 14-9/16 x 24-3/16
	mm	915 x 370 x 615
Net/Gross Weight	lbs	77 / 84
	kg	35 / 38

EFFICIENCY

Cooling		Heating	
SEER2	16.8	HSPF2-4	8.8
EER2	11.5	COP	3.5

PERFORMANCE of Cooling

Cooling (Btu/hr)	
Rated Capacity	18,000
Min/Max Capacity	6,000~20,000
Moisture Removal(L/h)	1.46
Standard Operating Range(°F/°C)	-13~122(-25 ~ 50)
Rated Cooling Conditions:	Indoor: 80°F DB/67°F WB Outdoor: 95°F DB/75°F WB

PERFORMANCE of Heating

Heating (Btu/hr)	
1. @ 47°F Rated	18,000
1. @ 47°F Min/Max Capacity	5,500~19,600
2. @ 17°F Rated	11,800
3. @ 5°F Rated: Capacity / COP	11,400/1.8
3. @ 5°F Max: Capacity	11,400
Standard Operating Range(°F/°C)	-13~75(-25 ~ 24)
1. Rated Heating Conditions:	Indoor: 70°F DB/60°F WB Outdoor: 47°F DB/43°F WB
2. Rated Heating Conditions:	Indoor: 70°F DB/60°F WB Outdoor: 17°F DB/15°F WB
3. Heating Conditions, Compressor Operating at Max. Frequency	Indoor: 70°F DB/60°F WB Outdoor: 5°F DB/5°F WB

ELECTRICAL

Indoor Power Supply	115/208/230,60Hz,1Ph
Indoor MCA 115V/(208/230V)	115V:6;208/230V:5
Indoor MOP	15.0
Outdoor Power Supply	208/230,60Hz,1Ph
Outdoor MCA	16.0
Outdoor MOP	20.0
Communication Wiring	AWG 20/2
Compressor RLA	10
Outdoor Fan Motor RLA	0.8
Outdoor Fan Motor W	34
Indoor Fan Motor RLA	115V:4;208/230V:3.5
Indoor Fan Motor W	250
System Power Input @ Cooling (W)	1,565(600 ~ 1,900)
System Power Input @ Heating (W)	1,512(390 ~ 1,700)
MCA: Min. circuit amps (A)	MOCP: Max. over current protection (A)
RLA: Rated load amps (A)	W: Fan motor rated output (W)

PIPING

Throttle type(Indoor)	EXV
Throttle type(Outdoor)	EXV
Liquid Size	3/8" (9.52mm)
Gas Size	3/4" (19mm)
Max. Piping Length(ft/m)	98(30)
Max. Height Difference(ft/m)	66(20)
Max. Pre-charged Length(ft/m)	25(7.5)
Refrigerant Pre-charged Amount(oz/kg)	51(1.45)
Additional Charge of Refrigerant(oz/ft)/(g/m)	0.7(65)
Connection Method	Flared

Indoor Unit Dimension

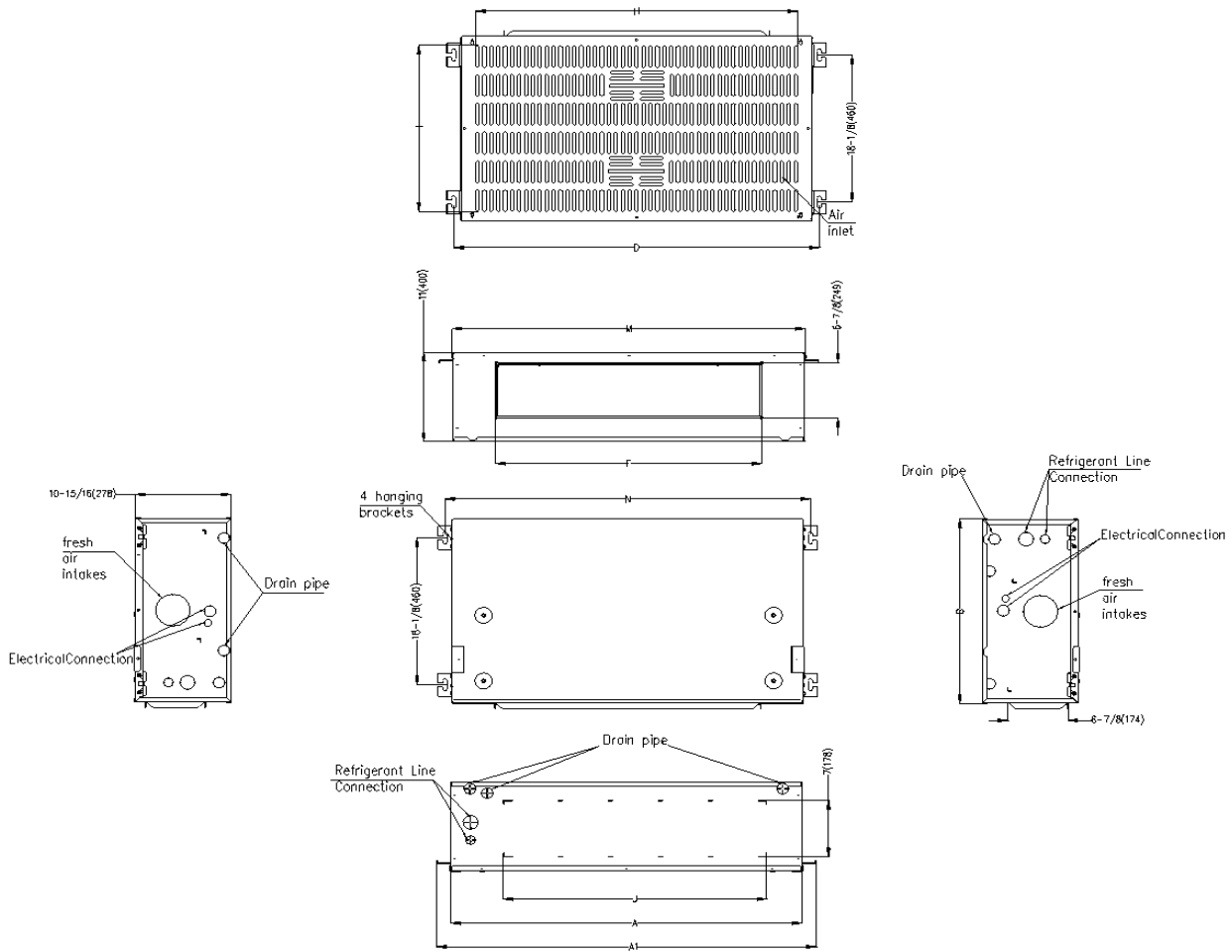

	18K		24K		30K		36K	
	inch	mm	inch	mm	inch	mm	inch	mm
A	39-15/16	1015	45-7/8	1165	51-15/16	1320	58-7/8	1495
A1	43-1/4	1098	49-1/8	1248	55-1/4	1403	62-1/8	1578
J	30	761	35-7/8	911	41-15/16	1066	48-7/8	1241
D	41-5/8	1057	47-1/2	1207	53-5/8	1362	60-1/2	1537
F	30-1/4	769	36-3/16	919	42-5/16	1074	49-3/16	1249
H	36-5/8	930	39-3/4	1010	47-5/8	1210	53-15/16	1370
M	40-3/16	1020	46-1/16	1170	52-3/16	1325	59-1/16	1500
N	41-5/8	1057	40-7/16	1027	53-5/8	1362	60 1/2	1537

Outdoor Unit Dimension

Unit:inch(mm)

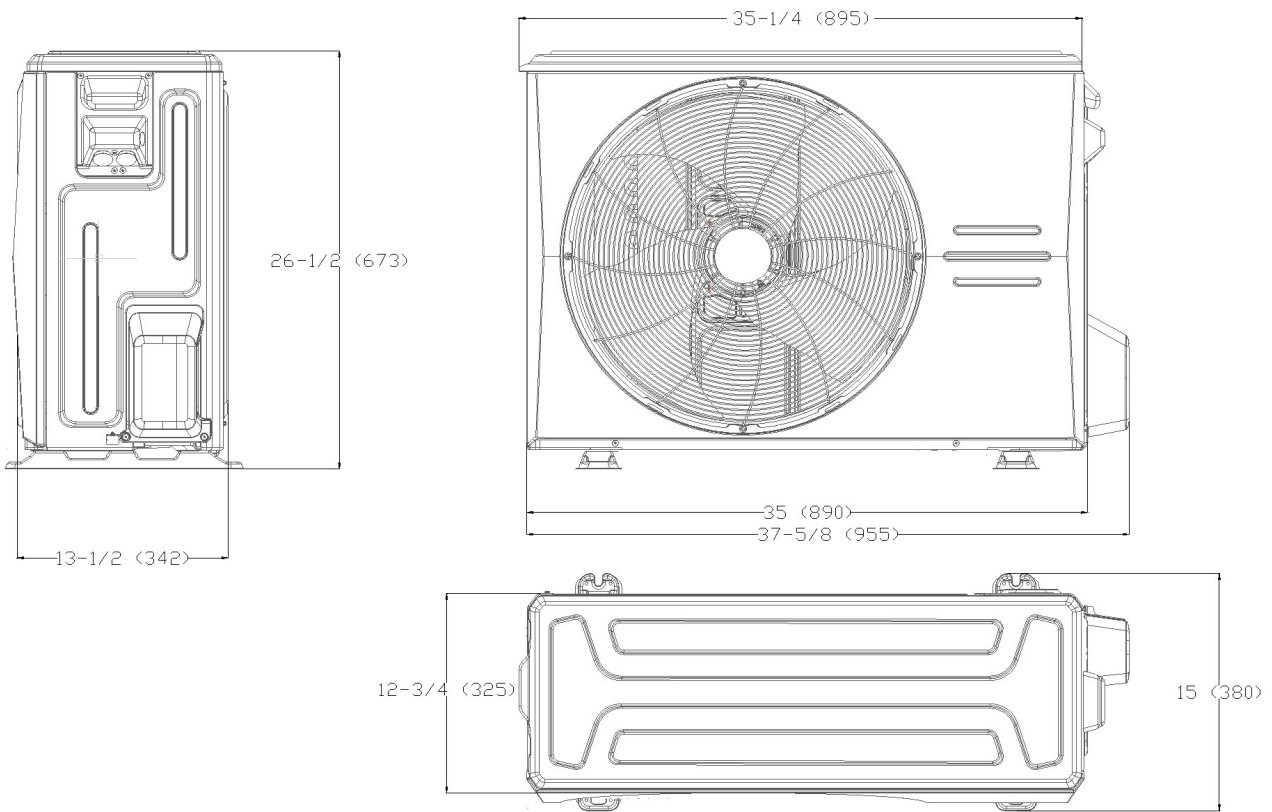

Installation Instruction For Outdoor Unit

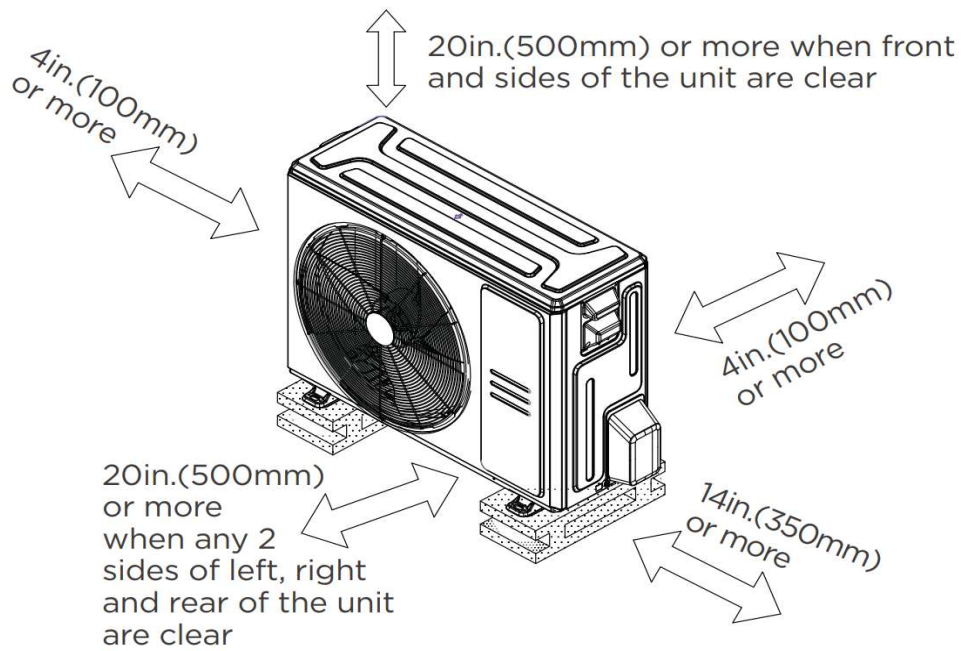

Fan Performance For Indoor Unit

18K

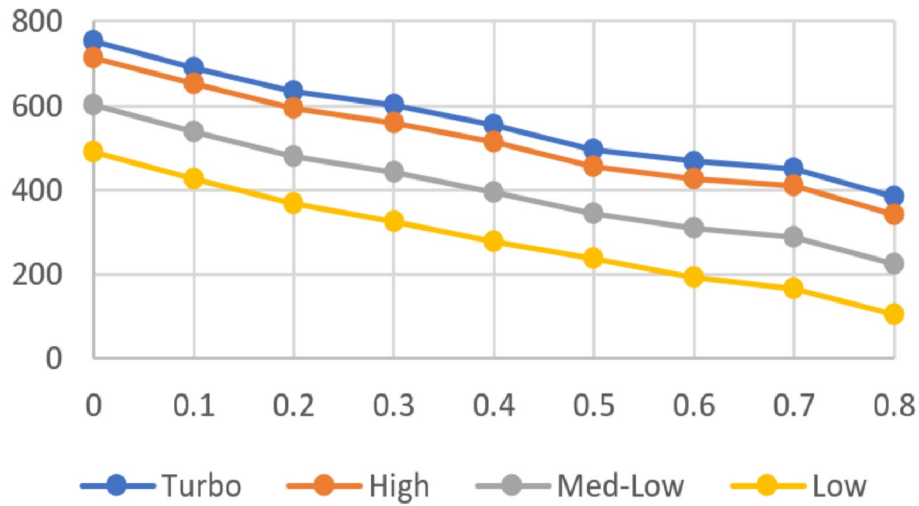

Features

- High efficiency up to 16.8 SEER2, 11.5 EER2, 8.8 HSPF2
- Aluminum Coil
- IDU compatible with 115V and 230V
- Constantly Air Flow system up to 0.80 In.W.G
- Optional Auxiliary heat kit up to 10kW
- Easy Maintenance
- Multiple control options available:
 - Two way communication wired controller:120N(X6)
 - Two way communication wired controller with built-in WiFi:120N(X6W)
 - Wireless remote controller
 - Third-Party 24V Thermostat
- Adaptive Control wiring method on 24V and RS485
- Downward or Backward (optional) air inlet
- Chassis heater and crankcase heater equipped as standard

North American HVAC Products Ltd.

Add.: #100 5118 N Fraser Wy, Burnaby, BC V5J 0H1

Tel: 604-430-8496 info@nahvac.com www.nahvac.com

Midea reserves the right to change the specifications of the product, and to withdraw or replace products without prior notification or public announcement.
Midea is constantly developing and improving its products.