

R454b Refrigerant

SUBMITTAL DATA SHEET



Series Name: Extreme Heat AHU Series
Model Number: MAUHE-H24B-2A/MO1HE-H24B-2A

Air Handler Heat Pump System

Location:	Approval:
Engineer:	Date:
Submitted to:	Construction:
Submitted by:	Unit #:
Reference:	Drawing #:



INDOOR SPECIFICATION

ESP(in.W.G)	0-0.8	
Indoor Noise Level (Turbo/H/M/L/Si) (dBA)	44 / 44 / 42 / 28 / 28	
Dimension (W×D×H)	inch	17-1/2 x 21 x 45
	mm	445 × 534 × 1143
Package (W×D×H)	inch	26-1/2 x 20-7/8 x 48-5/8
	mm	675 × 530 × 1235
Net/Gross Weight	lbs	106 /127
	kg	47.9 / 57.8

OUTDOOR SPECIFICATION

Compressor Type	ROTARY	
Compressor Model	KTM240D46UKT2	
Refrigerant	R454B	
Refrigerant Oil Charge(mL)	620	
Refrigerant Oil	VG74	
Outdoor Air Flow (Max) (CFM)	1,766	
Outdoor Noise Level (dBA)	60	
Dimension (W×D×H)	inch	35 x 13-1/2 x 26-1/2
	mm	890 × 342 × 673
Package (W×D×H)	inch	39-1/8 x 15-5/8 x 29-1/8
	mm	995 × 398 × 740
Net/Gross Weight	lbs	102 /109
	kg	46.4 / 49.5

EFFICIENCY

Cooling		Heating	
SEER2	18.3	HSPF2-4	10.0
EER2	11.7	COP	3.33

PERFORMANCE of Cooling

Cooling (Btu/hr)	
Rated Capacity	23,000
Min/Max Capacity	7,200 ~ 2,7000
Moisture Removal(L/h)	2.05
Standard Operating Range(°F/°C)	-22~122 (-30 ~ 50)
Rated Cooling Conditions:	Indoor: 80°F DB/67°F WB Outdoor: 95°F DB/75°F WB

PERFORMANCE of Heating

Heating (Btu/hr)	
1. @ 47°F Rated	24,000
2. @ 47°F Min/Max Capacity	7,100 ~ 30,000
3. @ 17°F Rated	20,000
4. @ 5°F Rated: Capacity / COP	21,600 / 1.87
5. @ 5°F Max: Capacity	21,600
Standard Operating Range(°F/°C)	-22~75 (-30 ~ 24)
1. Rated Heating Conditions:	Indoor: 70°F DB/60°F WB Outdoor: 47°F DB/43°F WB
2. Rated Heating Conditions:	Indoor: 70°F DB/60°F WB Outdoor: 17°F DB/15°F WB
3. Heating Conditions, Compressor Operating at Max. Frequency	Indoor: 70°F DB/60°F WB Outdoor: 5°F DB/5°F WB

ELECTRICAL

Indoor Power Supply	115/208/230V,60Hz,1Ph
Indoor MCA 115V/(208/230V)	5.5/4.0
Indoor MOP	15.0
Outdoor Power Supply	208/230V,60Hz,1Ph
Outdoor MCA	19.0
Outdoor MOP	20.0
Communication Wiring	AWG 20/2
Compressor RLA	14.0
Outdoor Fan Motor RLA	1.0
Outdoor Fan Motor W	80
Indoor Fan Motor RLA	3.0
Indoor Fan Motor W	250
System Power Input @ Cooling (W)	1,965 (530 ~ 2,870)
System Power Input @ Heating (W)	2,112 (440 ~ 2,730)
MCA: Min. circuit amps (A)	MOCP: Max. over current protection (A)
RLA: Rated load amps (A)	W: Fan motor rated output (W)

PIPING

Throttle type(Indoor)	EXV
Throttle type(Outdoor)	EXV
Liquid Size	3/8" (9.52mm)
Gas Size	3/4" (19mm)
Max. Piping Length(ft/m)	164 (50)
Max. Height Difference(ft/m)	82 (25)
Max. Pre-charged Length(ft/m)	25 (7.5)
Refrigerant Pre-charged Amount(oz/kg)	74 (2.1)
Additional Charge of Refrigerant(oz/ft)/(g/m)	0.7 (65)
Connection Method	Flared

Indoor Unit Dimension

Unit:inch(mm)

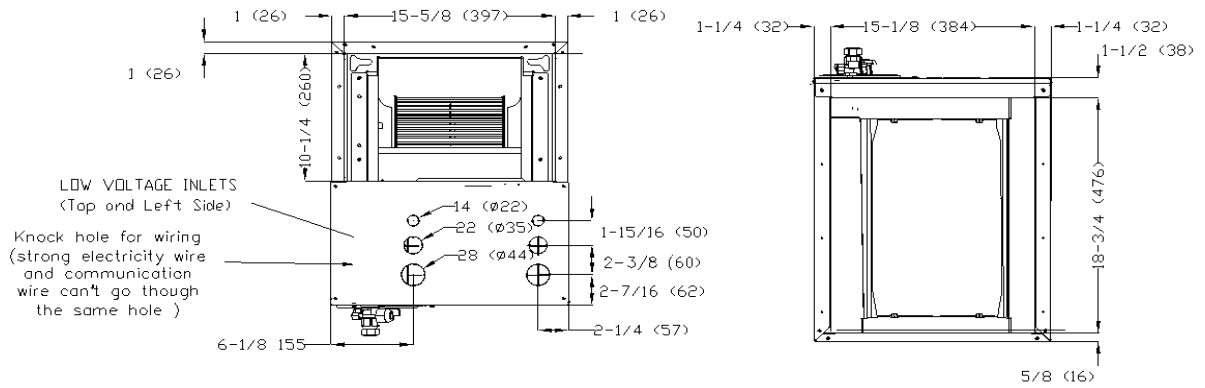
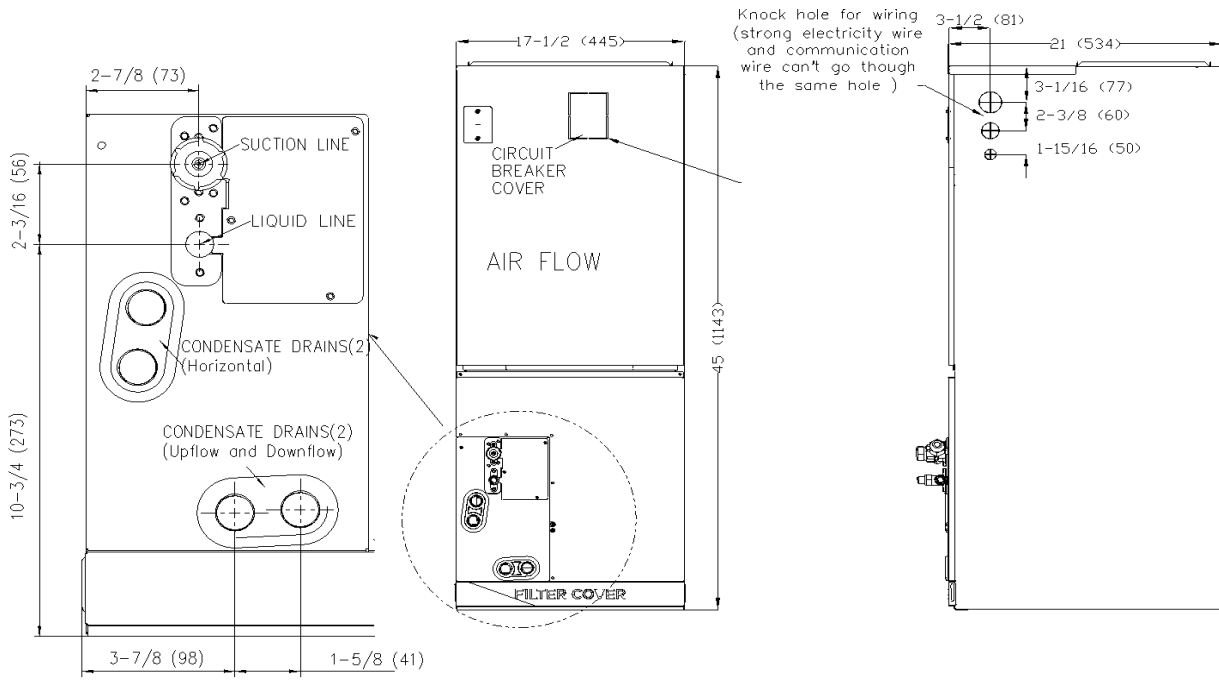

Outdoor Unit Dimension

Unit:inch(mm)

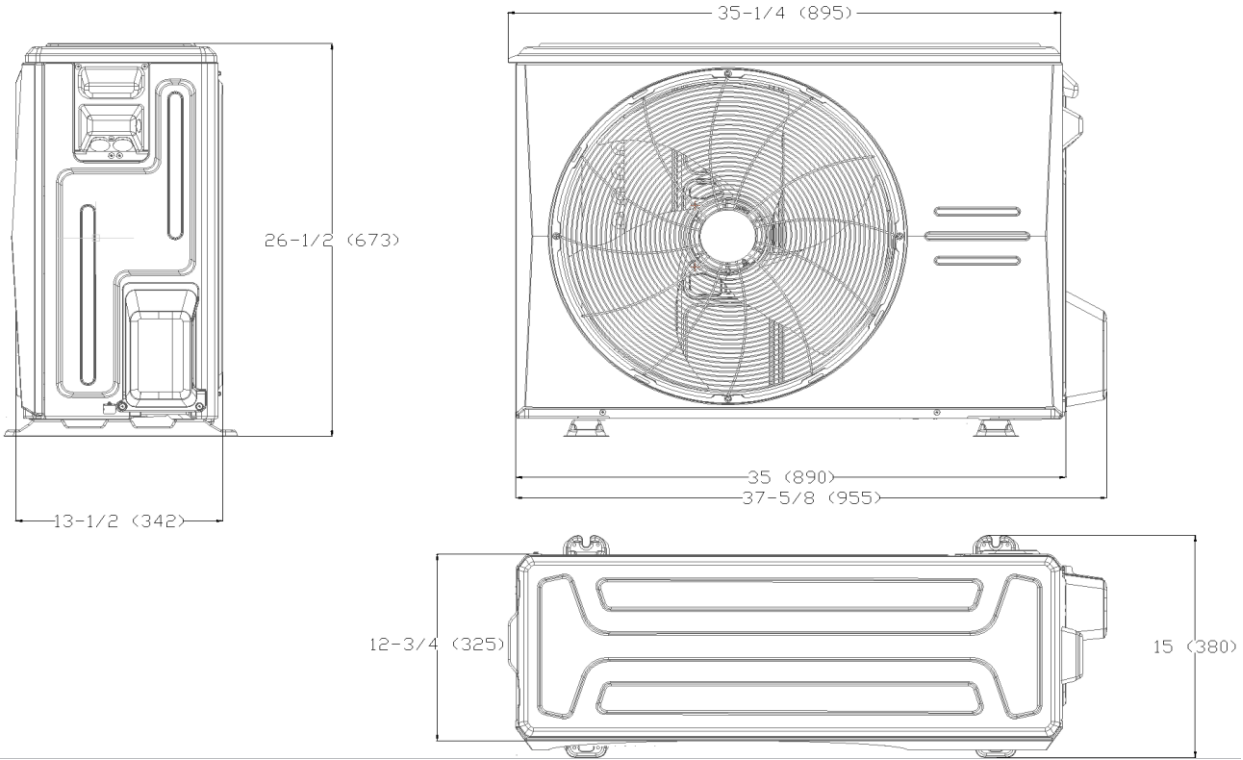

Installation Instruction For Outdoor Unit

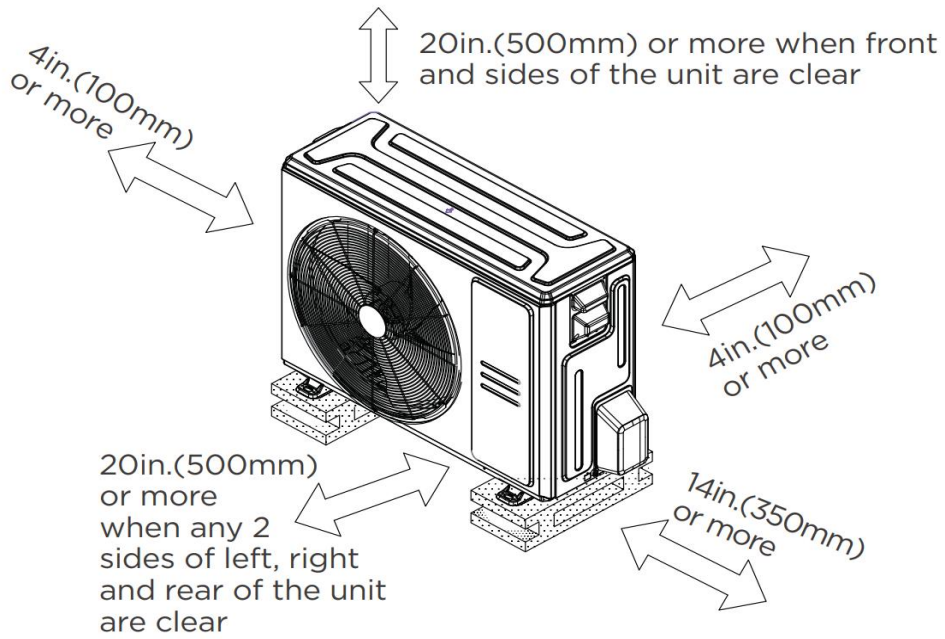

Fan Performance For Indoor Unit

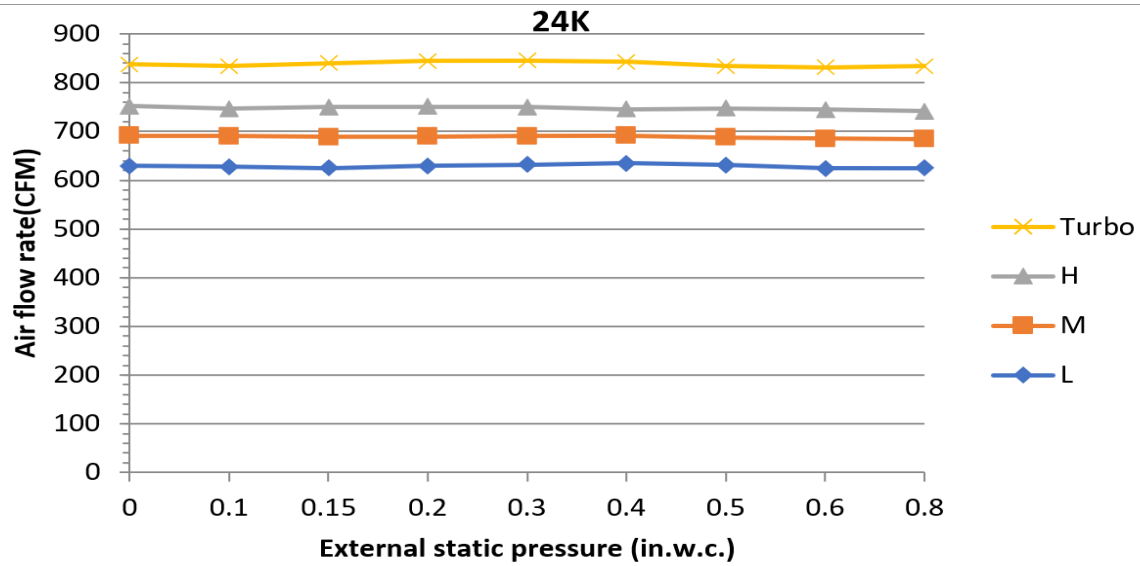

Features

- Multi-position installation: horizontal(left or right), vertical(up or down)
- Aluminum Coil
- Constantly Air Flow system up to 0.80 In.W.G
- 1 inch R4.2 fiberglass free insulation reduces condensation and boosts efficiency(optional)
- Optional Auxiliary heat kit up to 25kW
- Easy Maintenance
- Multiple control options available:
 - Two way communication wired controller:120N(X6)
 - Two way communication wired controller with built-in WiFi:120N(X6W)
 - Wireless remote controller
 - Third-Party 24V Thermostat
- Adaptive Control System
- High efficiency up to 19 SEER2, 12.5 EER2, 10.3 HSPF2
- 100% heat output at -4F*
- Chassis heater and crankcase heater equipped as standard

* For 36K model, rated cooling capacity/heating capacity at -4F=100%

North American HVAC Products Ltd.

Add.: #100 5118 N Fraser Wy, Burnaby, BC V5J 0H1

Tel: 604-430-8496 info@nahvac.com www.nahvac.com

Midea reserves the right to change the specifications of the product, and to withdraw or replace products without prior notification or public announcement.
Midea is constantly developing and improving its products.