

R454b Refrigerant

SUBMITTAL DATA SHEET



Series Name: Regular Heat AHU Series
Model Number: MAUHE-H36B-2A/MO1BE-H36B-2A

Air Handler Heat Pump System

Location:	Approval:
Engineer:	Date:
Submitted to:	Construction:
Submitted by:	Unit #:
Reference:	Drawing #:



INDOOR SPECIFICATION

Indoor Air Flow (Turbo/H/M/L/Si) (CFM)	1189 / 1083 / 971 / 865 / 865
Indoor Noise Level (Turbo/H/M/L/Si) (dBA)	48 / 48 / 45 / 28 / 28
Dimension (WxDxH)	inch 21 x 21 x 49
	mm 534 x 534 x 1245
Package (WxDxH)	inch 26-9/16 x 24-7/16 x 52-9/16
	mm 675 x 620 x 1335
Net/Gross Weight	lbs 129 /154
	kg 58.7 / 69.8

OUTDOOR SPECIFICATION

Compressor Type	ROTARY
Compressor Model	KTF310D43UMT
Refrigerant	R454B
Refrigerant Oil Charge(mL)	1,000
Refrigerant Oil	VG74
Outdoor Air Flow (Max) (CFM)	2,413
Outdoor Noise Level (dBA)	63
Dimension (WxDxH)	inch 37-1/4 x 16-1/8 x 31-7/8
	mm 946 x 410 x 810
Package (WxDxH)	inch 42-7/8 x 19-5/8 x 34-7/8
	mm 1090 x 500 x 885
Net/Gross Weight	lbs 153 /164
	kg 69.5 / 74.2

EFFICIENCY

Cooling		Heating	
SEER2	16.1	HSPF2-4	8.7
EER2	10.0	COP	3.40

PERFORMANCE of Cooling

Cooling (Btu/hr)	
Rated Capacity	36,000
Min/Max Capacity	8,300 ~ 38,900
Moisture Removal(L/h)	3.62
Standard Operating Range(*F/*C)	-13~122 (-25 ~ 50)
Rated Cooling Conditions:	Indoor: 80°F DB/67°F WB Outdoor: 95°F DB/75°F WB

PERFORMANCE of Heating

Heating (Btu/hr)	
1. @ 47°F Rated	36,000
2. @ 47°F Min/Max Capacity	6,700 ~ 41,300
3. @ 17°F Rated	25,600
4. @ 5°F Rated: Capacity / COP	27,000/2
5. @ 5°F Max: Capacity	27,000
Standard Operating Range(*F/*C)	-13~75 (-25 ~ 24)
1. Rated Heating Conditions:	Indoor: 70°F DB/60°F WB Outdoor: 47°F DB/43°F WB
2. Rated Heating Conditions:	Indoor: 70°F DB/60°F WB Outdoor: 17°F DB/15°F WB
3. Heating Conditions, Compressor Operating at Max. Frequency	Indoor: 70°F DB/60°F WB Outdoor: 5°F DB/5°F WB

ELECTRICAL

Indoor Power Supply	115/208/230V,60Hz,1Ph
Indoor MCA 115V/(208/230V)	8.0/6.0
Indoor MOP	15.0
Outdoor Power Supply	208/230V,60Hz,1Ph
Outdoor MCA	24.0
Outdoor MOP	30.0
Communication Wiring	AWG 20/2
Compressor RLA	17.5
Outdoor Fan Motor RLA	1.5
Outdoor Fan Motor W	120
Indoor Fan Motor RLA	4.5
Indoor Fan Motor W	375
System Power Input @ Cooling (W)	3,600 (710 ~ 4,500)
System Power Input @ Heating (W)	3,100 (460 ~3,550)
MCA: Min. circuit amps (A)	MOCOP: Max. over current protection (A)
RLA: Rated load amps (A)	W: Fan motor rated output (W)

PIPING

Throttle type(Indoor)	EXV
Throttle type(Outdoor)	EXV
Liquid Size	3/8" (9.52mm)
Gas Size	3/4" (19mm)
Max. Piping Length(ft/m)	246 (75)
Max. Height Difference(ft/m)	98 (30)
Max. Pre-charged Length(ft/m)	25 (7.5)
Refrigerant Pre-charged Amount(oz/kg)	116 (3.3)
Additional Charge of Refrigerant(oz/ft)/(g/m)	0.7 (65)
Connection Method	Flared

Indoor Unit Dimension

Unit:inch(mm)

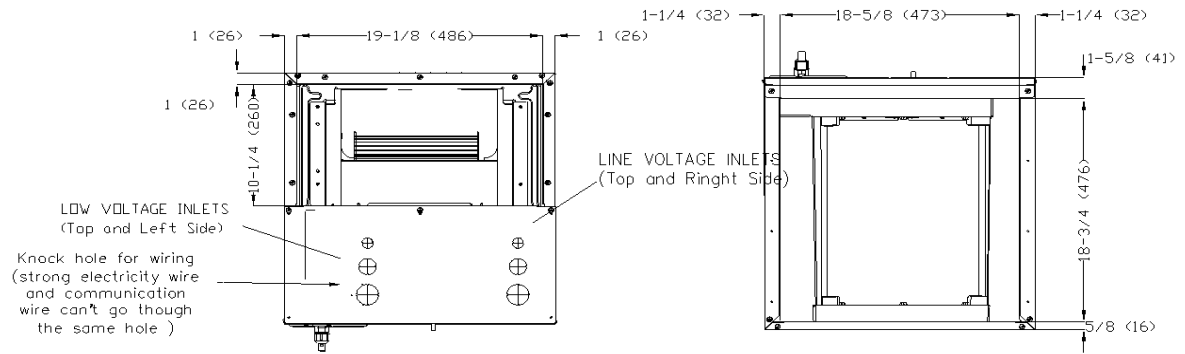
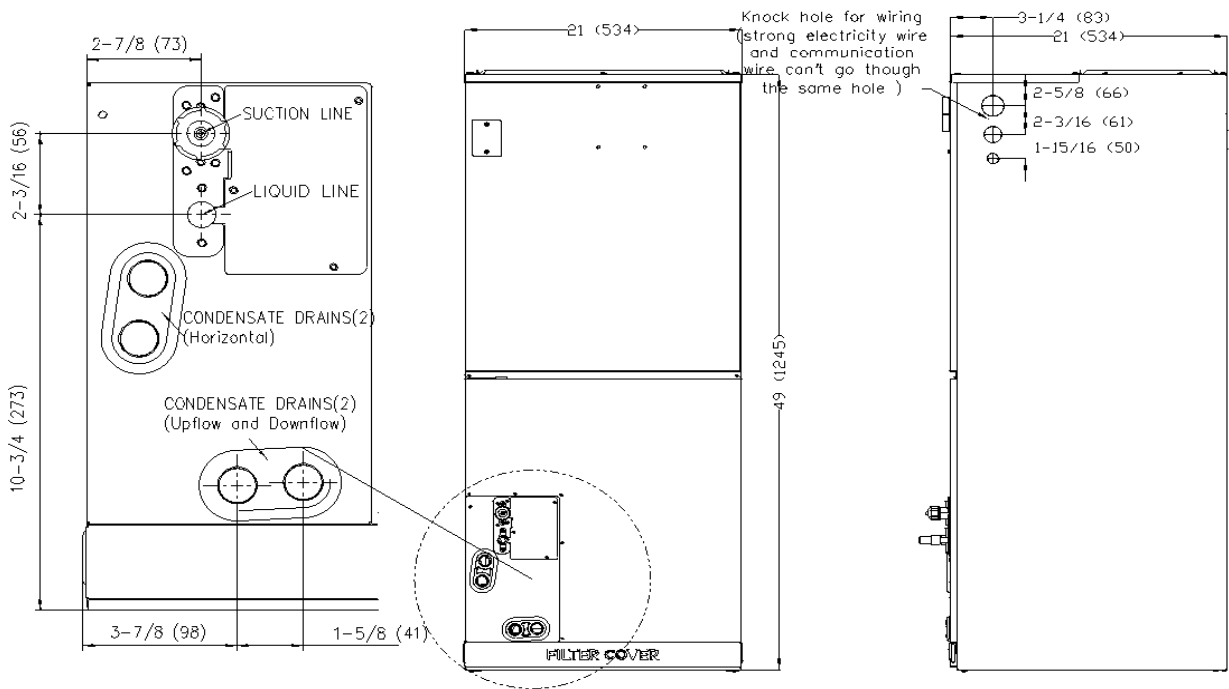

Outdoor Unit Dimension

Unit:inch(mm)

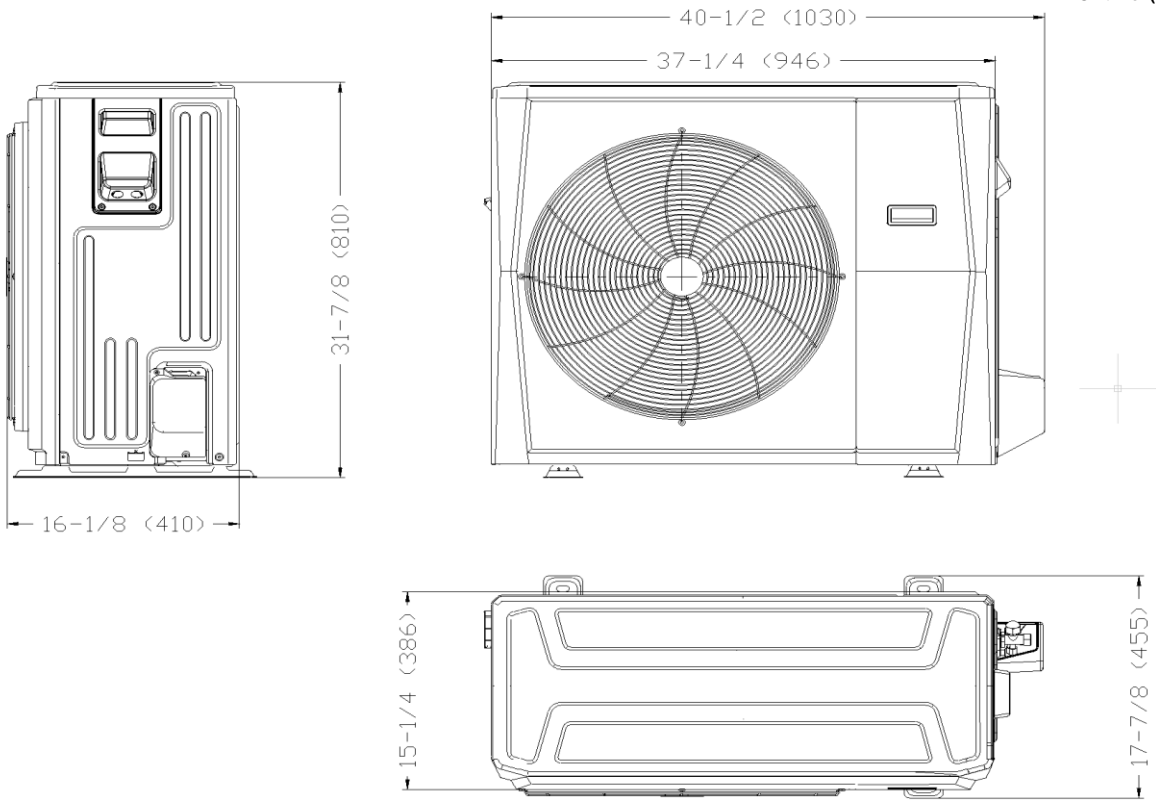

Installation Instruction For Outdoor Unit

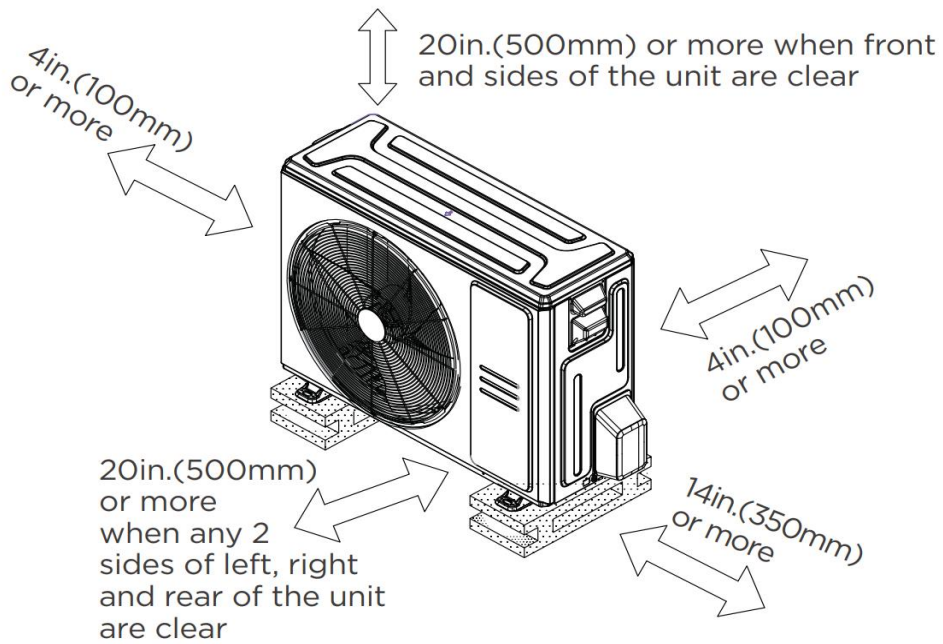

Fan Performance For Indoor Unit

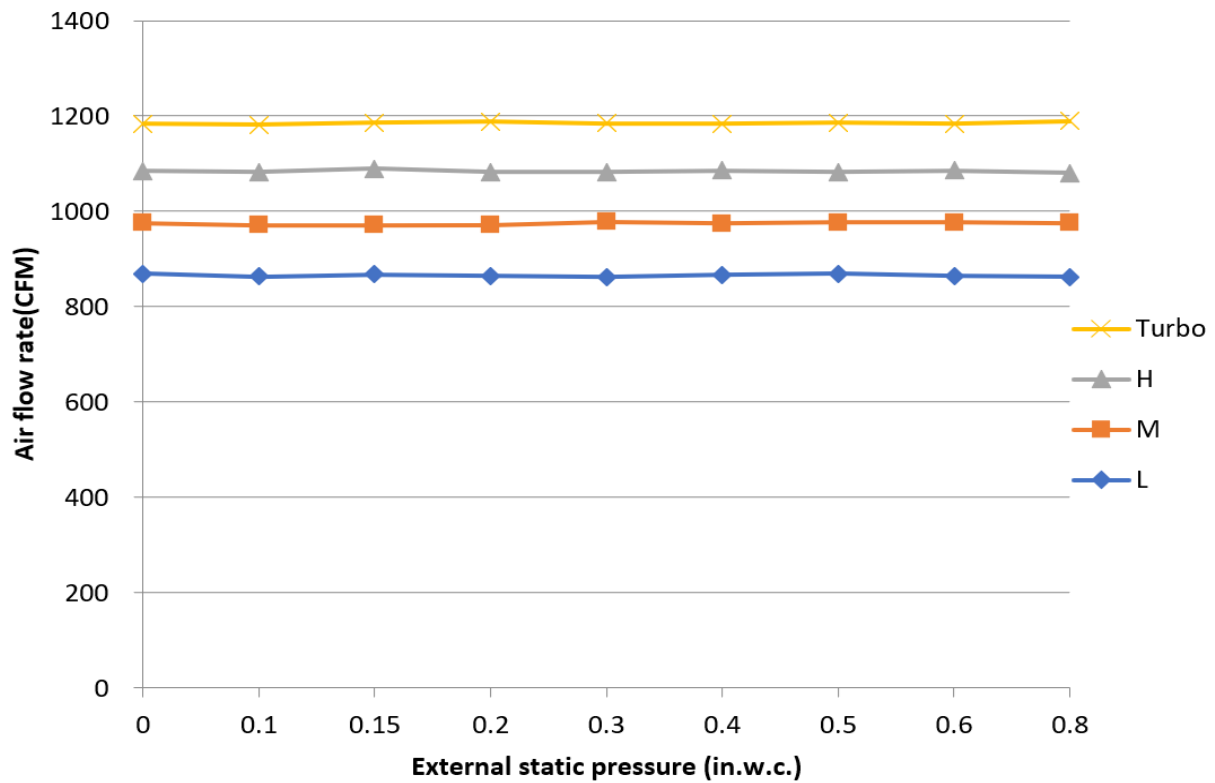

Features

- Multi-position installation: horizontal(left or right), vertical(up or down)
- Aluminum Coil
- Constantly Air Flow system up to 0.80 In.W.G
- 1 inch R4.2 fiberglass free insulation reduces condensation and boosts efficiency(optional)
- Optional Auxiliary heat kit up to 25kW
- Easy Maintenance
- Multiple control options available:
 - Two way communication wired controller:120N(X6)
 - Two way communication wired controller with built-in WiFi:120N(X6W)
 - Wireless remote controller
 - Third-Party 24V Thermostat
- Adaptive Control System
- High efficiency up to 18.8 SEER2, 11 EER2, 9.7 HSPF2
- Chassis heater and crankcase heater equipped as standard

North American HVAC Products Ltd.

Add.: #100 5118 N Fraser Wy, Burnaby, BC V5J 0H1

Tel: 604-430-8496 info@nahvac.com www.nahvac.com

Midea reserves the right to change the specifications of the product, and to withdraw or replace products without prior notification or public announcement.
Midea is constantly developing and improving its products.