

# R454b Refrigerant

# SUBMITTAL DATA SHEET



Series Name: EVOX G<sup>3</sup> Modular Air Handler Extreme Heat Series  
Model Number: MAUSE-H30B-2A/MO1HE-H30B-2A

## Air Handler Heat Pump System

Location:	Approval:
Engineer:	Date:
Submitted to:	Construction:
Submitted by:	Unit #:
Reference:	Drawing #:



## INDOOR SPECIFICATION

ESP (in.W.C.)	0~1.0	
Indoor Air Flow (Turbo/H/ML/SI) (CFM)	989 / 895 / 806 / 712 / 712	
Indoor Noise Level (Turbo/H/ML/SI) (dBA)	49 / 47 / 45.5 / 31.5 / 31.5	
Dimension (W×D×H)	inch	17-1/2 x 21-1/2 x 58-1/8
	mm	445 x 546 x 1476
Package (W×D×H)	inch	20-1/2 x 31-1/8 x 62-3/8
	mm	520 x 790 x 1585
Net/Gross Weight	lbs	149 / 182
	kg	67.7 / 82.6

## OUTDOOR SPECIFICATION

Compressor Type	TWIN-ROTARY	
Compressor Model	MTH356UKRC8FQL	
Refrigerant	R454B	
Refrigerant Oil Charge(mL)	1,300	
Refrigerant Oil	HAF68D1A	
Outdoor Air Flow (Max) (CFM)	3,002	
Dimension (W×D×H)	inch	37-1/4 x 16-1/8 x 31-7/8
	mm	946 x 410 x 810
Package (W×D×H)	inch	42-7/8 x 19-5/8 x 34-7/8
	mm	1,090 x 500 x 885
Net/Gross Weight	lbs	167 / 176
	kg	75.6 / 80.0

## EFFICIENCY

Cooling		Heating	
SEER2	17.2	HSPF2-4	10.8
EER2	12.0	COP	3.54

## PERFORMANCE of Cooling

Cooling (Btu/hr)	
Rated Capacity	30,000
Min/Max Capacity	11,200 ~ 40,000
Moisture Removal(L/h)	3.15
Standard Operating Range(*F/*C)	-22~122 (-30 ~ 50)
Rated Cooling Conditions:	Indoor: 80°F DB/67°F WB Outdoor: 95°F DB/75°F WB

## PERFORMANCE of Heating

Heating (Btu/hr)	
1. @ 47°F Rated	33,000
2. @ 47°F Min/Max Capacity	9,700 ~ 35,800
3. @ 17°F Rated	24,000
4. @ 5°F Rated: Capacity / COP	33,200 / 1.97
5. @ 5°F Max: Capacity	33,200
Standard Operating Range(*F/*C)	-22~75 (-30 ~ 24)
1. Rated Heating Conditions:	Indoor: 70°F DB/60°F WB Outdoor: 47°F DB/43°F WB
2. Rated Heating Conditions:	Indoor: 70°F DB/60°F WB Outdoor: 17°F DB/15°F WB
3. Heating Conditions, Compressor Operating at Max. Frequency	Indoor: 70°F DB/60°F WB Outdoor: 5°F DB/5°F WB

## ELECTRICAL

Indoor Power Supply	115/208/230V,60Hz,1Ph
Indoor MCA 115V/(208/230V)	8.0/6.0
Indoor MOP	15.0
Outdoor Power Supply	208/230V,60Hz,1Ph
Outdoor MCA	29.5
Outdoor MOP	30.0
Communication Wiring	AWG 20/2
Compressor RLA	18.0
Outdoor Fan Motor RLA	1.0
Outdoor Fan Motor W	120
Indoor Fan Motor RLA	4.5
Indoor Fan Motor W	600
System Power Input @ Cooling (W)	2,500 (1,020 ~ 3,880)
System Power Input @ Heating (W)	2,730 (580 ~ 3,030)
MCA: Min. circuit amps (A)	MOCOP: Max. over current protection (A)
RLA: Rated load amps (A)	W: Fan motor rated output (W)

## PIPING

Throttle type(Indoor)	EXV
Throttle type(Outdoor)	EXV
Liquid Size	3/8" (9.52mm)
Gas Size	3/4" (19mm)
Max. Piping Length(ft/m)	164 (50)
Max. Height Difference(ft/m)	82 (25)
Max. Pre-charged Length(ft/m)	25 (7.5)
Refrigerant Pre-charged Amount(oz/kg)*	106 (3)
Additional Charge of Refrigerant(oz/ft)/(g/m)	0.7 (65)
Connection Method	Flared

\* When MO1HE-H30B-2A is paired with MAUSE-H30B-2A, an additional 0.6kg/21.16oz of refrigerant is required.

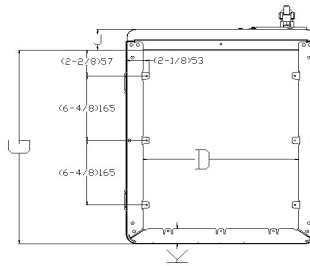
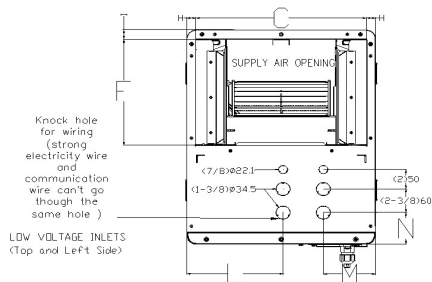
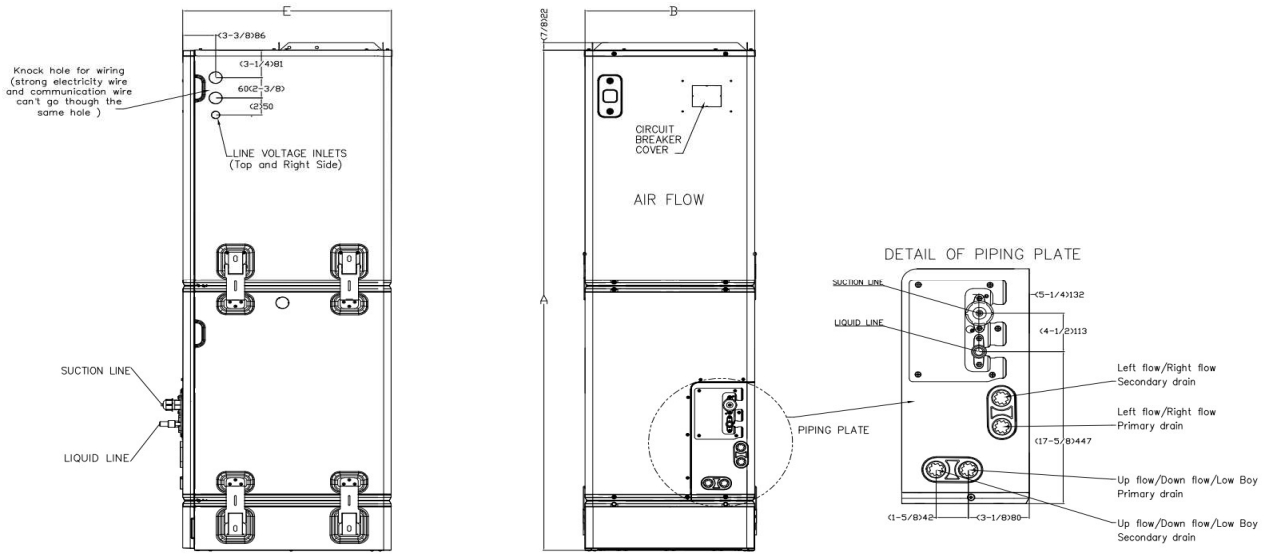

Dimensions	Model(Btu/h)	18K/24K		30K/36K		48K/54K	
		inch	mm	inch	mm	inch	mm
A	Model Height	53-7/8	1368	58-1/8	1476	60-1/8	1526
B	Model Width	14-4/8	368	17-4/8	445	21-4/8	546
C	Supply Air Opening Width	12-7/8	328	16	405	19-7/8	506
D	Return Air Opening Width	11-1/8	282	14-4/8	368	18-4/8	470
E	Model Depth	21-1/2	546	21-1/2	546	21-1/2	546
F	Supply Air Opening Depth	10-5/8	271	10-5/8	271	10-5/8	271
G	Return Air Opening Depth	19	484	19	484	19	484
H	Supply Air Opening Clearance	7/8	22	7/8	22	7/8	22
I	Supply Air Opening Clearance	1	24	1	24	1	24
J	Return Air Opening Front Clearance	2-4/8	62	2-4/8	62	2-4/8	62
K	Return Air Opening Back Clearance	1-4/8	37	1-4/8	37	1-4/8	37
L	Top cover knock hole	/	/	9	229	10-7/8	275
M	Top cover knock hole	4-1/2	113	4-7/8	124	5-1/8	131
N	Top cover knock hole	2	51	2	51	1-5/8	41

Outdoor Unit Dimension

Unit: inch (mm)

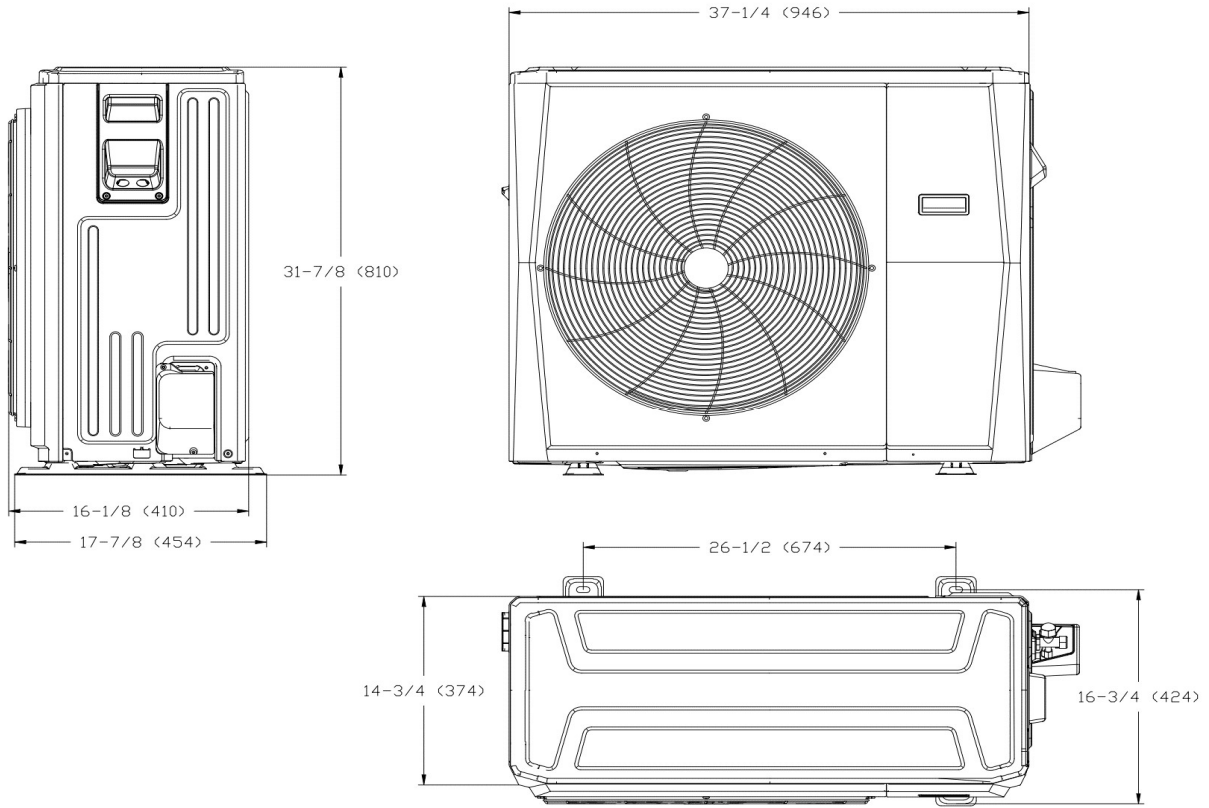

Installation Instruction For Outdoor Unit

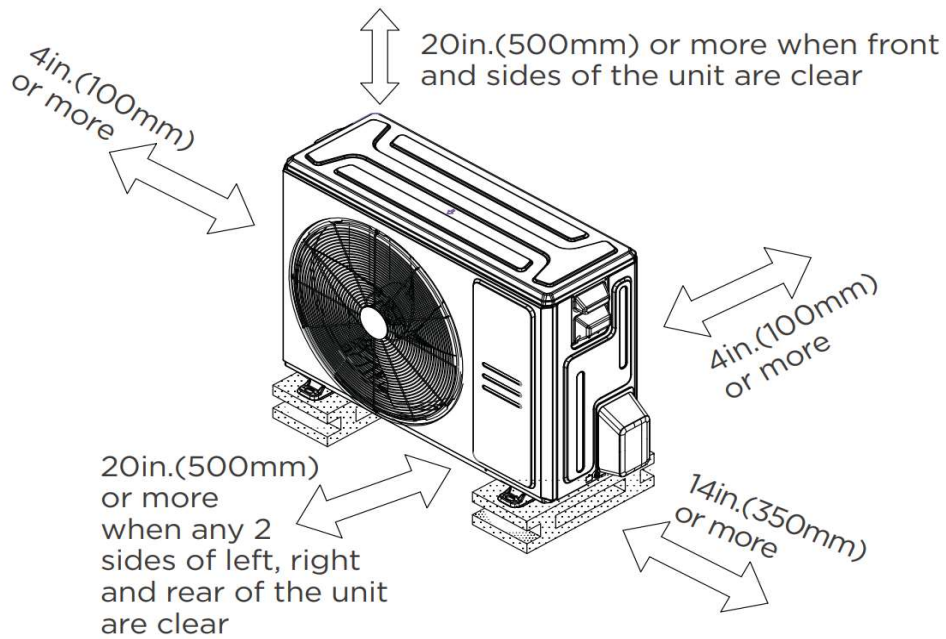

Fan Performance For Indoor Unit

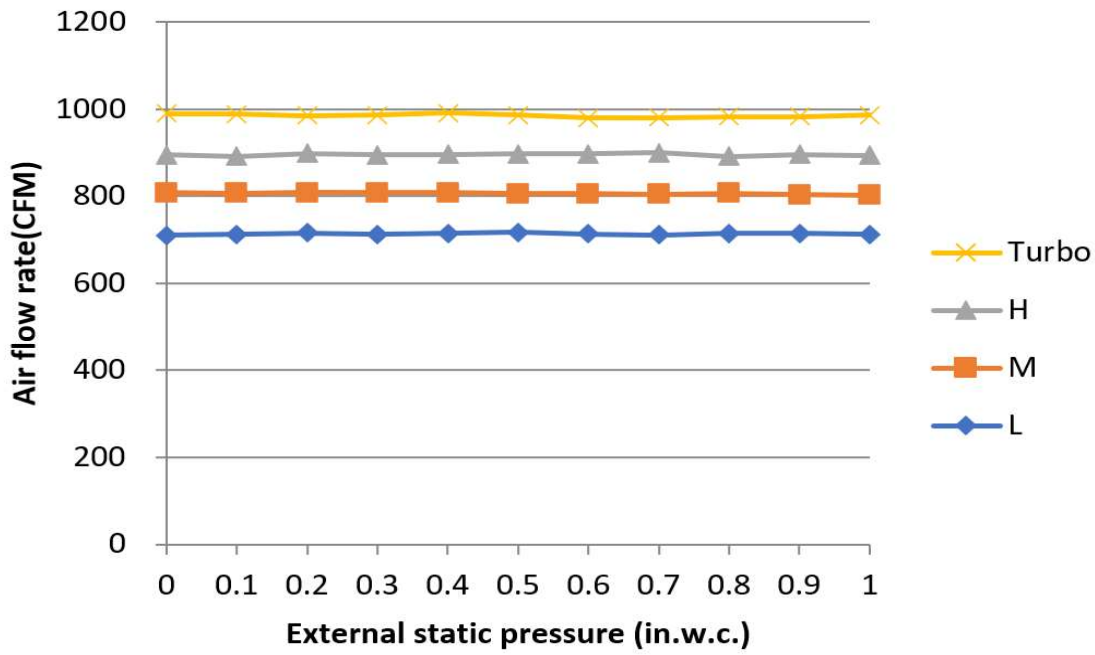

Outdoor Unit Sound Pressure Data

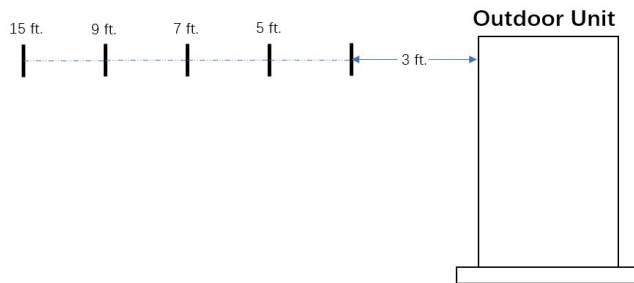

Model	Maximum Sound Pressure (dBA)				
	3'	5'	7'	9'	15'
MO1HE-H18B-2A	54.7	52.8	51.5	50.6	48.7
MO1HE-H24B-2A	55.9	54.0	52.7	51.8	49.9
MO1HE-H30B-2A	59.9	58.0	56.7	55.8	53.9
MO1HE-H36B-2A	60.2	58.3	57.0	56.1	54.2
MO1SE-H36B-2A	59.3	57.5	56.3	55.4	53.5
MO1HE-H48B-2A	60.9	59.0	57.7	56.8	54.9
MO1HE-H60B-2A	62.1	60.2	58.9	58.0	56.1

## Features

- Multi-position installation: horizontal(left or right), vertical( up or down)
- The IDU supports 115/230V voltage compatibility
- Aluminum Coil
- Constant Air Flow system: Up to 1.0 In.W.C.
- Optional Auxiliary heat kit up to 25kW
- Easy Maintenance
- Multiple control options available:
  - Wireless remote controller RG10 (Built-In)
  - Two-way communication programmable wired controller with built-in Wi-Fi:120N(X6W)
  - Midea Smart Thermostat
  - Third-Party 24V Thermostat
- Adaptive Control System
- 100% heating output down to -13°F\*
- Standard graphene fins, a standard feature of the outdoor unit, deliver superior corrosion resistance
- The outdoor unit comes standard with chassis and crankshaft electric heating
- Built-in Refrigerant Detection Sensor

\* When MAUSE-H36B-2A is paired with MO1SE-H36B-2A, its rated heating capacity at -13°F is 100%