

R454b Refrigerant

SUBMITTAL DATA SHEET



Series Name: One Way Cassette Energy Star Series
 Model Number: MCAHU-H12B-2A/MO1ES-H12B-2A

One Way Cassette Heat Pump System

Location:	Approval:
Engineer:	Date:
Submitted to:	Construction:
Submitted by:	Unit #:
Reference:	Drawing #:



INDOOR SPECIFICATION

Indoor Air Flow (Turbo/H/M/L/Si) (CFM)	353 / 312 / 283 / 247 / 177	
Indoor Noise Level (Turbo/H/M/L/Si) (dBA)	43 / 43 / 37.5 / 26 / 22	
Dimension (WxDxH)	inch	50-1/4 x 13-1/4 x 9
	mm	1278 x 335 x 228
Package (WxDxH)	inch	57-5/8 x 22-1/2 x 22-5/8
	mm	1463 x 571 x 575
Net/Gross Weight	lbs	45 / 82
	kg	20.5 / 37.4

OUTDOOR SPECIFICATION

Compressor Type	ROTARY	
Compressor Model	KSK103D33UEZ3	
Refrigerant	R454B	
Refrigerant Oil Charge(mL)	310	
Refrigerant Oil	VG74	
Outdoor Air Flow (Max) (CFM)	1,236	
Outdoor Noise Level (dBA)	54.5	
Dimension (WxDxH)	inch	30-1/8 x 11-7/8 x 21-7/8
	mm	765 x 303 x 555
Package (WxDxH)	inch	34-7/8 x 13-1/4 x 24
	mm	887 x 337 x 610
Net/Gross Weight	lbs	62 / 68
	kg	28.2 / 30.7

EFFICIENCY

Cooling		Heating	
SEER2	22.1	HSPF2-4	10.0
EER2	12.3	COP	3.40

PERFORMANCE of Cooling

Cooling (Btu/hr)	
Rated Capacity	12,000
Min/Max Capacity	3,900-13,800
Moisture Removal(L/h)	1.54
Standard Operating Range(°F/°C)	-13~122 (-25~50)
Conditions:	Indoor: 80°F DB/67°F WB Outdoor: 95°F DB/75°F WB

PERFORMANCE of Heating

Heating (Btu/hr)	
1. @ 47°F Rated	12,000
1. @ 47°F Min/Max Capacity	4,700-15,300
2. @ 17°F Rated	8,600
3. @ 5°F Rated: Capacity / COP	8,600 / 2.48
3. @ 5°F Max: Capacity	8,600
Standard Operating Range(°F/°C)	-13~75 (-25~24)
1. Conditions:	Indoor: 70°F DB/60°F WB Outdoor: 47°F DB/43°F WB
2. Conditions:	Indoor: 70°F DB/60°F WB Outdoor: 17°F DB/15°F WB
3. Conditions:	Indoor: 70°F DB/60°F WB Outdoor: 5°F DB/5°F WB

ELECTRICAL

Power Supply	208 / 230 V,60 Hz,1 Ph	
System MCA	12.0	
Connection Wiring	AWG 14/4	
System MOCP	15.0	
Compressor RLA	7.3	
Outdoor Fan Motor RLA	0.6	
Outdoor Fan Motor W	34	
Indoor Fan Motor RLA	1	
Indoor Fan Motor W	30	
System Power Input @ Cooling (W)	976 (220~1,180)	
System Power Input @ Heating (W)	1,034 (275~1,310)	
MCA: Min. circuit amps (A)	MOCP: Max. over current protection (A)	
RLA: Rated load amps (A)	W: Fan motor rated output (W)	

PIPING

Throttle type(Indoor)	N/A	
Throttle type(Outdoor)	EXV	
Liquid Size	1/4" (6.35 mm)	
Gas Size	3/8" (9.52 mm)	
Max. Piping Length(ft/m)	82 (25)	
Max. Height Difference(ft/m)	49 (15)	
Max. Pre-charged Length(ft/m)	25 (7.5)	
Refrigerant Pre-charged Amount(oz/kg)	32 (0.92)	
Additional Charge of Refrigerant(oz/ft)/(g/m)	0.16 (15)	
Connection Method	Flared	

Indoor Unit Dimension

Unit: inch (mm)

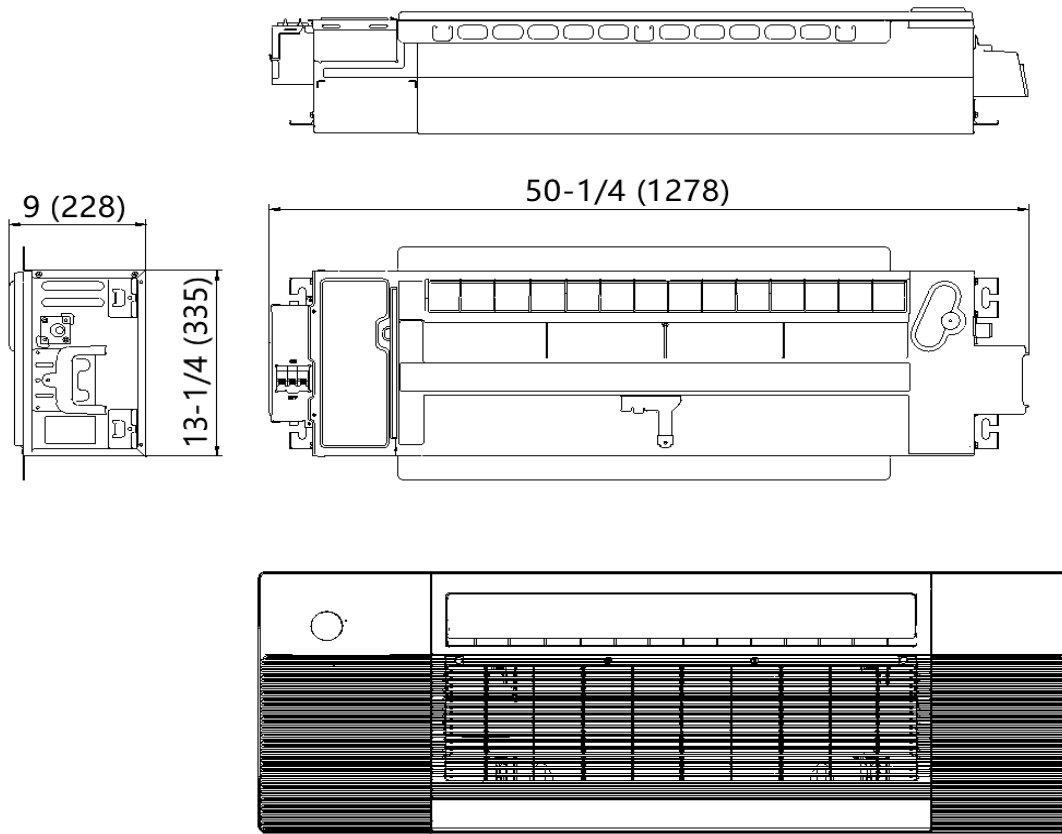

Installation Instruction

Installation place

(unit: inch/mm)

Perspective A

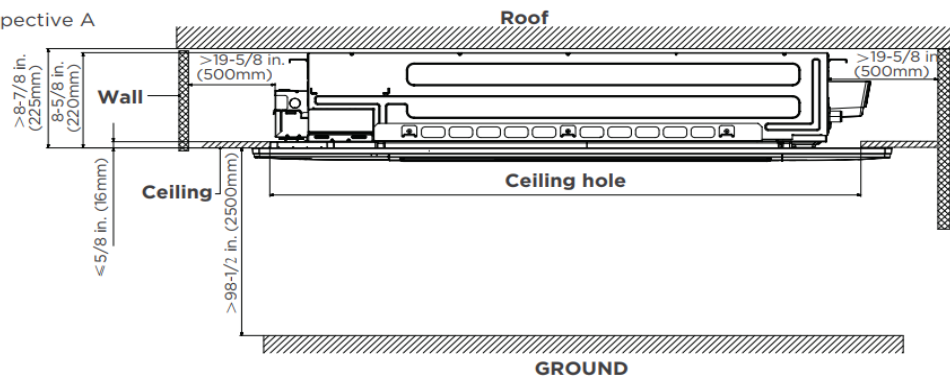

Perspective B

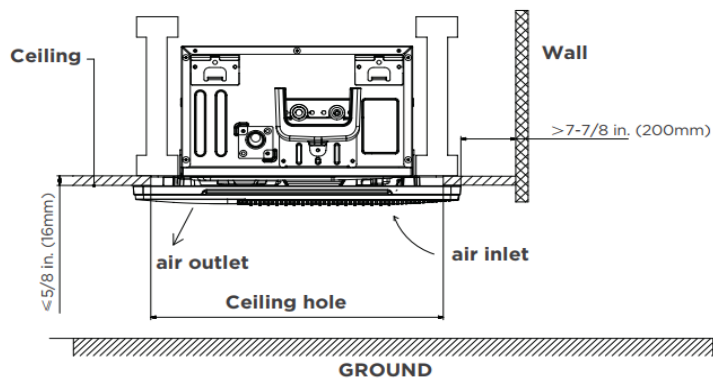

Outdoor Unit Dimension

Unit: inch (mm)

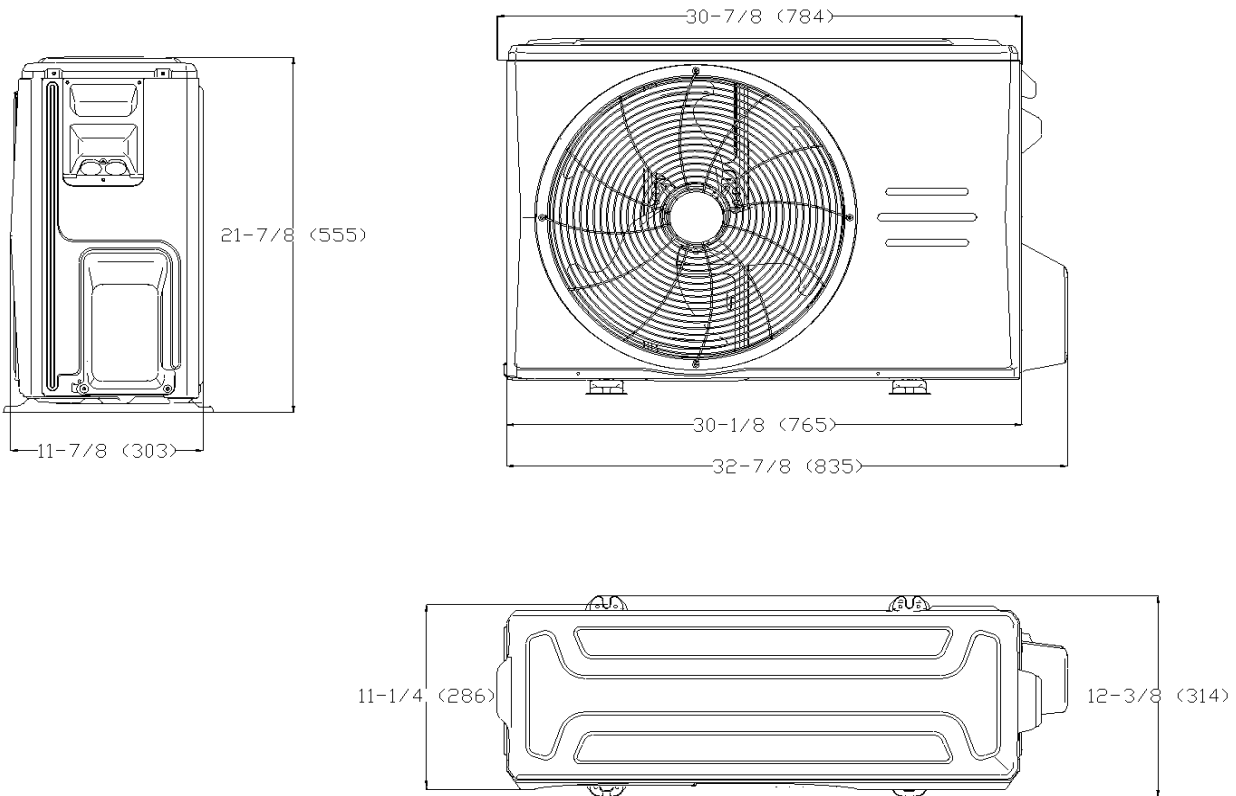

Installation Instruction

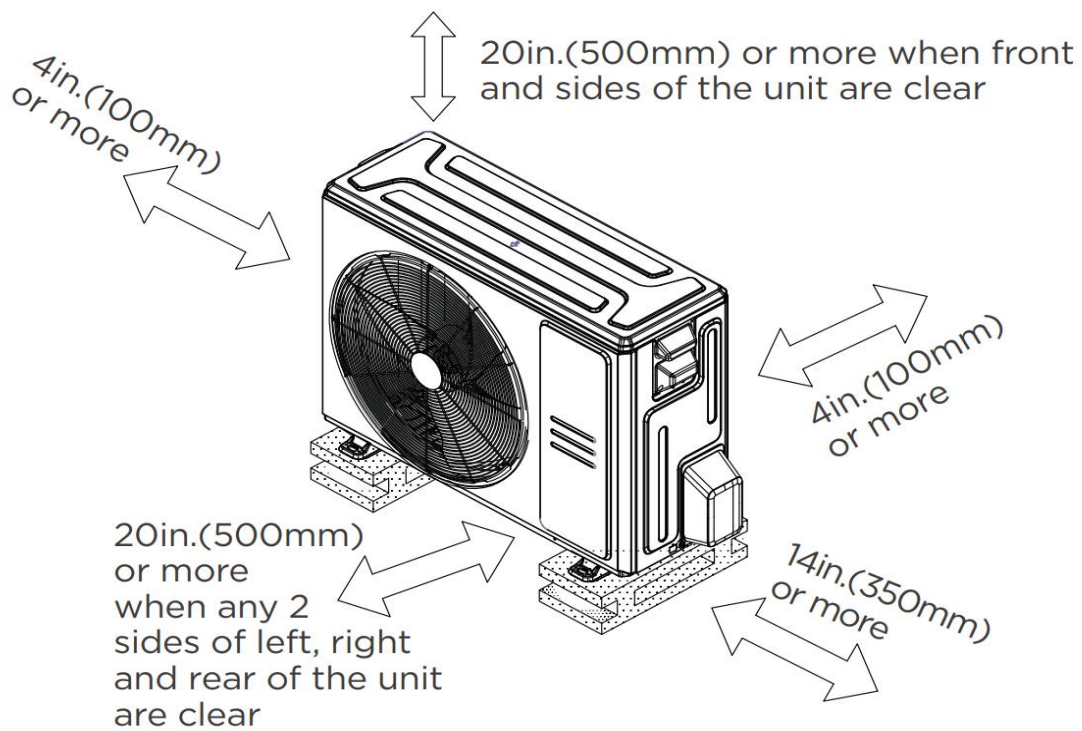

FEATURES

- Designed to fit between both I-joist spacing and traditional joist spacing
- Elevation panel
- Refrigerant leakage detection sensor(Optional)
- Humidity sensor
- Built-in pump
- Built-in circuit breaker
- 1~100% fan speed setting
- WiFi capability: through WiFi dongle or wired controller with built-in WiFi
- OTA(by using WiFi dongle)
- 2-pin connector(HA/HB) for programmable wired controller
- Multiple control options available:
 - Two way communication wired controller:120N(X6)
 - Two way communication wired controller with built-in WiFi:120N(X6W)
 - Infrared wired controller: 120L
 - Wireless remote controller
 - Third-Party 24V Thermostat*

*24V interface is required.

North American HVAC Products Ltd.

Add.: #100 5118 N Fraser Wy, Burnaby, BC V5J 0H1

Tel: 604-430-8496 info@nahvac.com www.nahvac.com

Midea reserves the right to change the specifications of the product, and to withdraw or replace products without prior notification or public announcement.
Midea is constantly developing and improving its products.