

R454b Refrigerant

SUBMITTAL DATA SHEET



Series Name: 4-Way Cassette Energy Star Series
Model Number: MCDHU-H12B-2A/ MO1ES-H12B-2A

4-Way Cassette Heat Pump System

Location:	Approval:
Engineer:	Date:
Submitted to:	Construction:
Submitted by:	Unit #:
Reference:	Drawing #:



INDOOR SPEINDOOR SPECIFICATIONCIFICATION

Indoor Air Flow (Turbo/H/M/L/Si) (CFM)	418 / 365 / 306 / 194 / 147	
Indoor Noise Level (Turbo/H/M/L/Si) (dBA)	46 / 42 / 39 / 27 / 24	
Dimension (WxDxH)	inch	22-1/2 x 22-1/2 x 9-5/8
	mm	570 x 570 x 245
Package (WxDxH)	inch	28-1/8 x 25-1/4 x 11-5/8
	mm	715 x 640 x 295
Net/Gross Weight	lbs	35/42
	kg	16/19

OUTDOOR SPECIFICATION

Compressor Type	ROTARY	
Compressor Model	KSK103D33UEZ3	
Refrigerant	R454B	
Refrigerant Oil Charge(mL)	310	
Refrigerant Oil	VG74	
Outdoor Air Flow (Max) (CFM)	1,236	
Outdoor Noise Level (dBA)	54.5	
Dimension (WxDxH)	inch	30-1/8 x 11-7/8 x 21-7/8
	mm	765 x 303 x 555
Package (WxDxH)	inch	34-7/8 x 13-1/4 x 24
	mm	887 x 337 x 610
Net/Gross Weight	lbs	63 / 68
	kg	28.2 / 30.7

EFFICIENCY

Cooling		Heating	
SEER2	21.1	HSPF2-4	10.4
EER2	12.5	COP	3.55

PERFORMANCE of Cooling

Cooling (Btu/hr)	
Rated Capacity	12,000
Min/Max Capacity	3,700~14,000
Moisture Removal(L/h)	1.10
Standard Operating Range(*F/*C)	-13~122 (-25 ~ 50)
Conditions:	Indoor: 80°F DB/67°F WB Outdoor: 95°F DB/75°F WB

PERFORMANCE of Heating

Heating (Btu/hr)	
1. @ 47°F Rated	12,000
1. @ 47°F Min/Max Capacity	4,700~15,000
2. @ 17°F Rated	8,500
3. @ 5°F Rated: Capacity / COP	8,400/2.4
3. @ 5°F Max: Capacity	8,400
Standard Operating Range(*F/*C)	-13~75 (-25 ~ 24)
1. Conditions:	Indoor: 70°F DB/60°F WB Outdoor: 47°F DB/43°F WB
2. Conditions:	Indoor: 70°F DB/60°F WB Outdoor: 17°F DB/15°F WB
3. Conditions:	Indoor: 70°F DB/60°F WB Outdoor: 5°F DB/5°F WB

ELECTRICAL

Power Supply	208/230V,60Hz,1Ph	
System MCA	12.0	
Connection Wiring	AWG 14/4	
System MOCP	15.0	
Compressor RLA	7.3	
Outdoor Fan Motor RLA	0.6	
Outdoor Fan Motor W	34	
Indoor Fan Motor RLA	0.9	
Indoor Fan Motor W	45	
System Power Input @ Cooling (W)	968 (220 ~ 1,160)	
System Power Input @ Heating (W)	991 (270 ~ 1,200)	
MCA: Min. circuit amps (A)	MOCP: Max. over current protection (A)	
RLA: Rated load amps (A)	W: Fan motor rated output (W)	

PIPING

Throttle type(Indoor)	N/A	
Throttle type(Outdoor)	EXV	
Liquid Size	1/4" (6.35mm)	
Gas Size	3/8" (9.52mm)	
Max. Piping Length(ft/m)	82 (25)	
Max. Height Difference(ft/m)	49 (15)	
Max. Pre-charged Length(ft/m)	25 (7.5)	
Refrigerant Pre-charged Amount(oz/kg)	32 (0.92)	
Additional Charge of Refrigerant((oz/ft)/(g/m)	0.16 (15)	
Connection Method	Flared	

Indoor Unit Dimension

Unit: inch (mm)

Liquid side Gas side

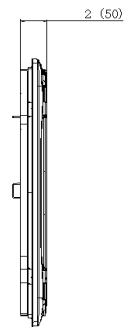
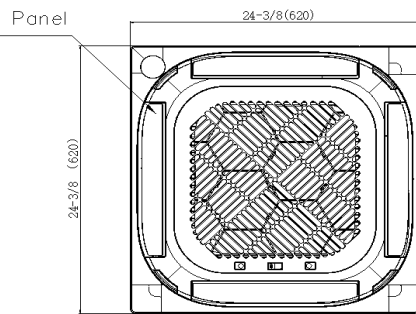
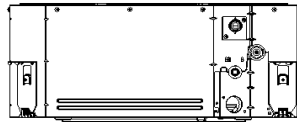
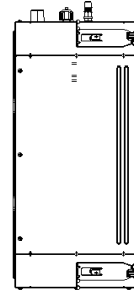
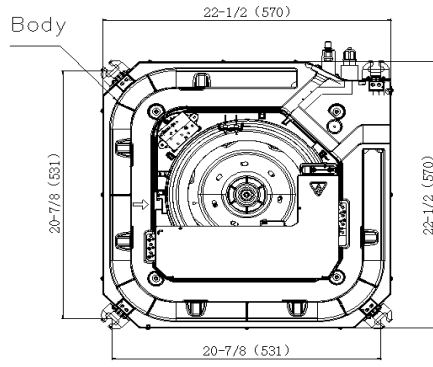
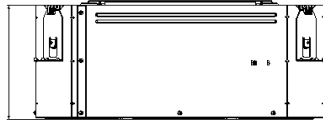
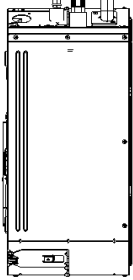

Outdoor Unit Dimension

Unit: inch (mm)

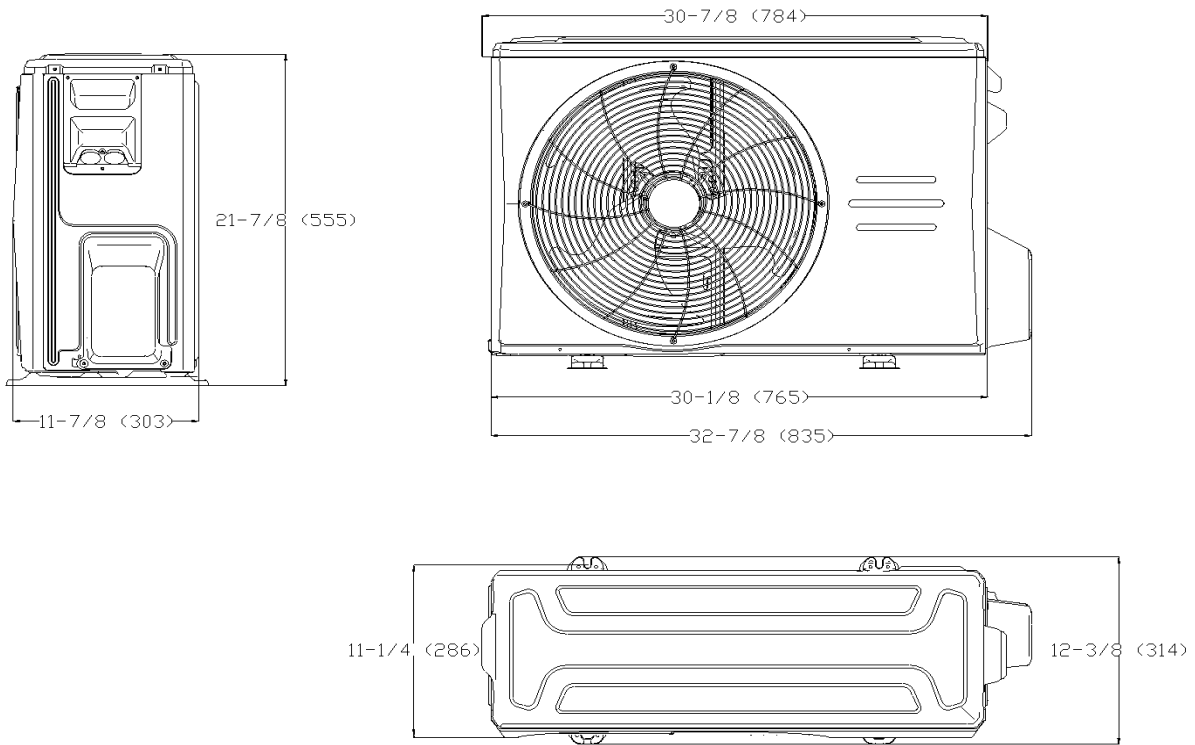

Installation Instruction

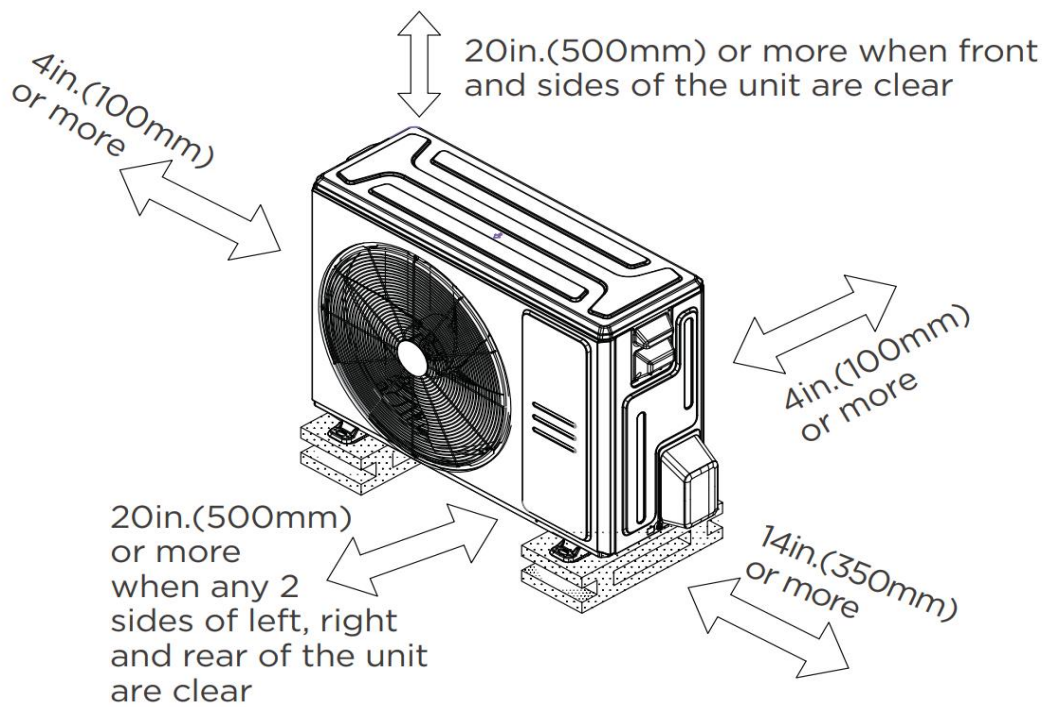

FEATURES

- 360° Air Flow
- Remote on-off and alarm ports
- Refrigerant leakage detection sensor(Optional)
- Humidity sensor
- Built-in pump
- 1~100% fan speed setting
- WiFi capability: through WiFi dongle or wired controller with built-in WiFi
- OTA(by using WiFi dongle)
- 2-pin connector(HA/HB) for programmable wired controller
- Multiple control options available:
 - Two way communication wired controller:120N(X6)
 - Two way communication wired controller with built-in WiFi:120N(X6W)
 - Infrared wired controller: 120L
 - Wireless remote controller
 - Third-Party 24V Thermostat*

*24V interface is required.

North American HVAC Products Ltd.

Add.: #100 5118 N Fraser Wy, Burnaby, BC V5J 0H1

Tel: 604-430-8496 info@nahvac.com www.nahvac.com

Midea reserves the right to change the specifications of the product, and to withdraw or replace products without prior notification or public announcement.
Midea is constantly developing and improving its products.