

R454b Refrigerant

SUBMITTAL DATA SHEET



Series Name: 4-Way Cassette Energy Star Series
Model Number: MCDHU-H18B-2A/MO1ES-H18B-2A

4-Way Cassette Heat Pump System

Location:	Approval:
Engineer:	Date:
Submitted to:	Construction:
Submitted by:	Unit #:
Reference:	Drawing #:



INDOOR SPEINDOOR SPECIFICATIONCIFICATION

Indoor Air Flow (Turbo/H/M/L/Si) (CFM)	447 / 389 / 318 / 194 / 147	
Indoor Noise Level (Turbo/H/M/L/Si) (dBA)	48 / 44 / 41 / 29 / 25	
Dimension (WxDxH)	inch	22-1/2 x 22-1/2 x 9-5/8
	mm	570 x 570 x 245
Package (WxDxH)	inch	28-1/8 x 25-1/4 x 11-5/8
	mm	715 x 640 x 295
Net/Gross Weight	lbs	35/42
	kg	16/19

OUTDOOR SPECIFICATION

Compressor Type	ROTARY	
Compressor Model	KSN140D58UFZ	
Refrigerant	R454B	
Refrigerant Oil Charge(mL)	440	
Refrigerant Oil	VG74	
Outdoor Air Flow (Max) (CFM)	1,766	
Outdoor Noise Level (dBA)	57.5	
Dimension (WxDxH)	inch	35 x 13-1/2 x 26-1/2
	mm	890 x 342 x 673
Package (WxDxH)	inch	39-1/8 x 15-5/8 x 29-1/8
	mm	995 x 398 x 740
Net/Gross Weight	lbs	93 / 100
	kg	42.0 / 45.5

EFFICIENCY

Cooling		Heating	
SEER2	20.7	HSPF2-4	11.4
EER2	12.5	COP	3.36

PERFORMANCE of Cooling

Cooling (Btu/hr)	
Rated Capacity	16,800
Min/Max Capacity	5,300~17,800
Moisture Removal(L/h)	2.05
Standard Operating Range(*F/*C)	-13~122 (-25 ~ 50)
Conditions:	Indoor: 80°F DB/67°F WB Outdoor: 95°F DB/75°F WB

PERFORMANCE of Heating

Heating (Btu/hr)	
1. @ 47°F Rated	18,000
1. @ 47°F Min/Max Capacity	7,100~21,500
2. @ 17°F Rated	13,900
3. @ 5°F Rated: Capacity / COP	12,800/2.2
3. @ 5°F Max: Capacity	12,800
Standard Operating Range(*F/*C)	-13~75 (-25 ~ 24)
1. Conditions:	Indoor: 70°F DB/60°F WB Outdoor: 47°F DB/43°F WB
2. Conditions:	Indoor: 70°F DB/60°F WB Outdoor: 17°F DB/15°F WB
3. Conditions:	Indoor: 70°F DB/60°F WB Outdoor: 5°F DB/5°F WB

ELECTRICAL

Power Supply	208/230V,60Hz,1Ph
System MCA	18.0
Connection Wiring	AWG 14/4
System MOCP	20.0
Compressor RLA	10.0
Outdoor Fan Motor RLA	0.9
Outdoor Fan Motor W	80
Indoor Fan Motor RLA	1.0
Indoor Fan Motor W	45
System Power Input @ Cooling (W)	1,344 (490 ~ 1,620)
System Power Input @ Heating (W)	1,570 (395 ~ 1,930)
MCA: Min. circuit amps (A)	MOCP: Max. over current protection (A)
RLA: Rated load amps (A)	W: Fan motor rated output (W)

PIPING

Throttle type(Indoor)	N/A
Throttle type(Outdoor)	EXV+Throttle valve
Liquid Size	1/4" (6.35mm)
Gas Size	1/2" (12.7mm)
Max. Piping Length(ft/m)	98.4 (30)
Max. Height Difference(ft/m)	66 (20)
Max. Pre-charged Length(ft/m)	25 (7.5)
Refrigerant Pre-charged Amount(oz/kg)	48 (1.36)
Additional Charge of Refrigerant((oz/ft)/(g/m)	0.16 (15)
Connection Method	Flared

Indoor Unit Dimension

inch (mm)

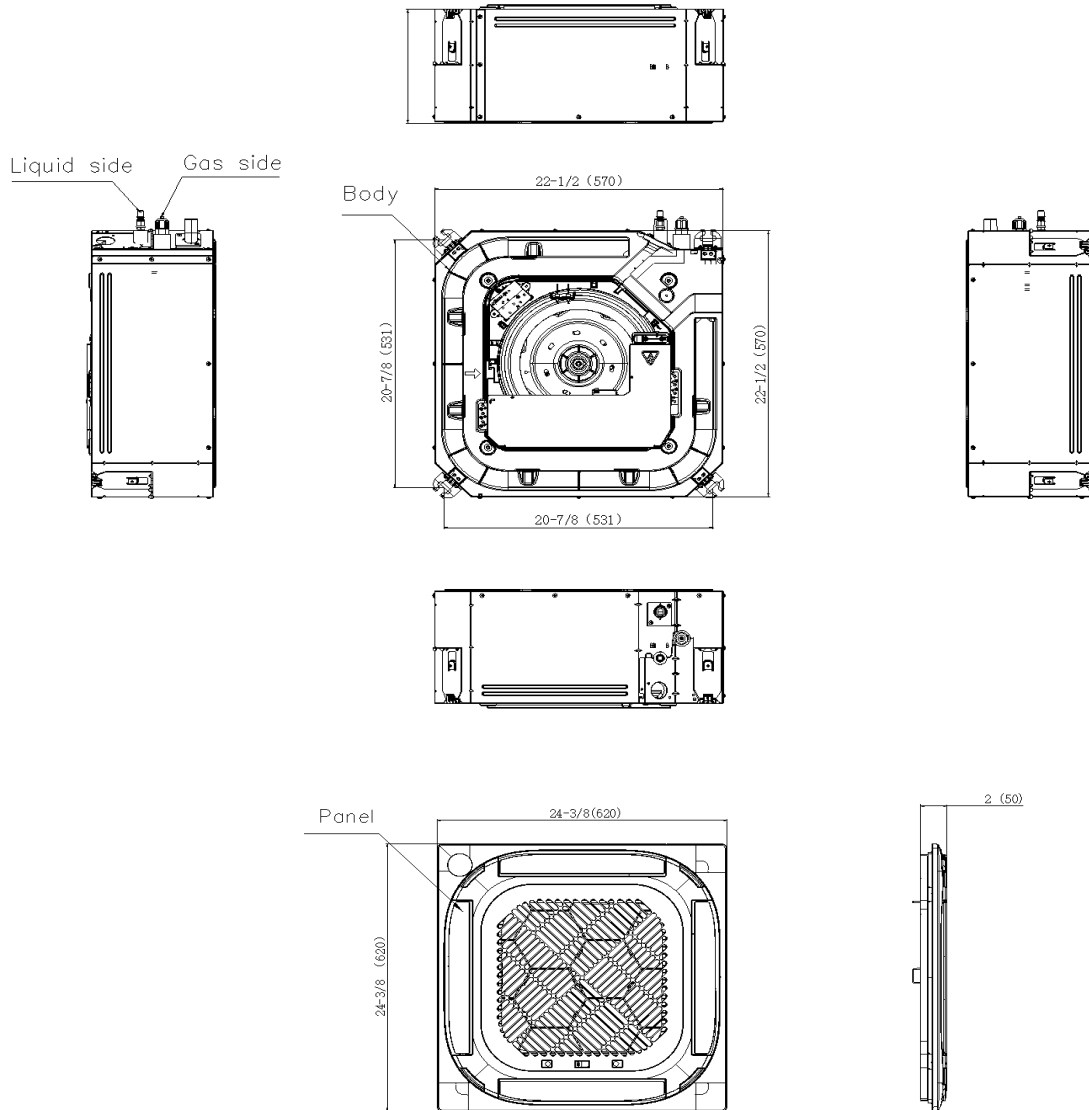

Installation Instruction

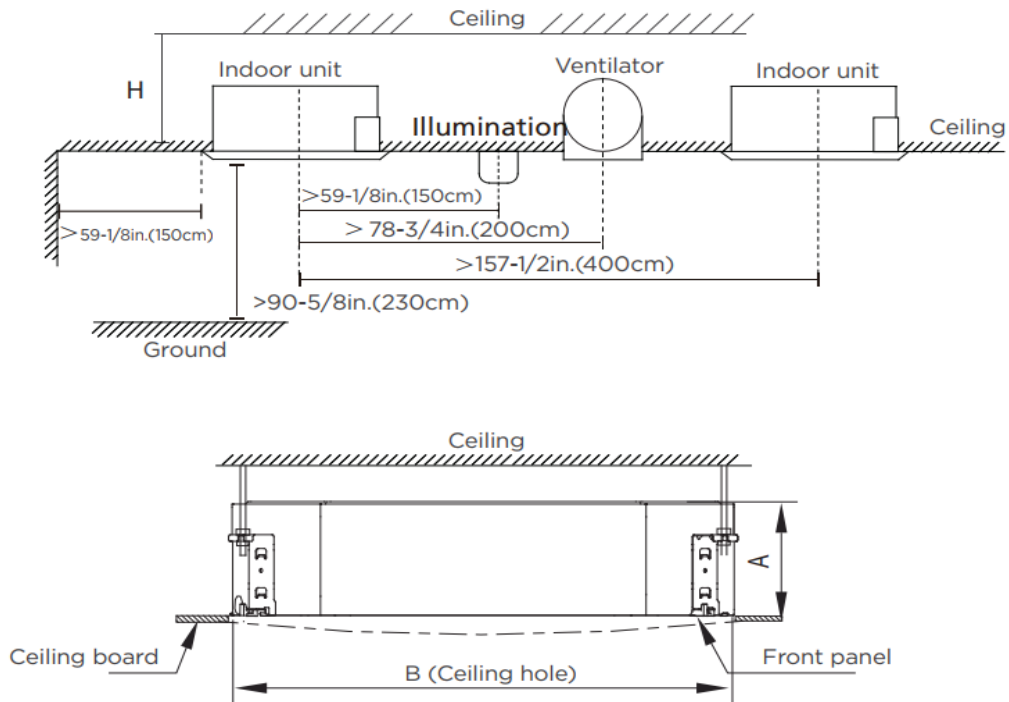

Distance from ceiling relative to height of indoor unit

MODEL	Length of A	Length of H	Length of B
9K/12K/18K	9-5/8 in.(245mm)	$>10\text{-}3/4\text{in.}(275\text{mm})$	23-5/8 in.(600mm)
24K	8 in.(205mm)	9 in.(230mm)	35-3/8 in.(900mm)
36K	9-5/8 in.(245mm)	10-3/4 in.(271mm)	
48K	11-1/4 in.(287mm)	12-1/4 in.(313mm)	

Outdoor Unit Dimension

Unit: inch (mm)

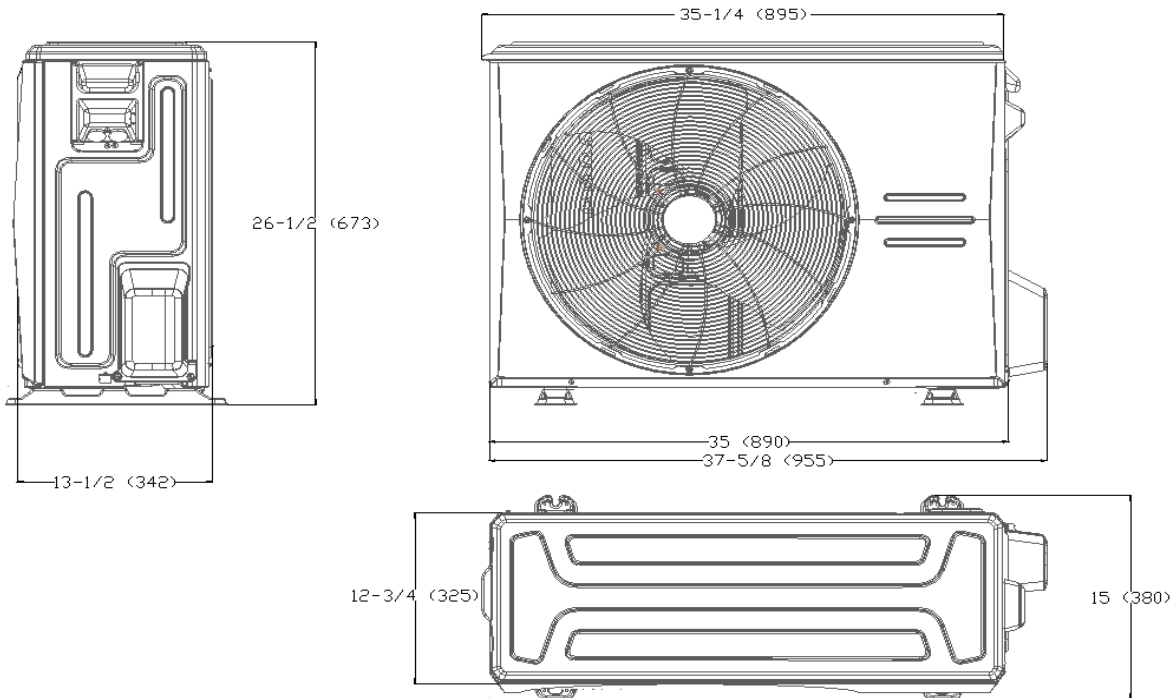

Installation Instruction

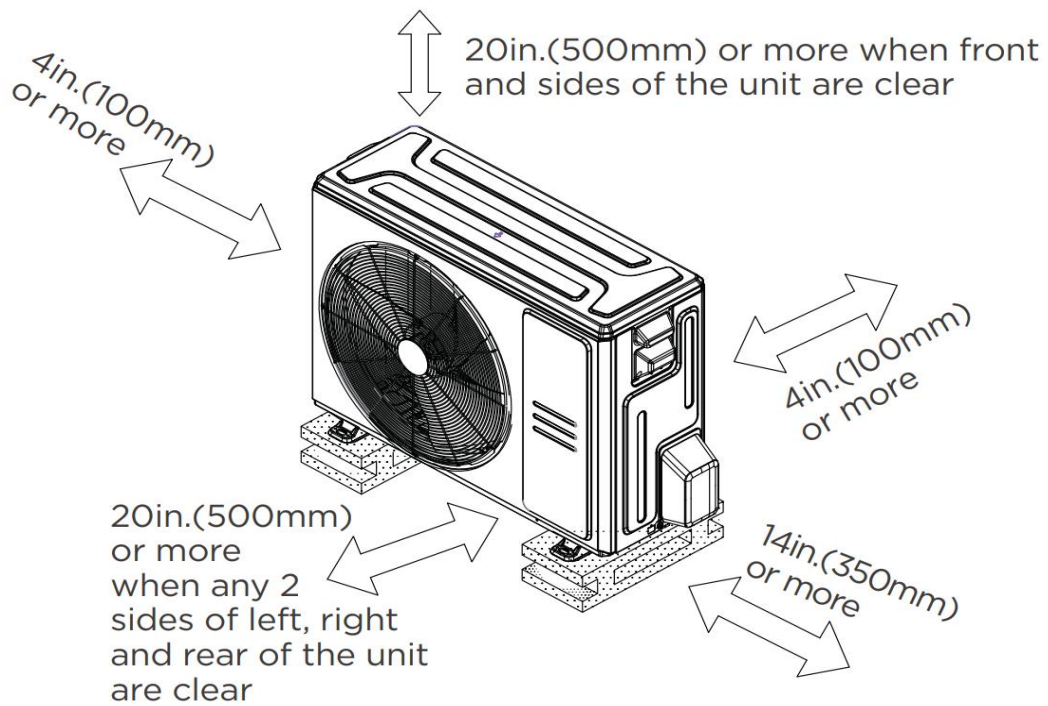

FEATURES

- 360° Air Flow
- Remote on-off and alarm ports
- Refrigerant leakage detection sensor(Optional)
- Humidity sensor
- Built-in pump
- 1~100% fan speed setting
- WiFi capability: through WiFi dongle or wired controller with built-in WiFi
- OTA(by using WiFi dongle)
- 2-pin connector(HA/HB) for programmable wired controller
- Multiple control options available:
 - Two way communication wired controller:120N(X6)
 - Two way communication wired controller with built-in WiFi:120N(X6W)
 - Infrared wired controller: 120L
 - Wireless remote controller
 - Third-Party 24V Thermostat*

*24V interface is required.

North American HVAC Products Ltd.

Add.: #100 5118 N Fraser Wy, Burnaby, BC V5J 0H1

Tel: 604-430-8496 info@nahvac.com www.nahvac.com

Midea reserves the right to change the specifications of the product, and to withdraw or replace products without prior notification or public announcement.
Midea is constantly developing and improving its products.