

# Midea Installation Manual

## Ceiling & Floor Air Conditioner

For 18,000 - 60,000 BTU Systems



### NOTE

Read the entire instruction manual before starting the installation. Images are for illustration purposes only. Actual models may differ slightly.



### Units Covered In This Manual

BTU/H	VOLTAGE/ PHASE	AIR HANDLER MODEL
18,000	208/230-1	MFBHU-H18B-2A
24,000	208/230-1	MFBHU-H24B-2A
36,000	208/230-1	MFBHS-H36B-2A
48,000	208/230-1	MFBHS-H48B-2A
60,000	208/230-1	MFBHS-H60B-2A



Manufacturer reserves the right to change, at any time, specifications and designs without notice and without obligations.

# Table of Contents

<b>Safety Considerations</b> .....	<b>3</b>	Fig. 3-3: Install Drainpipe Insulation .....	16
Table S-1: Approved Matchups .....	4	Fig. 3-3: Multi-Unit Drainpipe Arrangement .....	17
Table S-2: Minimum Room Area Requirements.....	4	<b>Outdoor Installation</b> .....	<b>17</b>
Table S-3: Minimum Room Area Requirements.....	5	Step 4 - Installation Location .....	17
Table S-3: Explanation of symbols displayed on the indoor unit or outdoor unit.....	7	Fig. 4-1: Clearance Dimensions.....	17
<b>Specifications</b> .....	<b>8</b>	Fig. 4-2: High Wind Installation .....	18
<b>Installation Accessories</b> .....	<b>9</b>	Step 5 - Install Drain Joint.....	18
Table A-1: Included Accessories.....	9	Fig. 5-1: Drain Joint Types.....	18
Table A-2: Optional Accessories.....	9	Step 6 - Anchor Outdoor Unit.....	19
Table A-3: Pipe Specification .....	9	Fig. 6-1: Unit Dimensions.....	19
Unpacking .....	9	Table 6-1: Outdoor Unit Dimensions.....	19
<b>Product Overview</b> .....	<b>10</b>	Table 6-2: Multiple Unit Clearances .....	19
<b>Dimensions &amp; Clearances</b> .....	<b>11</b>	Fig. 6-2: Clearances for Multiple Units.....	19
Fig. D-1: Unit Clearances .....	11	Step 7 - Refrigerant Piping Connection.....	20
Fig. D-2: Unit Dimensions .....	11	Table 7-1: Pipe Length & Elevation.....	20
Table D-1: Unit Dimensions .....	11	Fig. 7-1: Oil Trap Arrangement.....	20
<b>Installation Summary</b> .....	<b>12</b>	Fig. 7-2: Correct Pipe Cutting .....	20
<b>Installation Requirements</b> .....	<b>13</b>	Fig. 7-3: Reamer Tool .....	20
<b>Indoor Installation</b> .....	<b>14</b>	Fig. 7-4: Copper pipe and flare nut.....	21
Step 1 - Hang The Indoor Unit.....	14	Fig. 7-5: Flare Form.....	21
Fig. 1-1: Install Bolts Into Wood Mounting.....	14	Fig. 7-6: Flare Shape.....	21
Fig. 1-2: Embed Screw Bolts In Concrete .....	14	Table 7-2: Flare Dimensions/Tightening Torque.....	21
Fig. 1-3: Use Expandable Bolts.....	14	Fig. 7-7: Align the center of the two pipes.....	21
Fig. 1-4: Install Bolts Into Angle Steel.....	14	Fig. 7-8: Spanner and Torque Wrench .....	21
Fig. 1-5: Hang Unit Using Suspension Bolts .....	14	Fig. 7-9: Bend the Tubing.....	22
Fig. 1-6: Expose The Hanging Arms.....	15	Step 8 - Outdoor Unit Wiring .....	22
Fig. 1-7: Hanging Bolt Arrangement.....	15	Fig. 8-1: Wiring Overview.....	23
Fig. 1-8: Leave Enough Space Between The Unit And Ceiling.....	15	Fig. 8-2: Remove Electrical Cover.....	23
Fig. 1-9: Ceiling-Mount Piping Arrangement.....	15	Fig. 8-3: Connection Diagram .....	23
Fig. 1-10: Conduit Plate Installation.....	15	Fig. 8-4: Super-Slim Models.....	24
Fig. 1-11: Cord Conduit Attached To Unit .....	15	Fig. 8-5: Magnetic Ring Installation .....	24
Fig. 1-12: Wall-Mount Piping Arrangement .....	15	Step 9 - Air Evacuation.....	24
Fig. 1-13: Rubber Rings Location .....	16	Fig. 9-1: Manifold Gauge Arrangement.....	24
Fig. 1-14: Installation Plate Location.....	16	Fig. 9-2: Service Valve .....	25
Step 2 - Drill The Wall .....	16	Table 9-1: Additional Refrigerant Formula .....	25
Fig. 2-1: Drill The Wall Hole At An Angle.....	16	<b>Test Run</b> .....	<b>25</b>
Step 3 - Connect Drain Hose .....	16	Trademarks Copyrights & Legal Statement .....	26
Fig. 3-1: Drainpipe Connection.....	16	Disposal & Recycling.....	26
		Data Protection Notice.....	26

# Safety Considerations

It is crucial to read the Safety Precautions Before Operation and Installation. Neglecting these instructions may lead to serious damage or injury. The severity of potential damage or injuries is categorized as either a WARNING or CAUTION.

## WARNING

Hazards or unsafe practices that may result in severe personal injury or death.

## CAUTION

Hazards or unsafe practices may result in minor personal injury or property damage. Carefully follow the precautions because they are essential to guarantee the safety of the equipment.

### NOTE

A property-damage-only hazard, meaning no personal injury is possible.

### IMPORTANT

Is used to highlight suggestions which will result in enhanced installation, reliability, or operation.

## WARNING

State of California Proposition 65 Warning (US Only)  
This product contains chemicals known to the State of California to cause cancer, birth defects, or other reproductive harm.

## WARNING

Improper installation, adjustment, alteration, service, maintenance, or use can cause an explosion, fire, electrical shock, or other conditions that may cause death, personal injury, or property damage. Consult a qualified installer, service agency, distributor, or branch for information or assistance. The qualified installer or agency must use factory-authorized kits or accessories when modifying this product. Refer to the individual instructions packaged with kits or accessories when installing.

### IMPORTANT

Follow all safety codes. Wear safety glasses, protective clothing, and work gloves. Have a fire extinguisher available. Read these instructions thoroughly and follow all warnings or cautions in the literature and labels attached to the unit. Consult local building codes and the current editions of the National Electrical Code (NEC) NFPA 70.

### IMPORTANT

In Canada, refer to the current editions of the Canadian Electrical Code CSA C22.1. Follow the safety information.

## WARNING

This appliance is not intended for use by persons (including children) with reduced physical, sensory, or mental capabilities, or lack of experience and knowledge, unless  
**Ceiling & Floor Air Conditioner**

they have been given supervision or instruction concerning use of the appliance by a person responsible for their safety. Children should be supervised to ensure that they do not play with the appliance.

## WARNING

### ELECTRICAL WARNINGS

- Only use the specified wire. If the wire is damaged, it must be replaced by the manufacturer, service agent, or similarly qualified persons to avoid a hazard.
- The product must be properly grounded at the time of installation, or electric shock may occur.
- For all electrical work, follow all local and national wiring standards, regulations, and the Installation Manual. Connect cables tightly and clamp them securely to prevent external forces from damaging the terminal. Improper electrical connections can overheat, cause fire, and may also cause shock. All electrical connections must be made according to the Electrical Connection Diagram located on the panels of the indoor and outdoor units.
- All wiring must be properly arranged to ensure that the control board cover can close properly. If the control board cover is not closed properly, it can lead to corrosion and cause the connection points on the terminal to heat up, catch fire, or cause electrical shock.
- Disconnection must be incorporated in the fixed wiring in accordance with the NEC, CEC, or local codes.
- **DO NOT** share the electrical outlet with other appliances. The unit must be installed on a dedicated electrical circuit.
- If connecting power to fixed wiring, an all-pole disconnection device that has at least 3/32 in. (3 mm) clearances in all poles, and has a leakage current that may exceed 10 mA, the residual current device (RCD) having a rated residual operating current not exceeding 30 mA, and disconnection must be incorporated in the fixed wiring in accordance with the wiring rules.

## WARNING

### WARNINGS FOR PRODUCT INSTALLATION

- Turn off the air conditioner and disconnect the power before performing any installation or repair. Failure to do so can cause electric shock.
- Installation must be performed by an authorized dealer or specialist. Defective installation can cause water leakage, electrical shock, or fire.
- Installation must be performed according to the installation instructions. Improper installation can cause water leakage, electrical shock, or fire. Contact an authorized service technician for repair or maintenance of this unit.
- This appliance shall be installed in accordance with national wiring regulations. Only use the included accessories, parts, and specified parts for installation.
- Using non-standard parts can cause water leakage, electrical shock, and fire, and can cause the unit to fail.
- Install the unit in a firm location that can support the

unit's weight. If the chosen location cannot support the unit's weight, or the installation is not done properly, the unit may drop and cause serious injury and damage.

- Install drainage piping according to the instructions in this manual. Improper drainage may cause water damage to your home and property.
- For units that have an auxiliary electric heater, do not install the unit within (3 ft. (1 m) of any combustible materials.
- For the units that have a wireless network function, USB device access, replacement, and maintenance operations must be carried out by professional staff.
- **Do not** install the unit in a location that may be exposed to combustible gas leaks. If combustible gas accumulates around the unit, it may cause fire.
- **Do not** turn on the power until all work has been completed.
- When moving or relocating the air conditioner, consult experienced service technicians for disconnection and reinstallation of the unit.
- How to install the appliance to its support, please read the information for details in the "indoor unit installation" and "outdoor unit installation" sections.

**⚠ WARNING**

**TAKE NOTE OF FUSE SPECIFICATIONS**

The air conditioner's circuit board (PCB) is designed with a fuse to provide overcurrent protection. The fuse specifications are printed on the circuit board, such as T3.15 AL/250 VAC, T5 AL/250 VAC, T3.15 A/250 VAC, T5 A/250 VAC, T2 0A/250 VAC, T30 A/250 VAC, etc.

**NOTE**

Only the blast-proof ceramic fuse can be used.

**⚠ WARNING**

**USING FLAMMABLE REFRIGERANT**

- Do not use means to accelerate the defrosting process or to clean, other than those recommended by the manufacturer.
- The appliance shall be stored in a room without continuously operating ignition sources (for example: open flames, an operating gas appliance, or an operating electric heater).
- Do not pierce or burn.
- Be aware that refrigerants may not contain an odor.

**For R454B refrigerant charge amount and minimum room area:**

The machine you purchased may be one of the types in the table below. The indoor and outdoor units are designed to be used together, and the indoor unit is connected via an air duct system to one or more rooms. Please check the machine you purchased. The height of the room cannot be less than 7.3 ft./2.2 m, and the minimum room area for operating or storage should be as specified in the following table:

**Table S-1: Approved Matchups**

Model	Indoor unit	Outdoor unit
18K	MFBHU-H18B-2A	MO1HS-H18B-2A
		MO1ES-H18B-2A
24K	MFBHU-H24B-2A	MO1HS-H24B-2A
		MO1ES-H24B-2A
36K	MFBHS-H36B-2A	MO1BU-H36B-2A
		MO1HU-H36B-2A
48K	MFBHS-H48B-2A	MO1HU-H48B-2A
		MO1BU-H48B-2A
60K	MFBHS-H60B-2A	MO1HU-H60B-2A
		MO1BU-H60B-2A

**NOTE**

This air conditioner can be installed on the wall or suspended from the ceiling.

**Table S-2: Minimum Room Area Requirements**

Amin [ft. <sup>2</sup> /m <sup>2</sup> ]	hinst[ft/m]				
	6.0~7.3/ 1.8~2.2	7.9/2.4	8.6/2.6	9.2/2.8	9.9/3.0
≤62.6/1.776	12/1.10				
63.4/1.8	60/5.53	55/5.07	51/4.68	47/4.35	44/4.06
70.5/2.0	67/6.15	61/5.64	56/5.20	52/4.83	49/4.51
77.5/2.2	73/6.76	67/6.20	62/5.72	58/5.31	54/4.96
84.6/2.4	80/7.38	73/6.76	68/6.24	63/5.80	59/5.41
91.7/2.6	86/7.99	79/7.32	73/6.76	68/6.28	64/5.86
98.7/2.8	93/8.60	85/7.89	79/7.28	73/6.76	68/6.31
105.8/3.0	100/9.22	91/8.45	84/7.80	78/7.24	73/6.76
112.8/3.2	106/9.83	97/9.01	90/8.32	84/7.73	78/7.21
119.9/3.4	113/10.45	104/9.58	96/8.84	89/8.21	82/7.66
126.9/3.6	120/11.06	110/10.14	101/9.36	94/8.69	88/8.11
134/3.8	126/11.68	116/10.70	107/9.88	99/9.17	93/8.56
141.0/4.0	133/12.29	122/11.27	112/10.40	104/9.66	97/9.01
148.1/4.2	139/12.90	128/11.83	118/10.92	110/10.14	102/9.46
155.1/4.4	146/13.52	134/12.39	124/11.44	115/10.62	107/9.91
162.2/4.6	153/14.13	140/12.96	129/11.96	120/11.11	112/10.37
169.2/4.8	159/14.75	146/13.52	135/12.48	125/11.59	117/10.82
176.3/5.0	166/15.36	152/14.08	140/13.00	130/12.07	122/11.27
Area formula	<p><b>Amin</b> is the required minimum area in ft.<sup>2</sup>/m<sup>2</sup>  <b>Mc</b> is the actual refrigerant charge in the system in oz/kg  <b>MREL</b> is the refrigerant releasable charge in oz./kg  <b>hinst</b> is the height of the bottom of the appliance relative to the floor of the room after installation.  <b>WARNING:</b> The minimum room area or minimum room area of conditioned space is based on releasable charge and total system refrigerant charge.</p>				

Amin [ft. <sup>2</sup> /m <sup>2</sup> ]	hinst[ft/m]		
mc or mREL [oz/kg]	0	0.7~2.0 0.2-0.6	2.7~4.0 0.8~1.2
≤62.6/1.776	12/1.10		
63.4/1.8	60/5.53	14p3.5	60/5.53
70.5/2.0	67/6.15	67/6.15	67/6.15
77.5/2.2	73/6.76	73/6.76	73/6.76
84.6/2.4	80/7.38	80/7.38	80/7.38
91.7/2.6	86/7.99	86/7.99	86/7.99
98.7/2.8	93/8.60	93/8.60	93/8.60
105.8/3.0	100/9.22	100/9.22	100/9.22
112.8/3.2	106/9.83	106/9.83	106/9.83
119.9/3.4	113/10.45	113/10.45	113/10.45
126.9/3.6	120/11.06	120/11.06	120/11.06
134/3.8	126/11.68	126/11.68	126/11.68
141.0/4.0	133/12.29	133/12.29	133/12.29
148.1/4.2	139/12.90	139/12.90	139/12.90
155.1/4.4	146/13.52	146/13.52	146/13.52
162.2/4.6	153/14.13	153/14.13	153/14.13
169.2/4.8	159/14.75	159/14.75	159/14.75
176.3/5.0	166/15.36	166/15.36	166/15.36
Area formula	<p><b>Amin</b> is the required minimum area of the total conditioned space connected by air ducts in ft.<sup>2</sup>/m<sup>2</sup></p> <p><b>Mc</b> is the actual refrigerant charge in the system in oz/kg</p> <p><b>MREL</b> is the refrigerant releasable charge in oz./kg</p> <p><b>hinst</b> is the height of the bottom of the appliance relative to the floor of the room after installation.</p> <p><b>WARNING:</b> The minimum room area or minimum room area of conditioned space is based on releasable charge and total system refrigerant charge.</p>		

**Table S-3: Minimum Room Area Requirements**

Model	18K	24K	36K	48K	60K
Nominal Air Volume	577 CFM (980 m <sup>3</sup> /h)	736 CFM (1250 m <sup>3</sup> /h)	1224 CFM (2080 m <sup>3</sup> /h)	1353 CFM (2300 m <sup>3</sup> /h)	1365 CFM (2320 m <sup>3</sup> /h)

**1. Installation** (where refrigerant pipes are allowed)

- Any person who is involved with working on or breaking into a refrigerant circuit should hold a current valid certificate from an industry-accredited assessment authority, which authorizes their competence to handle refrigerants safely in accordance with an industry-recognized assessment specification.
- Maintenance and repair requiring the assistance of other skilled personnel shall be carried out under the supervision of the person competent in the use of flammable refrigerants.
- That the installation of pipe work shall be kept to a minimum.
- That pipe work shall be protected from physical damage.
- Where refrigerant pipes shall comply with national gas regulations.
- That mechanical connections shall be accessible for maintenance purposes.
- Be more careful that foreign matter (oil, water, etc.) does not enter the piping. Also, when storing the piping, securely seal the opening by pinching, taping, etc.
- All working procedures that affect safety means shall only be carried out by competent technicians.

- Appliance shall be stored in a well-ventilated area where the room size corresponds to the room area as specified for operation.
- Joints shall be tested with detection equipment with a capability of 5 g/year of refrigerant or better, with the equipment in a standstill and under operation or under pressure of at least these standstill or operation conditions after installation. Detachable joints should NOT be used on the indoor side of the unit (brazed, welded joints could be used).
- In cases that require mechanical ventilation, ventilation openings shall be kept clear of obstruction.
- LEAK DETECTION SYSTEM installed. The unit must be powered except for service. For the unit with a refrigerant sensor, when the refrigerant sensor detects refrigerant leakage, the indoor unit will display an error code and emit a buzzing sound, the compressor of the outdoor unit will immediately stop, and the indoor fan will start running. The service life of the refrigerant sensor is 15 years. When the refrigerant sensor malfunctions, the indoor unit will display the error code "FHCC". The refrigerant sensor cannot be repaired and can only be replaced by the manufacturer. It shall only be replaced with the sensor specified by the manufacturer.

**2. When a FLAMMABLE REFRIGERANT is used,** the

- requirements for installation space of appliance and/or ventilation requirements are determined according to
- the mass charge amount (M) used in the appliance,
  - the installation location,
  - the type of ventilation of the location or the appliance.
  - piping material, pipe routing, and installation shall include protection from physical damage in operation and service, and comply with national and local codes and standards, such as ASHRAE 15, IAPMO Uniform Mechanical Code, ICC International Mechanical Code, or CSA B52. All field joints shall be accessible for inspection before being covered or enclosed.
  - that protection devices, piping, and fittings shall be protected as far as possible against adverse environmental effects, for example, the danger of water collecting and freezing in relief pipes or the accumulation of dirt and debris;
  - that piping in refrigeration systems shall be so designed and installed to minimize the likelihood of hydraulic shock damaging the system;
  - that steel pipes and components shall be protected against corrosion with a rustproof coating before applying any insulation;
  - that precautions shall be taken to avoid excessive vibration or pulsation;
  - the minimum floor area of the room shall be mentioned in the form of a table or a single figure without reference to a formula;
  - after completion of field piping for split systems, the field pipework shall be pressure tested with an inert gas and then vacuum tested before refrigerant charging, according to the following requirements:
    - a. The minimum test pressure for the low side of the system shall be the low side design pressure and the minimum test pressure for the high side of the system

shall be the high side design pressure, unless the high side of the system can not be isolated from the low side of the system in which case the entire system shall be pressure tested to the low side design pressure.

- b. The test pressure after removal of the pressure source shall be maintained for at least 1 h with no decrease of pressure indicated by the test gauge, with test gauge resolution not exceeding 5% of the test pressure.
  - c. During the evacuation test, after achieving a vacuum level specified in the manual or less, the refrigeration system shall be isolated from the vacuum pump and the pressure shall not rise above 1500 microns within 10 min. The vacuum pressure level shall be specified in the manual and shall be the lessor of 500 microns or the value required for compliance with national and local codes and standards, which may vary between residential, commercial, and industrial buildings.
- field-made refrigerant joints indoors shall be tightness tested according to the following requirements: The test method shall have a sensitivity of 5 grams per year of refrigerant or better under a pressure of at least 0,25 times the maximum allowable pressure. No leak shall be detected.

### 3 . Qualification of workers

Any maintenance, service, and repair operations must require the qualification of the working personnel. Every working procedure that affects safety means shall only be carried out by competent technicians who joined the training and achieved competence should be documented by a certificate. The training of these procedures is carried out by national training organizations or manufacturers that are accredited to teach the relevant national competency standards that may be set in legislation. All training shall follow the ANNEX HH requirements of UL 60335-2-40 4th Edition.

Examples of such working procedures are:

- breaking into the refrigerating circuit;
- opening of sealed components;
- opening of ventilated enclosures.

### 4. Ventilated area

Ensure that the area is in the open or that it is adequately ventilated before breaking into the system or conducting any hot work. A degree of ventilation shall continue during the period that the work is carried out. The ventilation should safely disperse any released refrigerant and preferably expel it externally into the atmosphere.

### 5. Wiring

Check that cabling will not be subject to wear, corrosion, excessive pressure, vibration, sharp edges, or any other adverse environmental effects. The check shall also take into account the effects of aging or continual vibration from sources such as compressors or fans.

### 6. Detection of flammable refrigerants

Under no circumstances shall potential sources of ignition be used in the search for or detection of refrigerant leaks. A halide torch (or any other detector using a naked flame) shall not be used.

The following leak detection methods are deemed acceptable for refrigerant systems. Electronic leak detectors may be used to detect refrigerant leaks but, in

the case of FLAMMABLE REFRIGERANTS, the sensitivity may not be adequate, or may need re-calibration. (Detection equipment shall be calibrated in a refrigerant-free area.) Ensure that the detector is not a potential source of ignition and is suitable for the refrigerant used. Leak detection equipment shall be set at a percentage of the LFL of the refrigerant and shall be calibrated to the refrigerant employed, and the appropriate percentage of gas (25 % maximum) is confirmed. Leak detection fluids are also suitable for use with most refrigerants but the use of detergents containing chlorine shall be avoided as the chlorine may react with the refrigerant and corrode the copper pipe-work.

### NOTE

Examples of leak-detection fluids are

- bubble method,
- fluorescent method agents.

If a leak is suspected, all naked flames shall be removed/ extinguished.

If leakage of refrigerant is found which requires brazing, all of the refrigerant shall be recovered from the system, or isolated (using shut-off valves) in a part of the system remote from the leak. See the following instructions for the removal of refrigerant.

### 7. Removal and evacuation

When breaking into the refrigerant circuit to make repairs - or for any other purpose conventional procedures shall be used. However, for flammable refrigerants best practice must be followed since flammability is a consideration.

The following procedure shall be adhered to:

- safely remove refrigerant following local and national regulations;
- evacuate;
- purge the circuit with inert gas (optional for A2L);
- evacuate (optional for A2L);
- continuously flush or purge with inert gas when using a flame to open the circuit; and
- open the circuit.

The refrigerant charge shall be recovered into the correct recovery cylinders if venting is not allowed by local and national codes. For appliances containing flammable refrigerants, the system shall be purged with oxygen-free nitrogen to render the appliance safe for flammable refrigerants. This process might need to be repeated several times. Compressed air or oxygen shall not be used for purging refrigerant systems.

For appliances containing flammable refrigerants, refrigerant purging shall be achieved by breaking the vacuum in the system with oxygen-free nitrogen and continuing to fill until the working pressure is achieved, then venting to the atmosphere, and finally pulling down to a vacuum (optional for A2L). This process shall be repeated until no refrigerant is within the system (optional for A2L). When the final oxygen-free nitrogen charge is used, the system shall be vented down to atmospheric pressure to enable work to take place.

The outlet for the vacuum pump shall not be close to any potential ignition sources, and ventilation shall be available.

### 8. Charging procedures

In addition to conventional charging procedures, the

following requirements shall be followed:





- Works shall be undertaken with appropriate tools only (In case of uncertainty, please consult the manufacturer of the tools for use with flammable refrigerants) Ensure that contamination of different refrigerants does not occur when using charging equipment. Hoses or lines shall be as short as possible to minimize the amount of refrigerant contained in them.
- Ensure that the refrigeration system is earthed before charging the system with refrigerant.
- Label the system when charging is complete(if not already). Extreme care shall be taken not to overfill the refrigeration system.
- Before recharging the system, it shall be pressure tested with oxygen-free nitrogen (OFN). The system shall be leak tested on completion of charging but before commissioning. A follow-up leak test shall be carried out before leaving the site.

### 9. Recovery

When removing refrigerant from a system, either for servicing or decommissioning, it is recommended good practice that all refrigerants are removed safely.

When transferring refrigerant into cylinders, ensure that only appropriate refrigerant recovery cylinders are employed. Ensure that the correct number of cylinders for holding the total system charge is available. All cylinders to be used are designated.

**Table S-3: Explanation of symbols displayed on the indoor unit or outdoor unit**

	<p><b>WARNING</b></p>	<p>This symbol shows that this appliance used a flammable refrigerant. If the refrigerant is leaked and exposed to an external ignition source, there is a risk of fire.</p>
	<p><b>CAUTION</b></p>	<p>This symbol shows that the operation manual should be read carefully.</p>
	<p><b>CAUTION</b></p>	<p>This symbol shows that service personnel should be handling this equipment referencing the installation manual.</p>
	<p><b>CAUTION</b></p>	<p>This symbol shows that information is available such as the operating manual or installation manual.</p>



Caution: Risk of fire/flammable materials














# Specifications

<b>Product Model</b>	<b>MFBHU-H18B-2A MO1HS-H18B-2A</b>	<b>MFBHU-H18B-2A MO1ES-H18B-2A</b>	<b>MFBHU-H24B-2A MO1HS-H24B-2A</b>	<b>MFBHU-H24B-2A MO1ES-H24B-2A</b>
Power source	208/230V~ 60Hz, 1Ph			
Cooling capacity	17000Btu/h	18000Btu/h	22000Btu/h	24000Btu/h
Heating capacity	19000Btu/h	18000Btu/h	26000Btu/h	24400Btu/h
Moisture resistance class	IPX4			
<b>Product Model</b>	<b>MFBHS-H36B-2A MO1BU-H36B-2A</b>	<b>MFBHS-H36B-2A MO1HU-H36B-2A</b>	<b>MFBHS-H48B-2A MO1HU-H48B-2A</b>	<b>MFBHS-H48B-2A MO1BU-H48B-2A</b>
Power source	208/230V~ 60Hz, 1Ph			
Cooling capacity	36400Btu/h	36000Btu/h	48000Btu/h	48000Btu/h
Heating capacity	38000Btu/h	38000Btu/h	50000Btu/h	52000Btu/h
Moisture resistance class	IPX4			
<b>Product Model</b>	<b>MFBHS-H60B-2A MO1HU-H60B-2A</b>		<b>MFBHS-H60B-2A MO1BU-H60B-2A</b>	
Power source	208/230V~ 60Hz, 1Ph			
Cooling capacity	54000Btu/h		54000Btu/h	
Heating capacity	60000Btu/h		60000Btu/h	
Moisture resistance class	IPX4			

# Installation Accessories

The air conditioning system comes with the following accessories. Use all of the installation parts and accessories to install the air conditioner. Improper installation may result in water leakage, electrical shock, and fire, or cause the equipment to fail. The items that are not included in the air conditioner must be purchased separately.




**Table A-1: Included Accessories**

QTY.	Part Name	Part Image
3	Manual	
1	Soundproof/insulation sheath	
1	Outlet pipe sheath	
2	Outlet pipe clasp	
1	Drain joint	
1	Seal ring (Not available for the outdoor unit with dimensions of 38.58 in.* 38.39 in.*16.34 in.)	
1	Conduit installation plate	
1	Installation plate	
1	Remote control	
2	Battery	
1	Magnetic ring	
2	Copper nut	
3	Rubber ring	

## Optional Accessories

There are two types of remote controls: wired and wireless. Select a remote control based on customer preferences and requirements and install it in an appropriate place. Refer to catalogs and technical literature for guidance on selecting a suitable remote control.

**Table A-2: Optional Accessories**

QTY.	Part Name	Part Image
1	Wired control	
1	Remote control holder	
2	Screw for remote controller holder	

**Table A-3: Pipe Specification**

Model	Liquid Side	Gas Side
18K	Ø1/4 in. (Ø6.35 mm)	Ø1/2 in. (Ø12.7 mm)
24K	Ø3/8 in. (Ø9.52 mm)	Ø5/8 in. (Ø16 mm)
36K	Ø3/8 in. (Ø9.52 mm)	Ø3/4 in. (Ø19 mm)
48K	Ø3/8 in. (Ø9.52 mm)	Ø3/4 in. (Ø19 mm)
60K	Ø3/8 in. (Ø9.52 mm)	Ø3/4 in. (Ø19 mm)

Pipes are not included in the accessories and you need to purchase them separately from the local dealer.

## Unpacking

Carefully unpack the unit and inspect the contents for damage. If any damage is found at the time of delivery, proper notification and claims should be made with the carrier. Check the rating plate to ensure the model number and voltage, plus any kits match with what you ordered. The manufacturer should be notified within 5 days of any discrepancy or parts shortage.

### Indoor unit:

1. Cut the packing belt.
2. Unpack the package.
3. Take out the packing cushion and packing support.
4. Remove the packing film.
5. Take out the accessories.
6. Lift the machine out and lay it flat.

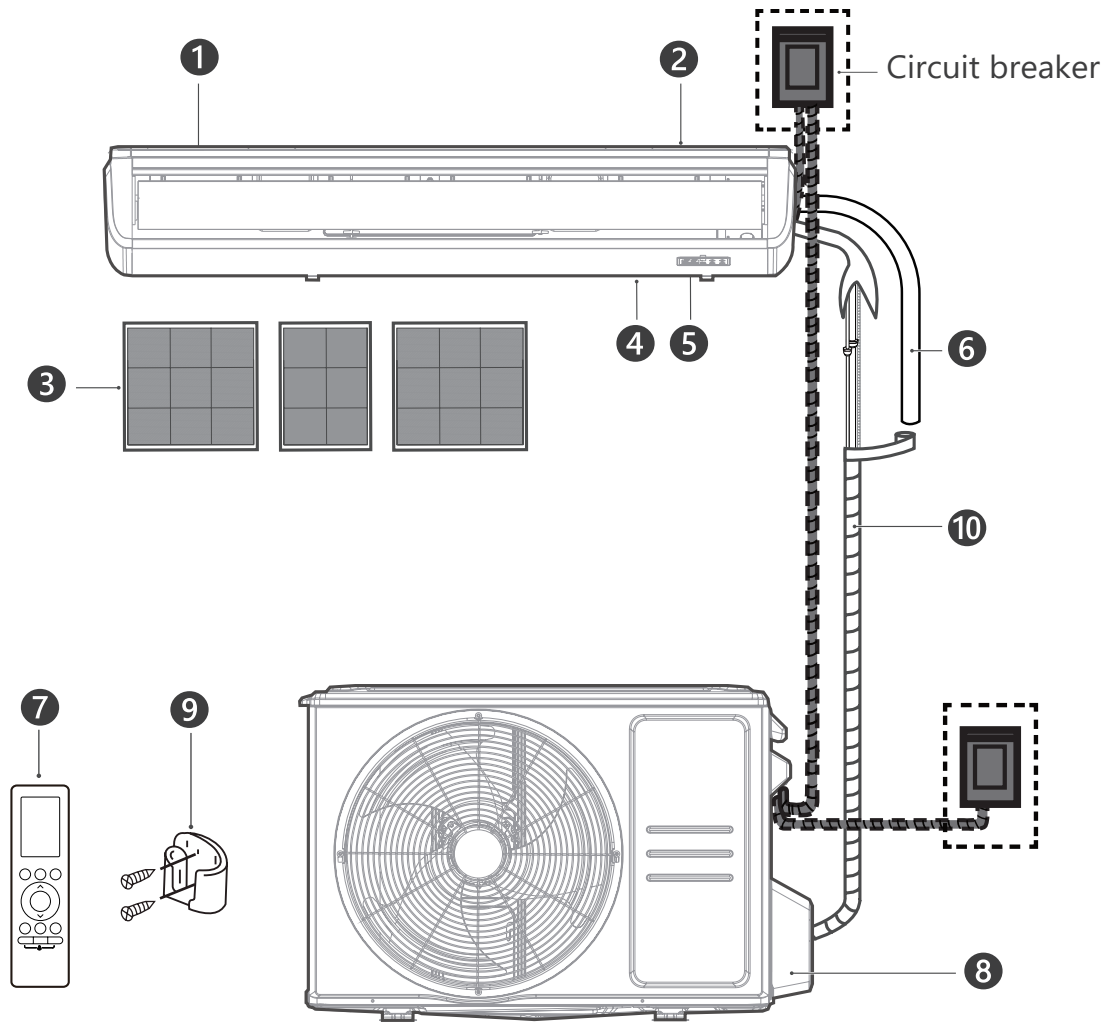
### Outdoor Unit:

1. Cut the packing belt.
2. Take the unit out of the package.
3. Remove the foam from the unit.
4. Remove the packing film from the unit.

### NOTE

Please keep all packaging items if you may need them in the future.

# Product Overview



1 Airflow louver (air outlet)

2 Installation part

3 Air filter

4 Air inlet (with air filter in it)

5 Display panel

6 Drainpipe

7 Remote Control

8 Outdoor Unit

9 Remote control holder (purchased separately)

10 Refrigerant piping (purchased separately)

## NOTE

Illustrations in this manual are for explanatory purposes. The actual shape of your indoor unit may be slightly different. The actual shape shall prevail.

# Dimensions & Clearances

Recommended distances between the indoor unit and the ceiling

The distance between the mounted indoor unit and the internal ceiling should meet the following specifications.

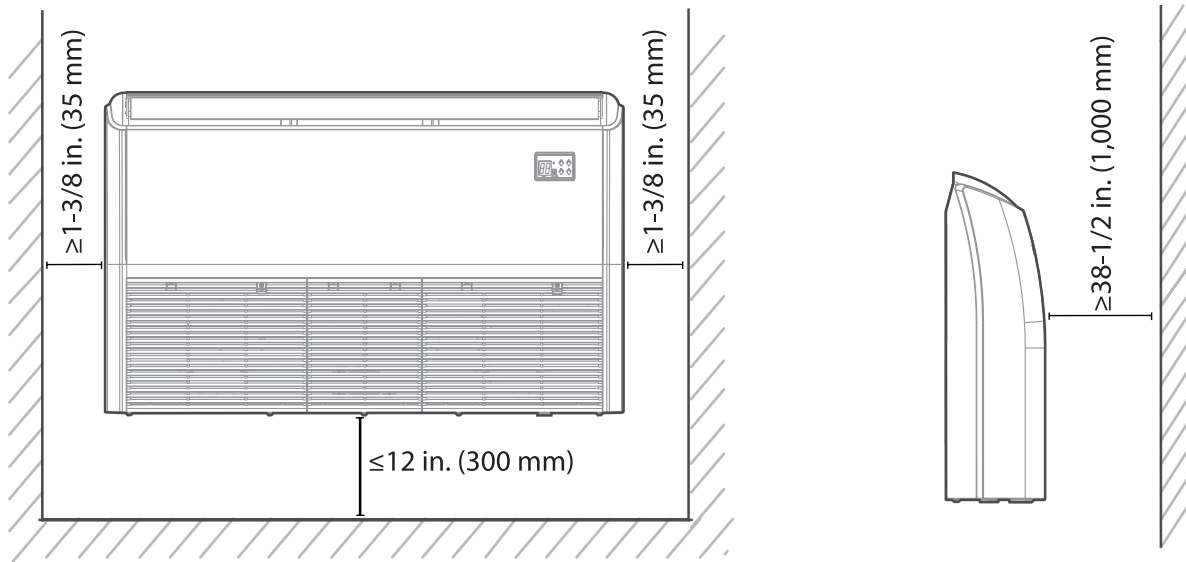


Fig. D-1: Unit Clearances

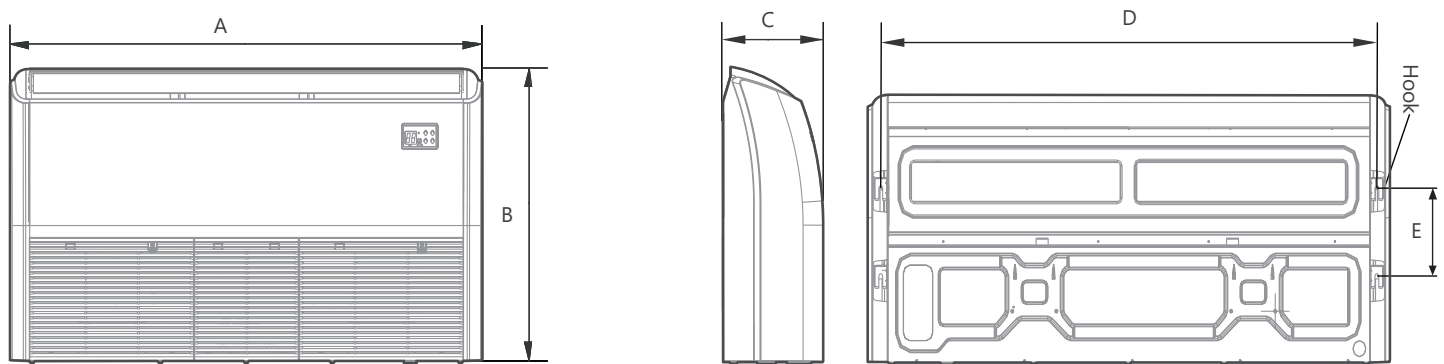


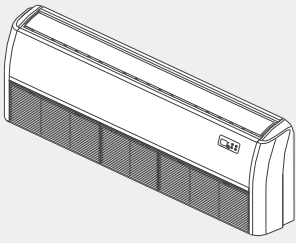
Fig. D-2: Unit Dimensions

Table D-1: Unit Dimensions

MODEL (Btu/h)	Length of A (inch/mm)	Length of B (inch/mm)	Length of C (inch/mm)	Length of D (inch/mm)	Length of E (inch/mm)
18K~24K	42/1068	26.6/675	9.3/235	38.7/983	8.7/220
36K~60K	65/1650	26.6/675	9.3/235	61.6/1565	8.7/220

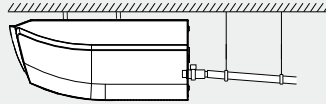
# Installation Summary

1



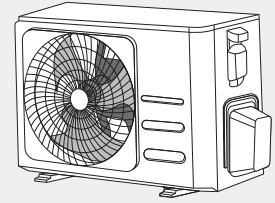
Install the indoor unit

2



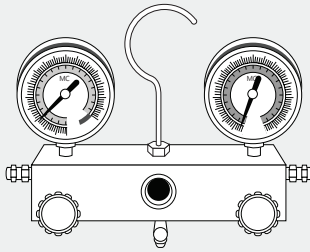
Install the drainpipe

3



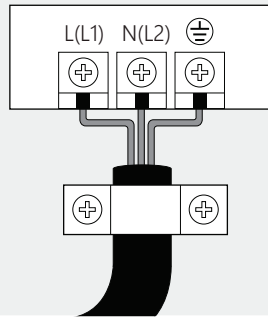
Install the outdoor unit

6



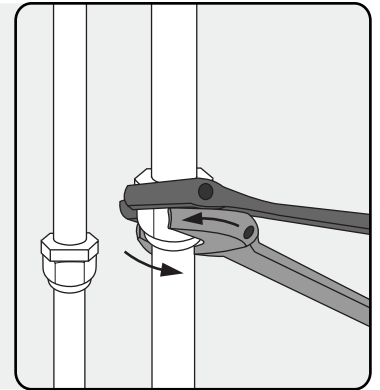
Evacuate the refrigeration system

5



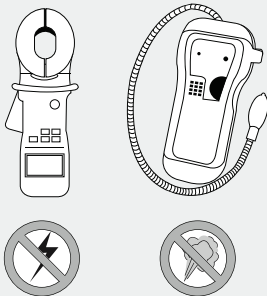
Connect the wires

4



Connect the refrigerant pipes

7



Perform a test run

# Installation Requirements

## NOTE

Before installing the indoor unit, you must choose an appropriate location. The following are standards that will help you choose an appropriate location for the unit.

## ⚠ WARNING

### DO NOT INSTALL IN THE FOLLOWING LOCATIONS:



- Rooms with high humidity, such as bathrooms or laundry rooms
- Areas with caustic gases in the air, such as hot springs.



- Areas with strong electromagnetic waves.
- Areas that experience power fluctuations, such as factories



- Coastal areas with high salt content in the air.



- Areas with oil drilling or fracking.



- Areas that store flammable materials or gas.
- Kitchens that use natural gas



- Areas where there may be detergent or other corrosive gases in the air, such as bathrooms, or laundry rooms.



- Areas where the air inlet and outlet may be obstructed.
- Enclosed spaces, such as cabinets



- The danger of explosion. Keep flammable materials and vapors, such as gasoline, away from the air handler.

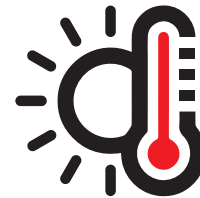
## ⚠ WARNING

THE UNIT MUST BE INSTALLED IN A LOCATION THAT MEETS THE FOLLOWING REQUIREMENTS:



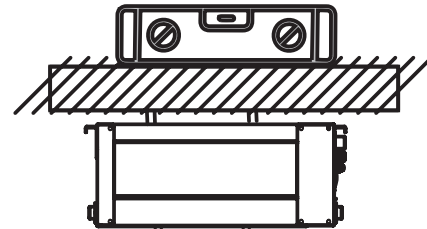
### Ample Room

- Enough room for installation and maintenance.
- Enough room for the connecting pipe and drainpipe.



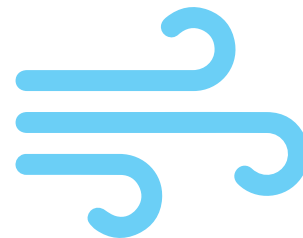
### Away From Heat

There is no direct radiation from heaters.



### Must Support the Weight of the Indoor Unit

The ceiling is horizontal, and its structure can sustain the weight of the indoor unit.



### Unrestricted Airflow

The air inlet and outlet are not blocked.

# Indoor Installation

## Step 1 - Hang The Indoor Unit

### Ceiling Installation

#### Wooden Structure Installation

1. Place the wood mounting across the roof beam, then install the hanging screw bolts.

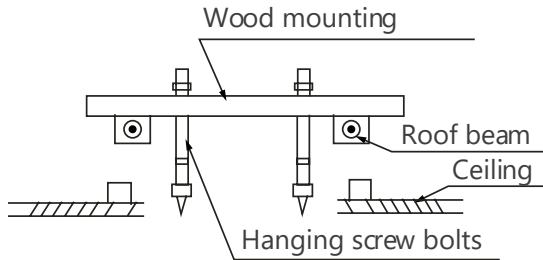


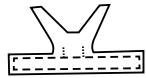
Fig. 1-1: Install Bolts Into Wood Mounting

#### New Concrete Bricks

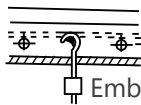
1. Inlay or embed the screw bolts.



(Blade shape insertion)



(Slide insertion)



Steel bar

Embedding screw bolt

(Pipe hanging and embedding screw bolt)

Fig. 1-2: Embed Screw Bolts In Concrete

#### Existing Concrete Bricks

1. Install the hanging hook with an expandable bolt into the concrete to a depth of 17-3/4 in.~19-3/4 in. (45~50 mm) to prevent loosening.

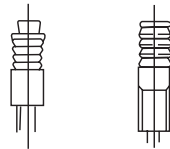


Fig. 1-3: Use Expandable Bolts

#### Steel Roof Beam Structure

1. Install and use the supporting steel angle.

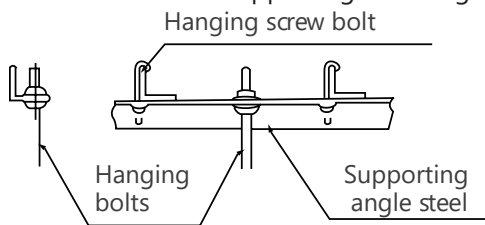


Fig. 1-4: Install Bolts Into Angle Steel

### ⚠ CAUTION

The unit body must be completely aligned with the hole. Ensure that the unit and the hole are the same size before moving on.

2. 1. Install and fit pipes and wires after you have finished installing the main body. When choosing where to start, determine the direction of the pipes to be drawn out. Especially in cases where there is a ceiling involved, align the refrigerant pipes, drain pipes, and indoor and outdoor lines with their connection points before mounting the unit.
3. The installation of hanging screw bolts.
  - Cut off the roof beam.
  - Strengthen the area at which the cut was made and consolidate the roof beam.
4. After the selection of the installation location, position the refrigerant pipes, drain pipes, and indoor and outdoor wires to the connection points before mounting the machine.
5. Drill 4 holes 4 in. (10 cm) deep at the ceiling hook positions in the internal ceiling. Be sure to hold the drill at a 90° angle to the ceiling.
6. Secure the bolt using the included washers and nuts.
7. Install the four suspension bolts.
8. Mount the indoor unit. You will need two people to lift and secure it. Insert suspension bolts into the unit's hanging holes. Fasten them using the included washers and nuts.

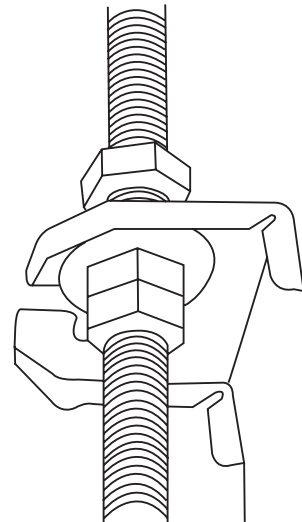
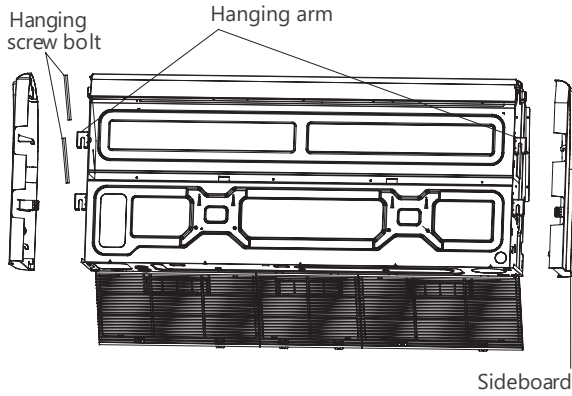


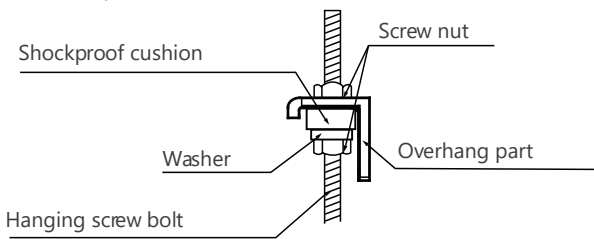
Fig. 1-5: Hang Unit Using Suspension Bolts

9. Remove the sideboard and the grille.



**Fig. 1-6: Expose The Hanging Arms**

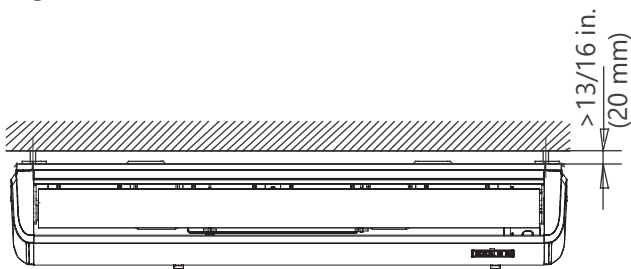
10. Mount the indoor unit onto the hanging screw bolts with a block. Position the indoor unit on a flat level by using a level to prevent leaks.



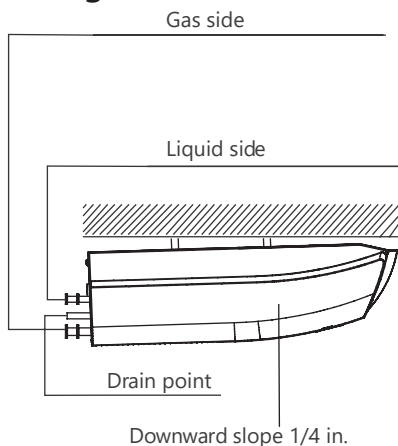
**Fig. 1-7: Hanging Bolt Arrangement**

**NOTE**

Confirm the minimum drain tilt is 1/4 in. or more.  
**Ceiling Installation**



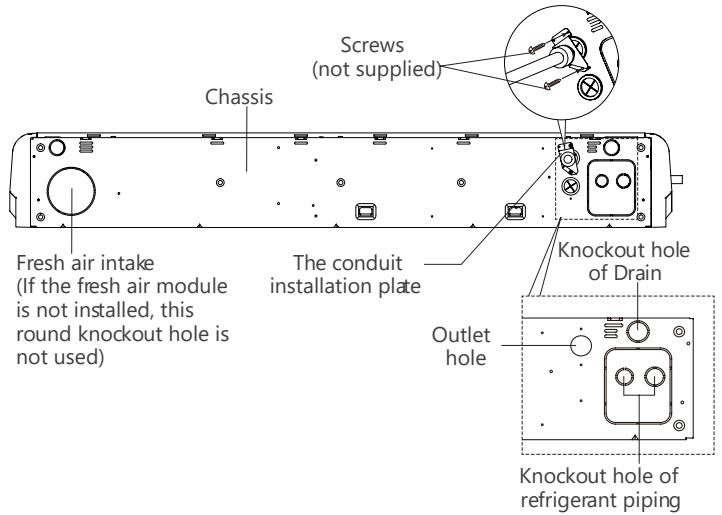
**Fig. 1-8: Leave Enough Space Between The Unit And Ceiling**



**Fig. 1-9: Ceiling-Mount Piping Arrangement**  
Ceiling & Floor Air Conditioner

**How To Install The Conduit Installation Plate**  
(if supplied)

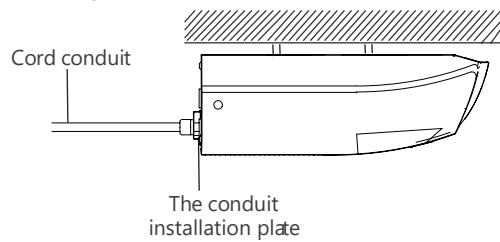
1. Attach the sheath connector of the conduit (not supplied) to the wire hole of the conduit installation plate.
2. Attach the conduit installation plate on the chassis of the unit.



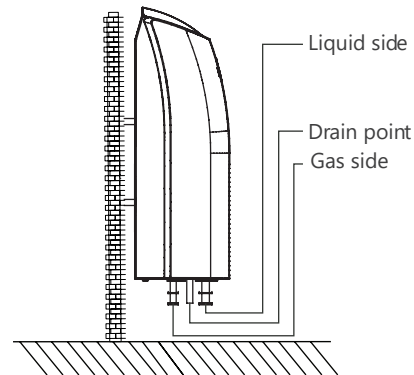
**Fig. 1-10: Conduit Plate Installation**

**NOTE**

When installing, open the corresponding round knockout holes as shown in the illustration, rectangular knockout holes are not permitted.



**Fig. 1-11: Cord Conduit Attached To Unit**  
**Wall-Mounted Installation**



**Fig. 1-12: Wall-Mount Piping Arrangement**

1. See "How To Install The Conduit Installation Plate" section and Fig. 1-10 for conduit plate installation.

## The Wiring Hole

1. Rubber rings are used to block the excess space in the three crossing holes of the electronic control box.

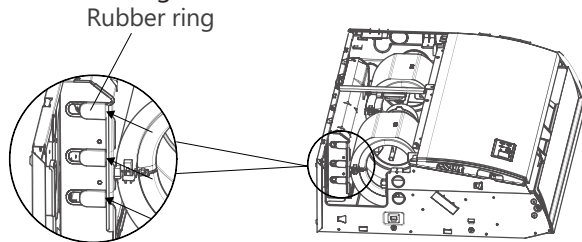


Fig. 1-13: Rubber Rings Location

2. The installation plate is designed to cover the outlet holes at the bottom of the base when they are not in use.

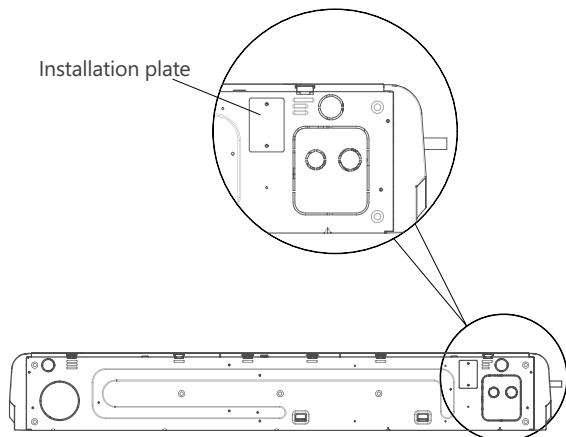


Fig. 1-14: Installation Plate Location

## Step 2 - Drill The Wall

1. Determine the location of the wall hole based on the location of the outdoor unit.
2. Drill a hole in the wall, 9K, 12K, 18K model using a 2-1/2 in. (65 mm) core drill, 24K, 36K, 48K model using a 3-1/2 in. (90 mm) core drill. Make sure that the hole is drilled at a slight downward angle, so that the outdoor end of the hole is lower than the indoor end by about 0.5in (12mm). This will ensure proper water drainage.
3. Place the protective wall cuff in the hole. This protects the edges of the hole and will help seal it when you finish the installation process

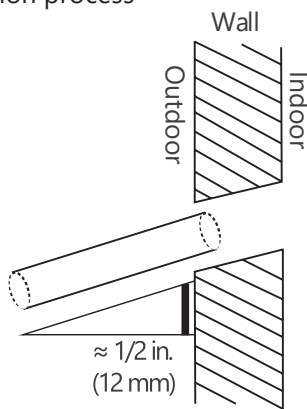


Fig. 2-1: Drill The Wall Hole At An Angle

## ⚠ CAUTION

When drilling the wall hole, make sure to avoid wires, plumbing, and other sensitive components.

## Step 3 - Connect Drain Hose

The drainpipe is used to drain water away from the unit. Improper installation may cause unit and property damage.

## ⚠ CAUTION

- Insulate all piping to prevent condensation, which could lead to water damage.
- If the drainpipe is bent or installed incorrectly, water may leak and cause a water-level switch malfunction.
- In **HEAT** mode, the outdoor unit will discharge water. Ensure that the drain hose is placed in an appropriate area to avoid water damage and slippage.
- **DO NOT** pull the drainpipe forcefully. This could disconnect it.

## NOTE

### On Purchasing Pipes

Installation requires a polyethylene tube (exterior diameter = 1-1/2-1-5/8 in. (3.7-3.9 cm), interior diameter = 1-1/4 in. (3.2 cm), which can be obtained at your local hardware store or dealer.

### Indoor Drainpipe Installation

1. Install the drainpipe as illustrated in Fig. 3-1.

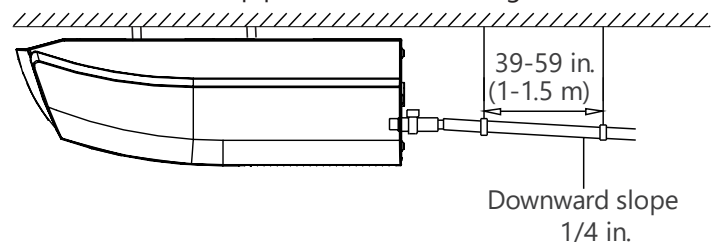
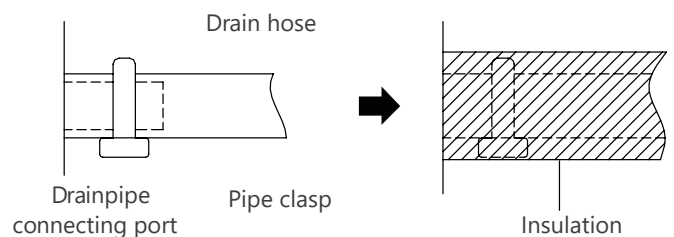


Fig. 3-1: Drainpipe Connection

2. Cover the drainpipe with heat insulation to prevent condensation and leakage.
3. Attach the mouth of the drain hose to the unit's outlet pipe. Sheath the mouth of the hose and clip it firmly with a pipe clasp.

Fig. 3-3: Install Drainpipe Insulation



## NOTE

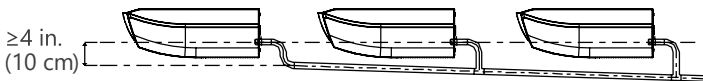
- When using an extended drainpipe, tighten the indoor connection with an additional protection tube to prevent it from pulling loose.
- The drainpipe should slope downward at a gradient of

at least ¼ in. to prevent water from flowing back into the air conditioner.

- To prevent the pipe from sagging, space hanging wires every 39-59 in. (1-1.5 m).
- Incorrect installation could cause water to flow back into the unit and flood.

**NOTE**

When connecting multiple drainpipes, install the pipes as illustrated in Figure 3-2.



**Fig. 3-3: Multi-Unit Drainpipe Arrangement**

4. Pass the drain hose through the wall hole. Make sure the water drains to a safe location where it will not cause water damage or a slipping hazard.

**NOTE**

The drainpipe outlet should be at least 2 in. (5 cm) above the ground. If it touches the ground, the unit may become blocked and malfunction. If you discharge the water directly into a sewer, make sure that the drain has a U or S pipe to catch odors that might otherwise come back into the house.

# Outdoor Installation

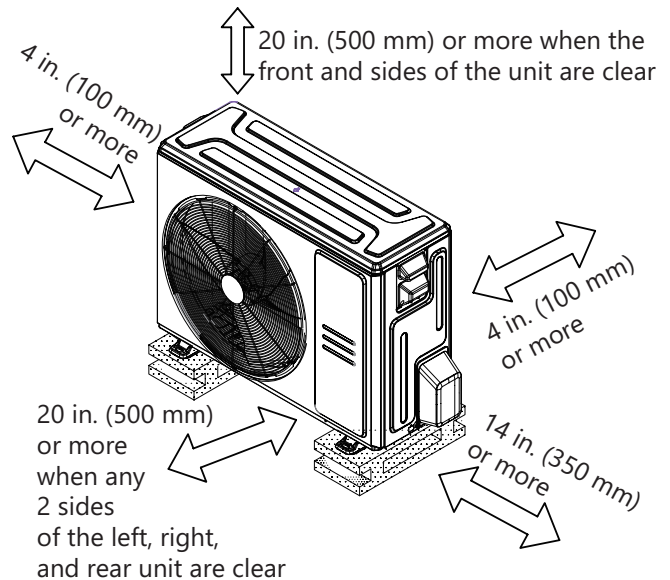
## Step 4 - Installation Location

**NOTE**

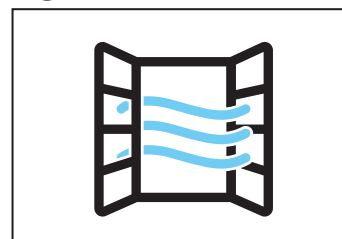
**BEFORE INSTALLATION**

Before installing the outdoor unit, you must choose an appropriate location. The following are standards that will help you choose an appropriate location for the unit.

**Proper installation locations must meet the following standards:**

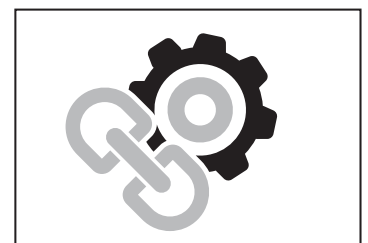


**Fig. 4-1: Clearance Dimensions**



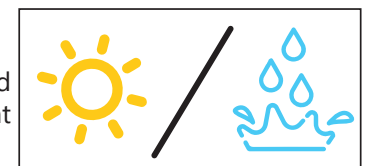
- Good air circulation and ventilation.

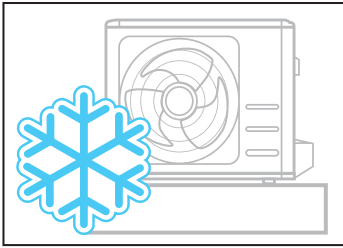
- Firm and solid - the location can support the unit and will not vibrate.



- Noise from the unit will not disturb other people.

- Protected from prolonged periods of direct sunlight or rain.





- Where snowfall is anticipated, take appropriate measures to prevent ice buildup and coil damage.

**CAUTION**

**SPECIAL CONSIDERATIONS FOR EXTREME WEATHER**

**If the unit is exposed to heavy wind:**

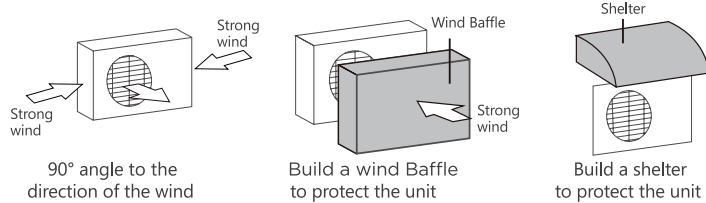
Install the unit so that the air outlet fan is at a 90° angle to the direction of the wind. If needed, build a barrier in front of the unit to protect it from extremely heavy winds. See Fig. 4-2.

**If the unit is frequently exposed to heavy rain or snow:**

Build a shelter above the unit to protect it from the rain or snow. Be careful not to obstruct airflow around the unit.

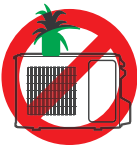


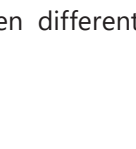
**If the unit is frequently exposed to salty air (seaside):**

Use an outdoor unit that is specially designed to resist corrosion.



**Fig. 4-2: High Wind Installation**

**DO NOT install the unit in the following locations:**

- Near an obstacle that will block air inlets and outlets. 
- Near animals or plants that will be harmed by hot air discharge. 
- Near a public street, crowded areas, or where noise from the unit will disturb others.
- Near any source of combustible gas. 
- In a location that is exposed to large amounts of dust.
- In a location exposed to excessive amounts of salty air. 

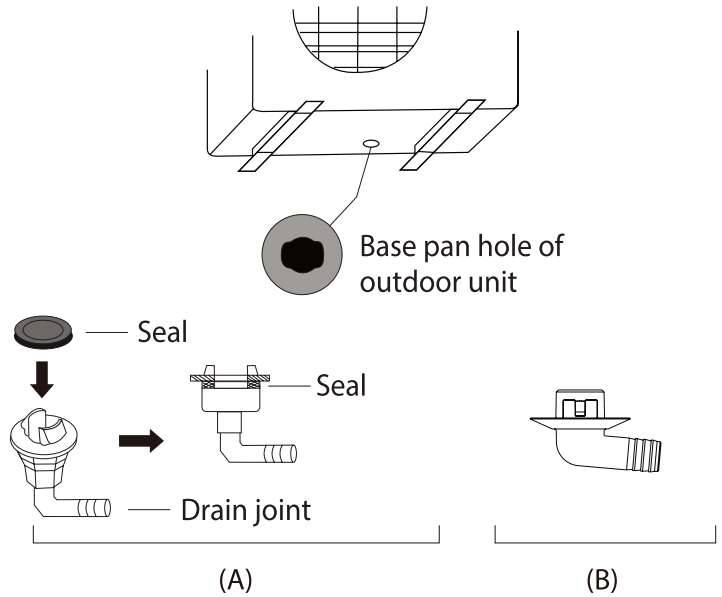
**NOTE**

Install the unit by following local codes and regulations, there may be differences between different regions.

**Step 5 - Install Drain Joint**

Before bolting the outdoor unit in place, you must install the drain joint at the bottom of the unit.

Note that there are two different types of drain joints depending on the type of outdoor unit



**Fig. 5-1: Drain Joint Types**

**If the drain joint comes with a rubber seal (A), do the following:**

1. Fit the rubber seal on the end of the drain joint that will connect to the outdoor unit.
2. Insert the drain joint into the hole in the base pan of the unit.
3. Rotate the drain joint 90° until it clicks in place facing the front of the unit.
4. Connect a drain hose extension (not included) to the drain joint to redirect water from the unit during heating mode.

**If the drain joint doesn't come with a rubber seal (B), do the following:**

1. Insert the drain joint into the hole in the base pan and press firmly to ensure it is properly installed and will not become loose.
2. Connect a drain hose extension (not included) to the drain joint to redirect water from the unit during heating mode.

**NOTE**

**IN COLD CLIMATES**

In cold climates, make sure that the drain hose is as vertical as possible to ensure swift water drainage. If water drains too slowly, it can freeze in the hose and flood the unit.

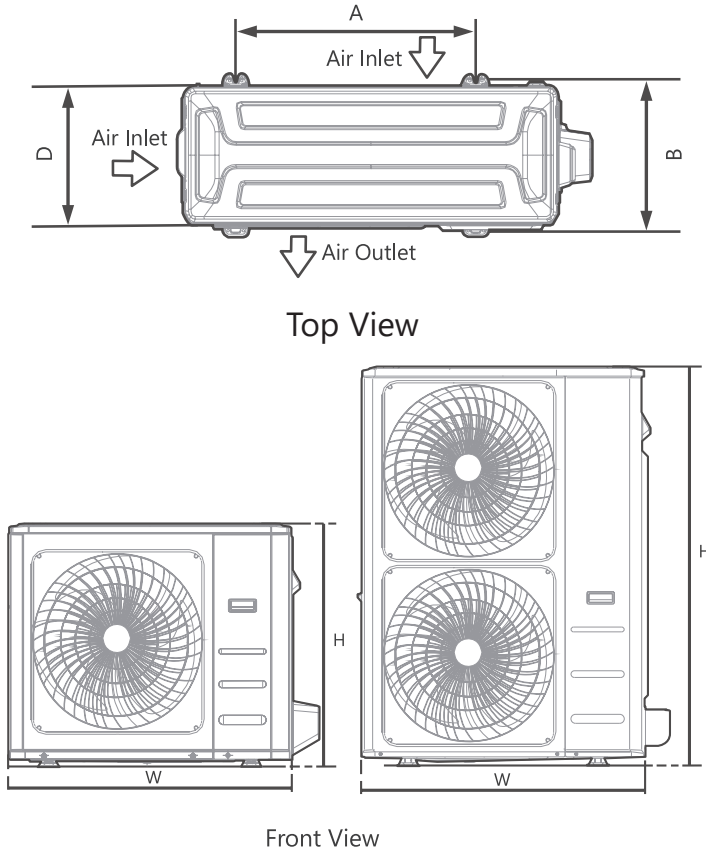
# Step 6 - Anchor Outdoor Unit

**WHEN DRILLING INTO CONCRETE, EYE PROTECTION IS RECOMMENDED AT ALL TIME.**

## ⚠ WARNING

- The outdoor unit can be anchored to the ground or to a wall-mounted bracket with bolt(M10). Prepare the installation base of the unit according to the dimensions in Table 6-1.

The following is a list of different outdoor unit sizes and the distance between their mounting feet. Prepare the installation base of the unit according to the dimensions in Table 6-1.



**Fig. 6-1: Unit Dimensions**

**Table 6-1: Outdoor Unit Dimensions**

Outdoor Unit Dimensions W x H x D	Mounting Dimensions	
	Distance A	Distance B
35 in. x 26-1/4 in. x 13-1/2 in. (890 mm x 673 mm x 342 mm)	26-1/8 in. (663 mm)	13-7/8 in. (354 mm)
37-1/4 in. x 31-7/8 in. x 16-1/2 in. (946 mm x 810 mm x 420 mm)	26-1/2 in. (673 mm)	15-7/8 in. (403 mm)
37-1/2 in. x 52-1/2 in. x 16-3/8 in. (952 mm x 1333 mm x 415 mm)	25 in. (634 mm)	15-7/8 in. (404 mm)
38-5/8 in. x 38-3/8 in. x 16-3/8 in. (980 mm x 975 mm x 415 mm)	24-1/4 in. (616 mm)	15-5/8 in. (397 mm)

**If you install the unit on the ground or a concrete mounting platform, do the following:**

1. Mark the positions for four expansion bolts based on the dimensions chart.

2. Pre-drill holes for expansion bolts.
3. Place a nut on the end of each expansion bolt.
4. Hammer expansion bolts into the pre-drilled holes.
5. Remove the nuts from the expansion bolts and place the outdoor unit on the bolts.
6. Put the washer on each expansion bolt, then replace the nuts.
7. Using a wrench, tighten each nut until it is snug.

**If you install the unit on a wall-mounted bracket, do the following:**

1. Mark the position of bracket holes based on the dimensions chart.
2. Pre-drill the holes for the expansion bolts.
3. Place a washer and nut on the end of each expansion bolt.
4. Thread expansion bolts through holes in mounting brackets, put mounting brackets in position, and hammer expansion bolts into the wall.
5. Check that the mounting brackets are level.
6. Carefully lift the unit and place its mounting feet on brackets.
7. Bolt the unit firmly onto the brackets.
8. If allowed, install the unit with rubber gaskets to reduce vibrations and noise.

**Make sure that the wall is made of solid brick, concrete, or similarly strong material. The wall must be able to support at least four times the weight of the unit.**

### Multiple Unit Installation

The relations between H, A, and L are as follows

**Table 6-2: Multiple Unit Clearances**

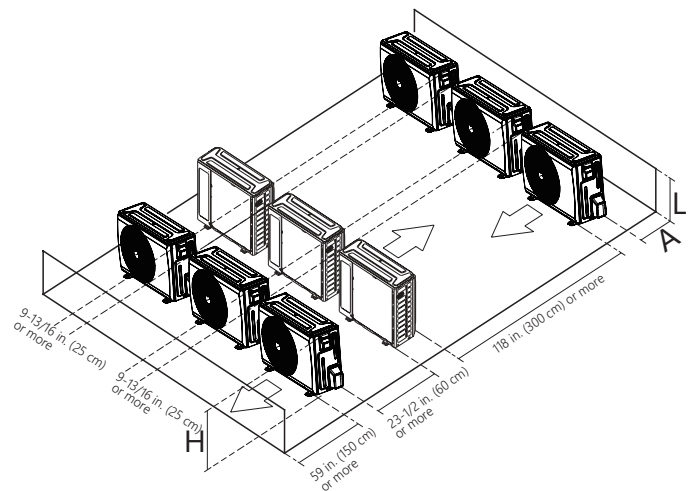
	L	A
L ≤ H	L ≤ 1/2 H	9-13/16 in. (25 cm) or more
	1/2 H < L ≤ H	11-13/16 in. (30 cm) or more
L > H	Cannot be installed.	

### NOTE

H=Unit height

L=Height of the wall behind the unit

A=Distance between the unit and the wall



**Fig. 6-2: Clearances for Multiple Units**

# Step 7 - Refrigerant Piping Connection

When connecting refrigerant piping, **DO NOT** let substances or gases other than the specified refrigerant enter the unit. The presence of other gases or substances will lower the unit's capacity, and can cause abnormally high pressure in the refrigeration cycle. This can cause explosion and injury.

**Table 7-1: Pipe Length & Elevation**

The maximum length and drop height based on models

Model	Length of Piping	Maximum Drop Height
18K	98-7/16 ft./30 m	65-5/8 ft./20 m
24K	164 ft./50 m	82 ft./25 m
36K/48K	246 ft./75 m	98-7/16 ft./30 m

Ensure that the length of the refrigerant pipe, the number of bends, and the drop height between the indoor and outdoor units meets the requirements shown in the table.

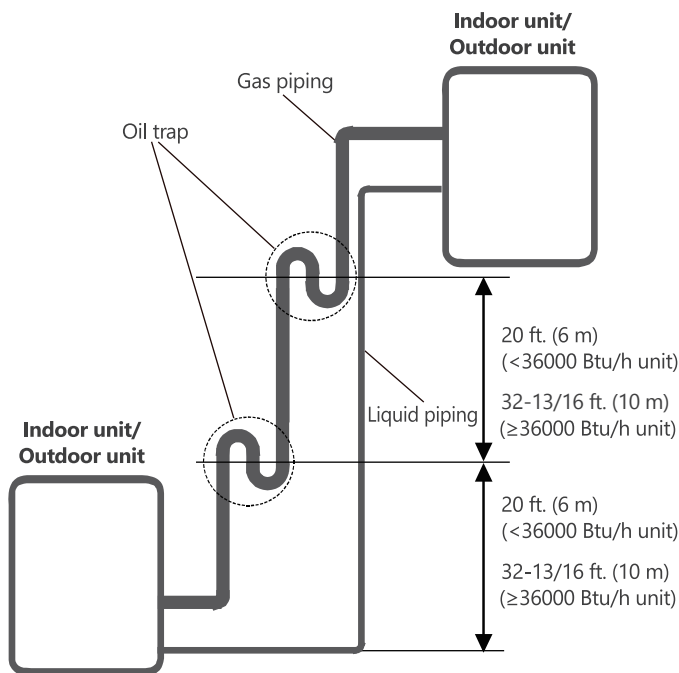
## ⚠ CAUTION

### Oil traps

If oil flows back into the outdoor unit's compressor, this might cause liquid compression or deterioration of oil return. Oil traps in the rising gas piping can prevent this from happening.

An oil trap should be installed every 20 ft. (6 m) of the vertical suction line riser (for units with a capacity of less than 36,000 Btu/h). An oil trap should be installed every 32-13/16 ft. (10 m) of vertical suction line riser ( $\geq 36000$  Btu/h unit).

**Fig. 7-1: Oil Trap Arrangement**



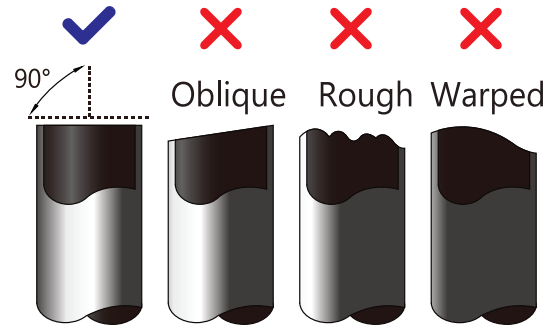
## ⚠ CAUTION

- The branching pipe must be installed horizontally. An angle of more than 10° may cause malfunction.
- **DO NOT** install the connecting pipe until both indoor and outdoor units have been installed.
- Insulate both the gas and liquid piping to prevent condensation.

### Cut pipes

When preparing refrigerant pipes, take extra care to cut and flare them properly. This will ensure efficient operation and minimize the need for future maintenance.

1. Measure the distance between the indoor and outdoor units.
2. Using a pipe cutter, cut the pipe a little longer than the measured distance.
3. Make sure the pipe is cut at a perfect 90° angle.



**Fig. 7-2: Correct Pipe Cutting**

### NOTE

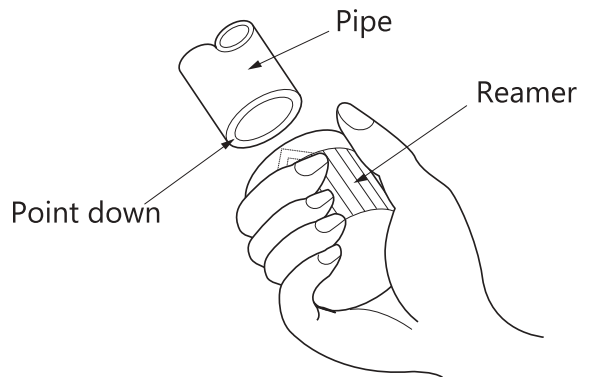
#### DO NOT DEFORM PIPE WHILE CUTTING

Be extra careful not to damage, dent, or deform the pipe while cutting. This will drastically reduce the heating efficiency of the unit.

4. Remove the Burrs

Burrs can affect the air-tight seal of the refrigerant piping connection. Therefore, they must be completely removed. To remove:

- a. Hold the pipe at a downward angle to prevent burrs from falling into the pipe.
- b. Using a reamer or deburring tool, remove all burrs from the cut section of the pipe

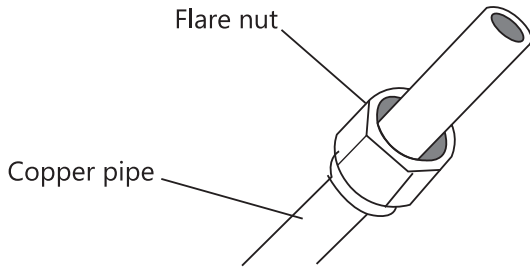


**Fig. 7-3: Reamer Tool**

5. Flare the Pipe Ends.

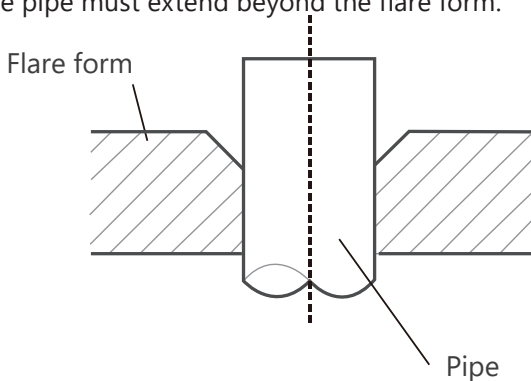
Proper flaring is essential to achieving an airtight seal.

- a. After removing the burrs from the cut pipe, seal the ends with PVC tape to prevent foreign materials from entering the pipe.
- b. Sheath the pipe with insulating material.
- c. Place the factory flare nut on the pipe facing the proper direction. Make sure they are facing the right direction. Once the ends are flared, it is impossible to put them on or change their direction.



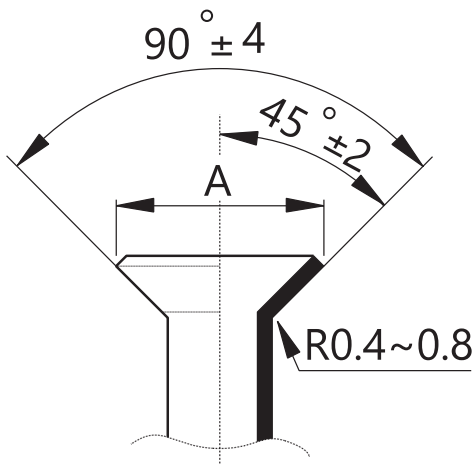
**Fig. 7-4: Copper pipe and flare nut**

- d. Remove the PVC tape from the ends of the pipe when ready to perform the flaring work.
- e. Clamp the flare block on the end of the pipe. The end of the pipe must extend beyond the flare form.



**Fig. 7-5: Flare Form**

- f. Place the flaring tool onto the form.
- g. Turn the handle of the flaring tool clockwise until the pipe is fully flared. Flare the pipe following the dimensions in Table 7-2.



**Fig. 7-6: Flare Shape**

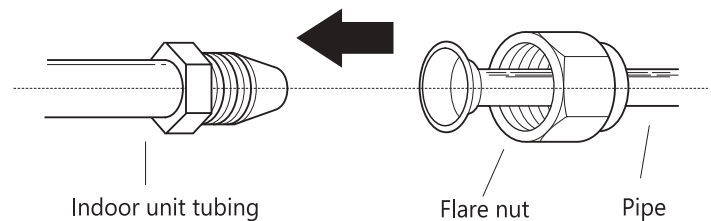
**Table 7-2: Flare Dimensions/Tightening Torque**

Pipe Size Outside Diameter	Flare Dimensions (A)
in. (mm)	in. (mm)
Ø1/4 (6.35)	11/23 - 23/64 (~9.1)
Ø3/8 (9.52)	1/2 - 33/64 (~13.2)
Ø1/2 (12.7)	41/64 - 31/32 (~16.6)

Tightening Torque for Flare Nuts

Pipe Size Outside Diameter	Tightening Torque
in. (mm)	ft. - lbs.
Ø1/4 (6.35)	13.0 - 18.0
Ø3/8 (9.52)	24.6 - 30.4
Ø1/2 (12.7)	39.8 - 47.7

- h. Remove the flaring tool and flare block, then inspect the end of the pipe for cracks and even flaring.
6. Connect the Pipes
- Connect the copper pipes to the indoor unit first, then connect the pipes to the outdoor unit. Connect the low-pressure pipe first, then connect the high-pressure pipe.
- a. Align the center of the two pipes that you will connect.

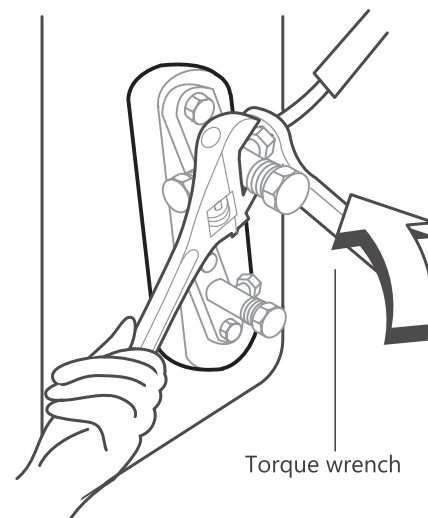


**Fig. 7-7: Align the center of the two pipes**

- b. Tighten the flare nut as much as possible by hand.
- c. Using a wrench, grip the nut on the unit tubing.
- d. While firmly gripping the nut, use a torque wrench to tighten the flare nut according to the torque values listed in Table 7-2.

**NOTE**

Use both a spanner and a torque wrench when connecting or disconnecting pipes to/from the unit.



**Fig. 7-8: Spanner and Torque Wrench**

All tubing bends should be performed with a properly sized tubing bender to prevent kinking or damaging the tubing.

- e. While firmly gripping the nut, use a torque wrench to tighten the flare nut according to the torque values listed in Table 7-2.

### CAUTION

Ensure to wrap insulation around the piping. Direct contact with the bare piping may result in burns or frostbite.

- Make sure the pipe is properly connected.
- Over-tightening may damage the bell mouth and under-tightening may lead to leakage.

### NOTE

#### MINIMUM BEND RADIUS

Carefully bend the tubing in the middle according to the diagram below. DO NOT bend the tubing over 90° or more than 3 times. Use care when bending pipe, do not kink pipe.

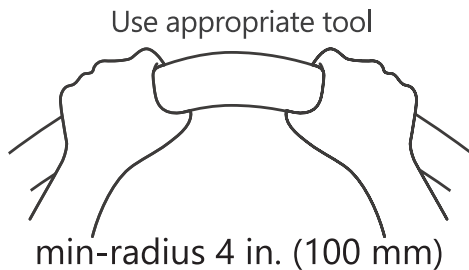


Fig. 7-9: Bend the Tubing

- f. After connecting the copper pipes to the indoor unit, wrap the power cable, signal cable, and piping together with binding tape.

### NOTE

DO NOT intertwine the signal cable with other wires. While bundling these items together. DO NOT intertwine or cross the signal cable with any other wiring.

## Step 8 - Outdoor Unit Wiring

### WARNING

**BEFORE PERFORMING ANY ELECTRICAL WORK, READ THESE WARNINGS.**

- All wiring must comply with local and national electrical codes and regulations and must be installed by a licensed electrician.
- All electrical connections must be made according to the Electrical Connection Diagram located on the panels of the indoor and outdoor units.
- If there is a serious safety issue with the power supply, stop work immediately. Explain your reasoning to the client and refuse to install the unit until the safety issue is properly resolved.
- Power voltage should be within 90-110% of rated voltage. Insufficient power supply can cause malfunction, electrical shock, or fire.

- Installation of an external surge suppressor at the outdoor disconnect is recommended.
- If connecting power to fixed wiring, a switch or circuit breaker that disconnects all poles and has a contact separation of at least 1/8in (3mm) must be incorporated into the fixed wiring. The qualified technician must use an approved circuit breaker or switch.
- Only connect the unit to an individual branch circuit. Do not connect another appliance to that outlet.
- Make sure to properly ground the air conditioner.
- Every wire must be firmly connected. Loose wiring can cause the terminal to overheat, resulting in product malfunction and possible fire.
- Do not let wires touch or rest against refrigerant tubing, the compressor, or any moving parts within the unit.
- If the unit has an auxiliary electric heater, it must be installed at least 40 in. (1 m) away from any combustible materials.
- To avoid getting an electric shock, never touch the electrical components soon after the power supply has been turned off. After turning off the power, always wait 10 minutes or more before you touch the electrical components.
- Make sure that you do not cross your electrical wiring with your signal wiring.
- This may cause distortion, interference, or possibly damage to circuit boards.
- No other equipment should be connected to the same power circuit.
- Connect the outdoor wires before connecting the indoor wires.

### WARNING

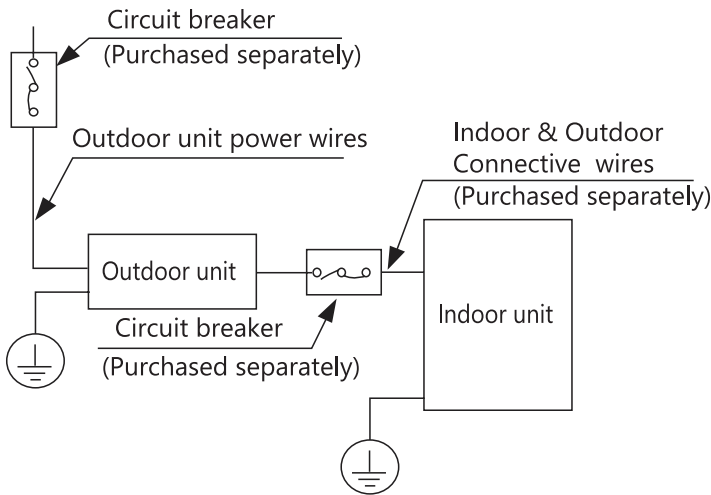
**BEFORE PERFORMING ANY ELECTRICAL OR WIRING WORK, TURN OFF THE MAIN POWER TO THE SYSTEM.**

### NOTE

#### On Circuit Breaker

When the maximum current of the air conditioner is more than 16 A, a circuit breaker or leakage protection switch with a protective device shall be used (purchased separately). When the maximum current of the air conditioner is less than 16 A, the power cord of the air conditioner shall be equipped with a plug (purchased separately). In North America, the application should be wired according to NEC and CEC requirements.

**Fig. 8-1: Wiring Overview**



**NOTE**

The diagrams are for explanation purposes only. Your machine may be slightly different. The actual diagram shall prevail.

**⚠ WARNING**

**Outdoor Unit Wiring**

Before performing any electrical or wiring work, turn off the main power to the system.

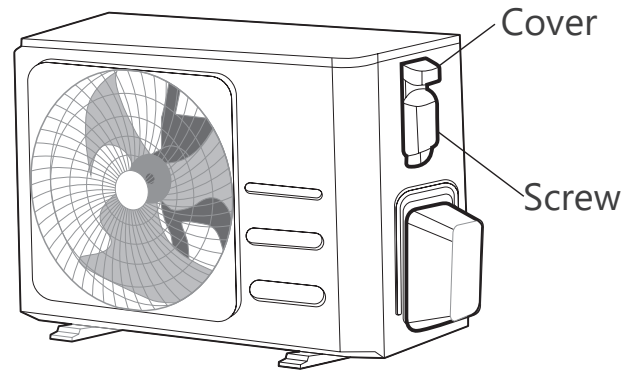
**Prepare the cable for connection.**

1. You must first choose the right cable size. Choose the cable type according to the local electrical codes and regulations.
2. The size of the power supply cable, signal cable, fuse, and switch needed is determined by the Minimum Circuit Ampacity of the unit. The Minimum Circuit Ampacity is indicated on the nameplate located on the side panel of the unit. Refer to this nameplate to choose the right cable, fuse, or switch.
3. Using wire strippers, strip the insulating jacket from both ends of the signal cable to reveal about 6 in. (150 mm) of the wire.
4. Strip the insulation from the ends of the wires.
5. Using a wire crimper, crimp u-lugs on the ends.

**NOTE**

When connecting the wires, strictly follow the wiring diagram found inside the electrical box cover.

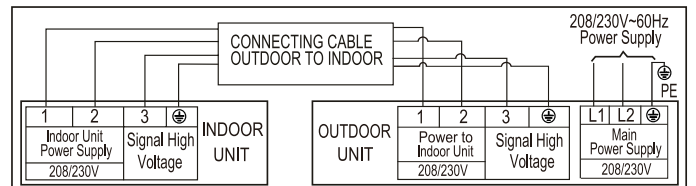
6. Remove the electric cover of the outdoor unit. If there is no cover on the outdoor unit, take off the bolts from the maintenance board and remove the protection board.



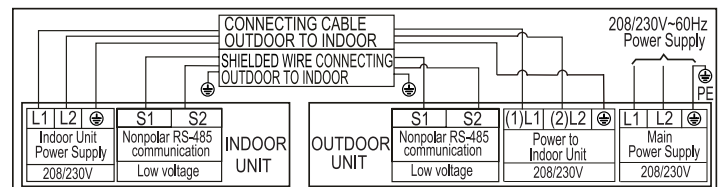
**Fig. 8-2: Remove Electrical Cover**

**Connect the wires to the terminals.**

7. Match the wire colors/labels with the labels on the terminal block. Firmly screw the u-lug of each wire to its corresponding terminal..
8. Clamp down the cable with the cable clamp.
9. Insulate unused wires with electrical tape. Keep them away from any electrical or metal parts.
10. Reinstall the cover of the electric control box.



**Connection Diagram (18K/24K)**



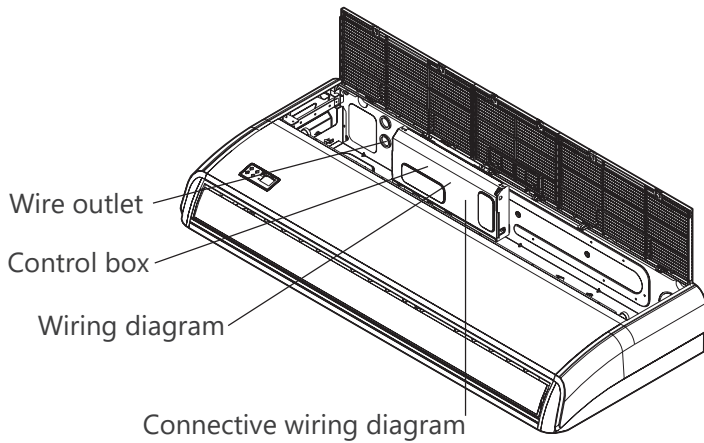
**Connection Diagram (36K/48K/60K)**

**Fig. 8-3: Connection Diagram**

**Indoor Unit Wiring**

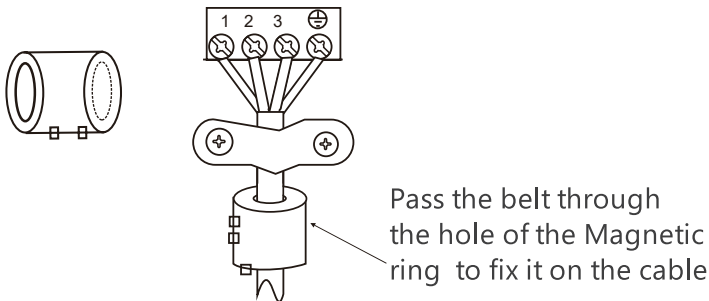
**Prepare the cable for connection.**

1. Using wire strippers, strip the rubber jacket from both ends of the signal cable to reveal approximately 6 in. (150mm) of wire.
2. Strip the insulation from the ends.
3. Using a wire crimper, crimp the u-lugs to the ends of the wires.
4. Open the front panel of the indoor unit. Using a screwdriver, remove the cover of the electric control box from your indoor unit.
5. Thread the power cable and the signal cable through the wire outlet.
6. Connect the U-lugs to the terminals. Match the wire colors/labels with the labels on the terminal block. Firmly screw the u-lug of each wire to its corresponding terminal. Refer to the Serial Number and Wiring Diagram located on the cover of the electric control box.



**Fig. 8-4: Super-Slim Models**

Magnetic ring (if supplied and packed with accessories).



**Fig. 8-5: Magnetic Ring Installation**

**CAUTION**

- When connecting the wires, strictly follow the wiring diagram found inside the electrical box cover.
- The refrigerant circuit can become very hot. Keep the interconnection cable away from the copper tube.
- 7. Clamp down the cable with the cable clamp. The cable must not be loose or pull on the U-lugs.
- 8. Reattach the electric box cover.

## Step 9 - Air Evacuation

**NOTE**

When opening valve stems, turn the hexagonal wrench until it hits the stopper. Do not try to force the valve to open further.

Open valves slowly until you hear refrigerant, and allow pressure to equalize before opening fully. Open the large vapor line valve first.

**PREPARATIONS AND PRECAUTIONS**

Air and foreign matter in the refrigerant circuit can cause abnormal rises in pressure, which can damage the air conditioner, reduce its efficiency, and cause injury. Use a vacuum pump and manifold gauge to evacuate the refrigerant circuit, removing any non-condensable gas and moisture from the system. Evacuation should be performed upon initial installation and when the unit is relocated.

**CAUTION**

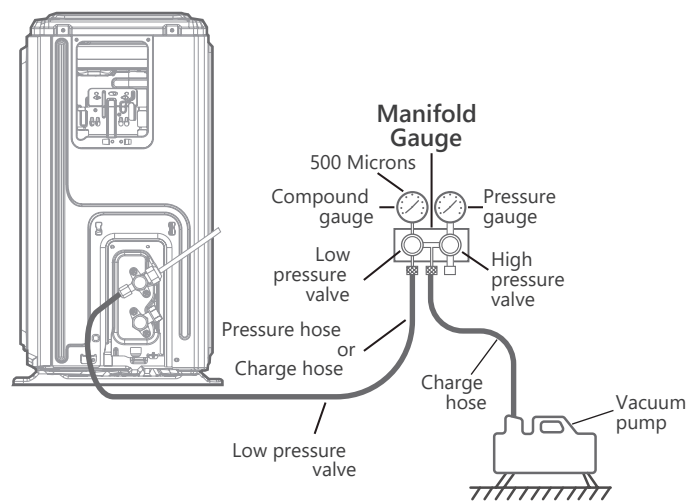
**BEFORE PERFORMING EVACUATION**

- Check to make sure the connective pipes between the indoor and outdoor units are connected properly.
- Check to make sure all wiring is connected properly.

**Evacuation Instructions**

1. Connect the charge hose of the manifold gauge to the service port on the outdoor unit's low pressure valve.
2. Connect another charge hose from the manifold gauge to the vacuum pump.
3. Open the Low-Pressure side of the manifold gauge. Keep the High-Pressure side closed.
4. Tighten refrigerant valve caps hand-tight plus flat to ensure there are no vacuum leaks.

**Outdoor unit**



**Fig. 9-1: Manifold Gauge Arrangement**

5. Turn on the vacuum pump to evacuate the system.
6. Run the vacuum for at least 15 minutes, or until the Compound Meter reads 500 microns.
7. Close the Low-Pressure side of the manifold gauge and turn off the vacuum pump.
8. Wait for 5 minutes, then check that there has been no change in system pressure.
9. If there is a change in system pressure, refer to the Gas Leak Check section for information on how to check for leaks. If there is no change in system pressure, unscrew the cap from the packed valve (high-pressure valve).
10. Insert a hexagonal wrench into the packed valve (high-pressure valve) and open the valve by turning the wrench in a 1/4 counterclockwise turn. Listen for gas to exit the system, then close the valve after 5 seconds.
11. Watch the Pressure Gauge for one minute to make sure that there is no change in pressure. The Pressure Gauge should read slightly higher than atmospheric pressure.
12. Remove the charge hose from the service port.

# Test Run

## ⚠ CAUTION

Failure to perform the test run may result in unit damage, property damage, or personal injury.

### Before the Test Run

A test run must be performed after the entire system has been completely installed. Confirm the following points before performing the test:

- Indoor and outdoor units are properly installed.
- Piping and wiring are properly connected.
- No obstacles near the inlet and outlet of the unit that might cause poor performance or product malfunction.
- The refrigeration system does not leak.
- The drainage system is unimpeded and draining to a safe location.
- Heating insulation is properly installed.
- Grounding wires are properly connected.
- Length of the piping and additional refrigerant capacity have been recorded.
- Power voltage is the correct voltage for the air conditioner

### Test run Instructions

- Open both the liquid and gas service valves.
- Turn on the main power switch and allow the unit to warm up.
- Set the air conditioner to COOL mode.
- For the Indoor Unit
  - Ensure the remote control and its buttons work properly.
  - Ensure the louvers move properly and can be changed using the remote control.
  - Double check to see if the room temperature is being registered correctly.
  - Ensure the indicators on the remote control and the display panel on the indoor unit work properly.
  - Ensure the manual buttons on the indoor unit work properly.
  - Check to see that the drainage system is unimpeded and draining smoothly.
  - Ensure there is no vibration or abnormal noise during operation.
- For the Outdoor Unit
  - Check to see if the refrigeration system is leaking.
  - Make sure there is no vibration or abnormal noise during operation.
  - Ensure the wind, noise, and water generated by the unit do not disturb your neighbors or pose a safety hazard.
- Drainage Test
  - Ensure the drainpipe flows smoothly. New buildings should perform this test before finishing the ceiling.
  - Remove the test cover. Add 2,000ml of water to the tank through the attached tube.
  - Turn on the main power switch and run the air conditioner in COOL mode.
  - Listen to the sound of the drain pump to see if it

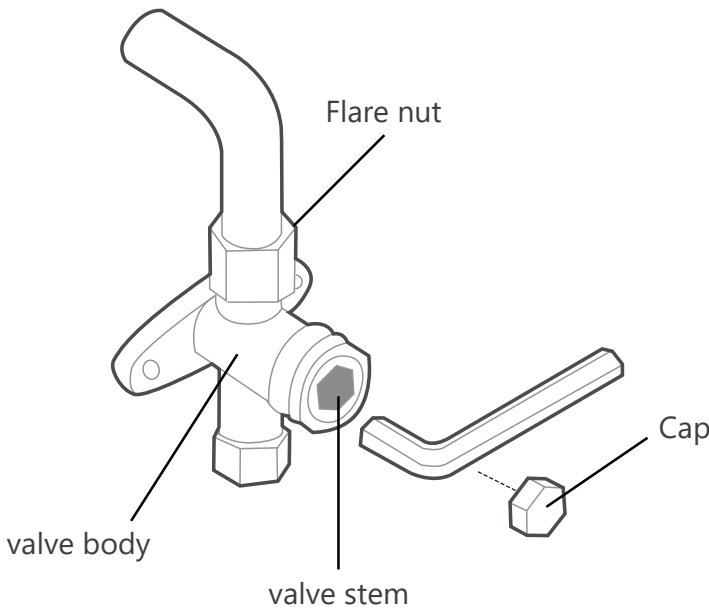


Fig. 9-2: Service Valve

- Using a hexagonal wrench, fully open both the high-pressure and low-pressure valves.
- Tighten all valve caps hand-tight plus one flat to ensure no leaks. You may tighten it further using a torque wrench if needed.

### NOTE ON ADDING REFRIGERANT

## ⚠ CAUTION

**DO NOT** mix refrigerant types.

Some systems require additional charging depending on pipe lengths. In North America, the standard pipe length is 25 ft. (7.5 m). The refrigerant should be charged from the service port on the outdoor unit's low-pressure valve. The additional refrigerant to be charged can be calculated using the following formula:

Table 9-1: Additional Refrigerant Formula

Refrigerant	Liquid Side Pipe Diameter		
	Ø1/4 in. (Ø6.35 mm)	Ø3/8 in. (Ø9.52mm)	Ø1/2 in. (Ø12.7 mm)
R454B	(Pipe length – standard length) x 0.16 oz/ft (Pipe length – standard length) x 15 g/m	(Pipe length – standard length) x 0.32 oz/ft (Pipe length – standard length) x 30 g/m	(Pipe length – standard length) x 0.69 oz/ft (Pipe length – standard length) x 65 g/m

makes any unusual noises.

- e. Check to see that the water is discharged. It may take up to one minute before the unit begins to drain depending on the drainpipe.
- f. Make sure that there are no leaks in any of the piping.
- g. Stop the air conditioner. Turn off the main power switch and reinstall the test cover.

#### NOTE

If the unit malfunctions or does not operate according to your expectations, please refer to the Troubleshooting section of the Owner's Manual before calling customer service.

## Trademarks Copyrights & Legal Statement

Midea logo, word marks, trade name, trade dress, and all versions thereof are valuable assets of Midea Group and/or its affiliates ("Midea"), to which Midea owns trademarks, copyrights, and other intellectual property rights, and all goodwill derived from using any part of a Midea trademark. Use of Midea trademark for commercial purposes without the prior written consent of Midea may constitute trademark infringement or unfair competition in violation of relevant laws.

This manual is created by Midea and Midea reserves all copyrights thereof. No entity or individual may use, duplicate, modify, distribute in whole or in part this manual, or bundle or sell with other products without the prior written consent of Midea.

All the functions and instructions described were up to date at the time of printing this manual. However, the actual product may vary due to improved functions and designs.

## Disposal & Recycling

This symbol indicates that this product shall not be disposed of with other household waste at the end of its service life. Used devices must be returned to an official collection point for recycling of electrical electronic devices. To find these collection systems please contact your local authorities or retailer where the product was purchased. Each household performs an important role in recovering and recycling old appliances. Appropriate disposal of used appliances helps prevent potential negative consequences for the environment and human health.



## Data Protection Notice

For the provision of the services agreed with the customer, we agree to comply without restriction with all stipulations of applicable data protection law, in line with agreed countries within which services to the customer will be delivered, as well as, where applicable.

Generally, our data processing is to fulfill our obligation under contract with you and for product safety reasons, to safeguard your rights in connection with warranty and product registration questions. In some cases, but only if appropriate data protection is ensured, personal data might be transferred to recipients located outside of the European Economic Area.

Further information is provided upon request. You can contact our Data Protection **MideaDPO@midea.com**. To exercise your rights such as the right to object to your personal data being processed for direct marketing purposes, please contact us via **MideaDPO@midea.com**. To find further information, please follow the QR Code.

## **North American HVAC Products Ltd.**

---

Add.: #100 5118 N Fraser Wy, Burnaby, BC V5J 0H1

Tel: 604-430-8496 [info@nahvac.com](mailto:info@nahvac.com) [www.nahvac.com](http://www.nahvac.com)

Midea reserves the right to change the specifications of the product, and to withdraw or replace products without prior notification or public announcement.  
Midea is constantly developing and improving its products.