



Midea MCPM Series A Coil



Contents:

- 1 NOMENCLATURE.....2
- 2 SPECIFICATIONS.....4
- 3 DIMENSIONS.....5
- 4 PISTON.....6
- 4 AIRFLOW PERFORMANCE.....7



Features:

- | | |
|---|--|
| <ul style="list-style-type: none"> • Multi-refrigerant:
Coils are designed compatible with R410A and R22 refrigerant. • High quality heat-exchanger:
Constructed of enhanced aluminum fins and internally grooved copper tubing. • Insulated cabinet:
Evaporator coil cabinets are thermally insulated with foil faced insulation to prevent sweating. (Cased coil only) | <ul style="list-style-type: none"> • Multi-position installation:
Cased coil has two drain pans, and can satisfy multi-position installation. (Cased coil only) • Widely match:
Cased & uncased a coils match Midea unitary products and many brand-name, popular gas furnaces and split system. • UL listed. |
|---|--|

1 Nomenclature

M	C	P	M	3	0	3	6	A	N	O	A
1	2	3	4		5		6	7	8	9	

Legend		
No.	Code	Remarks
1	M	Brand: Midea brand
2	C	Coil
3	P	?
4	M	Installation type: M: Multiple Position Installation V: Vertical Position Installation
5	3036	Capacity: 3036: 30/36KBtu/h Note: The coil is designed for 30K and 36K condenser unit.
6	A	Cabinet Size
7	N	Refrigerant type: R410A
8	0	Valve type: O: Orifice(Piston) T: TXV E: EEV(Reserved)
9	A	Version Number

2 Specifications

	MCPM3036ANO	MCPM3036BNO	MCPM3036CNO	MCPM3642BNO
INSTALLATION	Multiple position	Multiple position	Multiple position	Multiple position
SUPPLY DUCT(in.)	13	16	19-1/2	16
NOMINAL RATING Max. Cooling (BTU/h)	30,000/36,000	30,000/36,000	30,000/36,000	36,000/42,000
EVAPORATOR COIL Type Tube Material Tube Size(in.)	Tube & Fin Aluminum 9/32	Tube & Fin Aluminum 9/32	Tube & Fin Aluminum 9/32	Tube & Fin Aluminum 9/32
REFRIGERANT CONNECTION SIZE Liquid Line Size (O.D.) Suction Line Size (O.D.)	3/8 3/4	3/8 3/4	3/8 3/4	3/8 7/8

	MCPM3642CNO	MCPM3642DNO	MCPM4248BNO	MCPM4248CNO
INSTALLATION	Multiple position	Multiple position	Multiple position	Multiple position
SUPPLY DUCT(in.)	19-1/2	23	16	19-1/2
NOMINAL RATING Max. Cooling (BTU/h)	36,000/42,000	36,000/42,000	42,000/48,000	42,000/48,000
EVAPORATOR COIL Type Tube Material Tube Size(in.)	Tube & Fin Aluminum 9/32	Tube & Fin Aluminum 9/32	Tube & Fin Aluminum 9/32	Tube & Fin Aluminum 9/32
REFRIGERANT CONNECTION SIZE Liquid Line Size (O.D.) Suction Line Size (O.D.)	3/8 7/8	3/8 7/8	3/8 7/8	3/8 7/8

Specifications

	MCPM4248DNOH	MCPM4860CNOH	MCPM4860DNOH
INSTALLATION	Multiple position	Multiple position	Multiple position
SUPPLY DUCT(in.)	23	19-1/2	23
NOMINAL RATING Max. Cooling (BTU/h)	42,000/48,000	48,000/60,000	48,000/60,000
EVAPORATOR COIL Type Tube Material Tube Size(in.)	Tube & Fin Aluminum 9/32	Tube & Fin Aluminum 9/32	Tube & Fin Aluminum 9/32
REFRIGERANT CONNECTION SIZE Liquid Line Size (O.D.) Suction Line Size (O.D.)	3/8 7/8	3/8 7/8	3/8 7/8

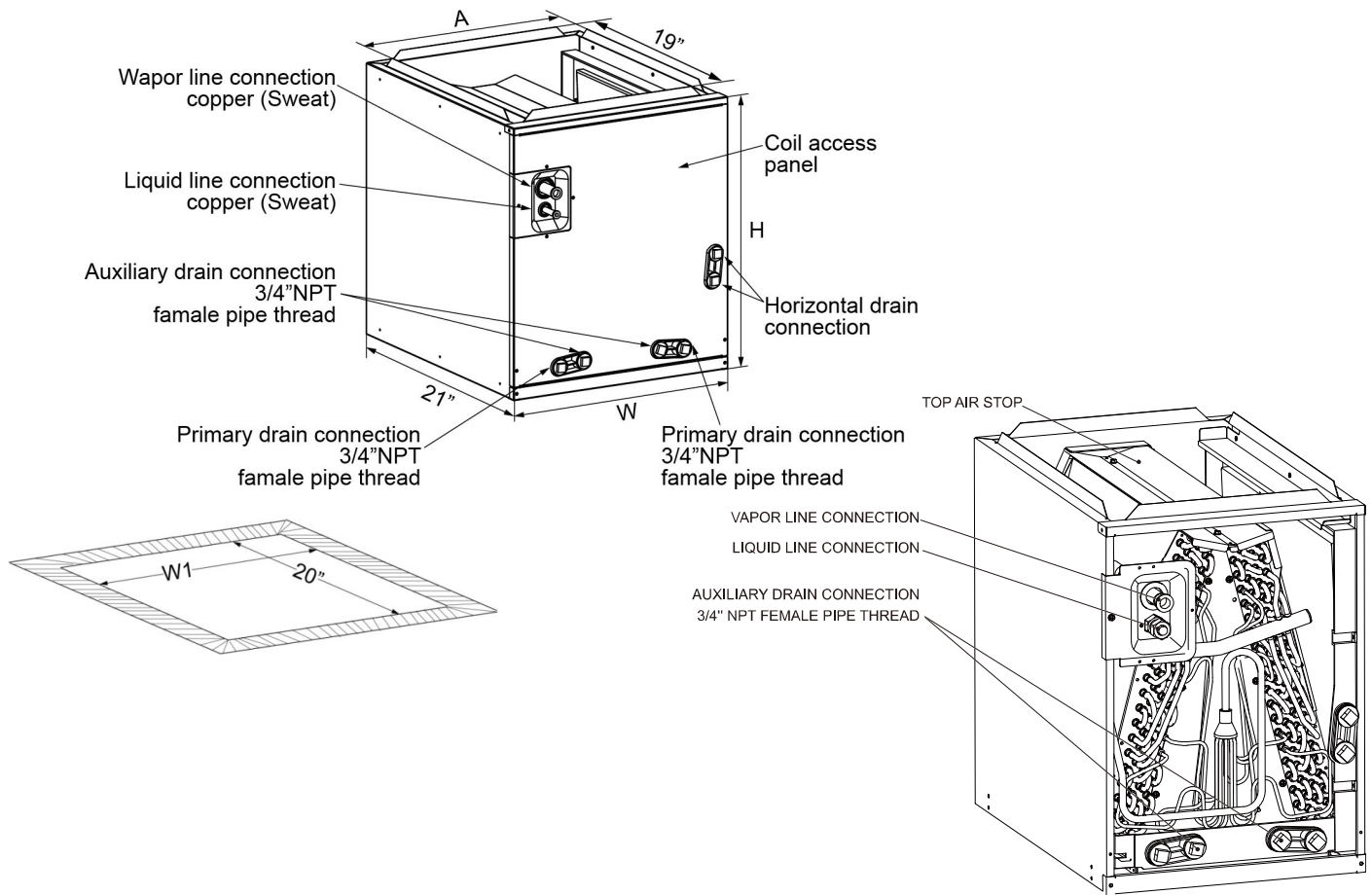
3 Dimensions

Model	Unit Dimensions					Weight (lbs.)
	Unit height "H" (in.)	Unit width "W" (in.)	Supply duct "A" (in.)	"W1" (in.)	Liquid line/ Vapor line	
MCPM3036ANO	20	14-1/2	13	13-1/2	3/8 / 3/4	46
MCPM3036BNO	20	17-1/2	16	16-1/2	3/8 / 3/4	49
MCPM3036CNO	20	21	19-1/2	20	3/8 / 3/4	51
MCPM3642BNO	26	17-1/2	16	16-1/2	3/8 / 7/8	60
MCPM3642CNO	26	21	19-1/2	20	3/8 / 7/8	62
MCPM3642DNO	26	24-1/2	23	23-1/2	3/8 / 7/8	66
MCPM4248BNO	30	17-1/2	16	16-1/2	3/8 / 7/8	73
MCPM4248CNO	30	21	19-1/2	20	3/8 / 7/8	73
MCPM4248DNO	30	24-1/2	23	23-1/2	3/8 / 7/8	77
MCPM4860CNO	30	21	19-1/2	20	3/8 / 7/8	82
MCPM4860DNO	30	24-1/2	23	23-1/2	3/8 / 7/8	86

4 Piston

Factory installed piston size for each coil model. Additional piston sizes are provided in the ship-with literature bag as necessary

Model	Piston/orifice sizes												
	50	52	56	58	60	64	68	70	73	75	80	83	90
MCPM3036ANO		X		X	X	X*		X					
MCPM3036BNO		X		X	X	X*		X					
MCPM3036CNO		X		X	X	X*		X					
MCPM3642BNO		X			X	X		X		X*			
MCPM3642CNO					X	X		X		X*			
MCPM3642DNO					X	X		X		X*			
MCPM4248BNO				X		X		X		X		X*	
MCPM4248CNO						X		X		X		X*	
MCPM4248DNO								X		X		X*	
MCPM4860CNO										X	X	X	X*
MCPM4860DNO										X	X	X	X*

Note: * means that this piston is pre-installed

Piston superheat charging chart

Outdoor temp(°F)	Indoor Temperature(°F) Dry Bulb/Wet Bulb					
	95/79	90/75	85/71	80/67	75/63	70/58
	Superheat					
115	23	16	7	5	5	5
110	24	17	9	5	5	5
105	26	19	11	5	5	5
100	27	21	13	7	5	5
95	29	23	16	9	5	5
90	30	25	18	12	5	5
85	35	26	20	14	8	5
80	34	28	22	17	11	5
75	35	30	24	19	13	6
70	37	32	26	21	16	10
65	38	34	29	24	19	13
60	40	36	31	27	22	17
55	41	37	33	29	25	21

Note: Chart is based on 400CFM/Ton indoor airflow and 50% relative humidity. If indoor relative humidity is above 70% or below 20%, use indoor wet bulb temperature only.

Airflow range is 375 to 425 CFM/Ton

5 Airflow Performance

Pressure drop characteristics for cooling and heat pump coils								
Pressure drop (Inches of water)								
Model	0.05	0.1	0.15	0.2	0.25	0.3	0.35	0.4*
MCPM3036ANO H	307	485	618	729	823	911	991	1063
MCPM3036BNO H	327	527	682	810	925	1024	1122	1217
MCPM3036CNO H	360	585	748	893	1019	1132	1238	1348
MCPM3642BNO H	401	600	773	916	1045	1160	1256	1357
MCPM3642CNO H	457	663	856	1019	1156	1277	1394	1502
MCPM3642DNO H	496	718	924	1102	1259	1398	1530	1651
MCPM4248BNO H	456	638	810	953	1077	1191	1284	1390
MCPM4248CNO H	505	726	932	1098	1244	1375	1494	1604
MCPM4248DNO H	533	857	1105	1319	1509	1675	1824	1956
MCPM4860CNO H	439	699	906	1071	1224	1362	1487	1589
MCPM4860DNO H	466	764	978	1157	1313	1466	1590	1695

Data based on wet coil with entering air at 80 degF DB / 67 degF WB without air filter. The maximum allowable pressure drop is 0.4 IWG.

The maximum CFM is the data at 0.4 IWG pressure.

Maximum airflow setting

Maximum airflow setting (CFM)				
Model	Up flow	Horizontal Left	Down flow	Horizontal Right
MCPM3036ANO H	1200	1050	1050	1200
MCPM3036BNO H	1250	1200	1050	1250
MCPM3036CNO H	1250	1200	1050	1250
MCPM3642BNO H	1575	1400	1400	1575
MCPM3642CNO H	1575	1400	1400	1575
MCPM3642DNO H	1575	1450	1450	1575
MCPM4248BNO H	1800	1800	1700	1500
MCPM4248CNO H	1800	1800	1700	1700
MCPM4248DNO H	1800	1800	1700	1700
MCPM4860CNO H	1850	1750	1750	1850
MCPM4860DNO H	2000	1850	1850	2000

Note: Water blow-off could occur in certain installation positions if the airflow setting exceeds the maximum values listed.