

SUBMITTAL DATA SHEET



Series Name: PWHP Bracket
 Model Number: PWHPKIT02

Console Heat Pump System

Location:	Approval:
Engineer:	Date:
Submitted to:	Construction:
Submitted by:	Unit #:
Reference:	Drawing #:



BRACKET SPECIFICATION

Package (W×D×H)	inch	710x710x315
	mm	28x28x12 3/8
Net/Gross Weight	lbs	18.3/30.9
	kg	8.3/14

Unit Dimension

Unit: inch (mm)

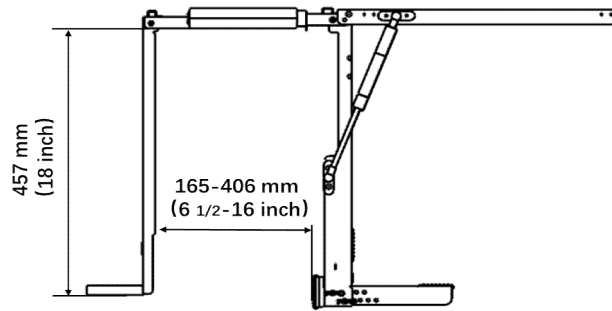

Installation Instruction

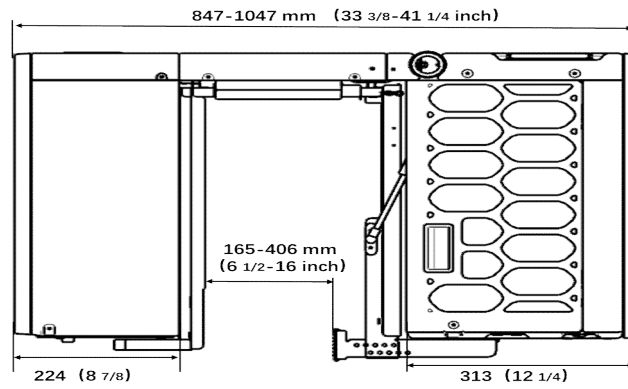

North American HVAC Products Ltd.

Add.: #100 5118 N Fraser Wy, Burnaby, BC V5J 0H1

Tel: 604-430-8496 info@nahvac.com www.nahvac.com

Midea reserves the right to change the specifications of the product, and to withdraw or replace products without prior notification or public announcement.
Midea is constantly developing and improving its products.