



# Midea EVOX Family of Inverter Heat Pumps

Easy Upgrade Solutions  
for Every Family



# Not Your Ordinary Heat Pump

## Midea EVOX Family of Inverter Heat Pumps



**Outdoor Inverter  
Condenser**



## EVOX Heat Pump for Flexible Heating Combinations

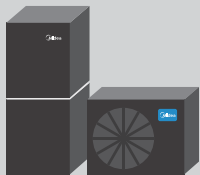

**ELECTRIC**

### Cold Climate Heat Pump

Midea EVOX Heat Pump  
100% heating output at -4°F



**ELECTRIC**

### Combo Heat

Midea EVOX Heat Pump+Auxiliary Heat Kit  
Activate the auxiliary heat strip to let the system rapidly reach the set temperature on extreme weather days

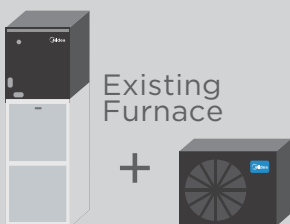

**ELECTRIC+GAS**

### Dual Fuel

Midea EVOX Heat Pump+A-coil

Pair the EVOX system with an existing furnace to let it determine the best source of heat (gas or electric) on cold days to guarantee peak efficiency and comfort of your HVAC system

# Why Choose a Midea **EVOX System?**

## Designed for Cold Climate Conditions

**100% Heating Capacity at 5°F** with COP up to 2.0

**Continuous Operation as Cold as -22°F**

### NOT THE ORDINARY **EFFICIENCY**

**EXheat** Side Discharge Technology

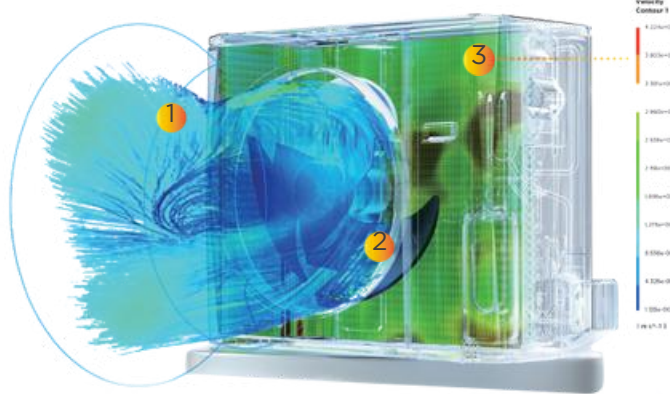

**1. Even Wind Field**  
Diffusing windshield to enlarge the air supply rate and reduce wind resistance



**2. Side-placed Wind Wheel**  
Allows optimal cross-ventilation between the wind field and thermal field



**3. Side-placed Wind Wheel and Vertical High Efficiency Heat Exchanger**  
The unit structure with side-placed wind wheel and vertical heat exchanger guarantee more uniform and efficient heat exchanging velocity across the entire heat exchanger surface. When temperature gets down, the system shows higher heat exchanging efficiency and provides stronger heating output..

### NOT THE ORDINARY **PERFORMANCE**

**M-POWERVI**  
Enhanced Vapor Injection Compressor



Powerful Discharge Capacity

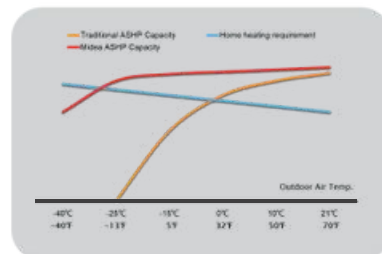

Enhanced Vapor Injection

### ELIGIBLE FOR MANY **REBATE PROGRAMS**

United States Up to **\$2,000**

Meeting CEE's Highest Tier, eligible for up to 52,000 25C tax credits

Canada Up to **\$5,000**

Eligible for the Canada Greener Homes Grant Program with a reimbursement of up to \$5,000 for retrofit

# Why Choose a Midea EVOX System?

## Save Money, Save Time

### BI-COMM TECHNOLOGY ALLOWS FOR COST-EFFECTIVE REPLACEMENT



#### 485 Communication Mode

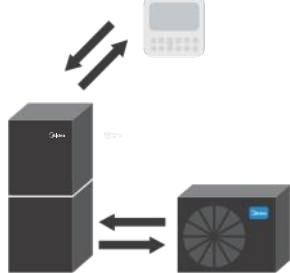

EVOX Heat pump  
EVOX Air Handler  
Midea Wired  
Controller

OR

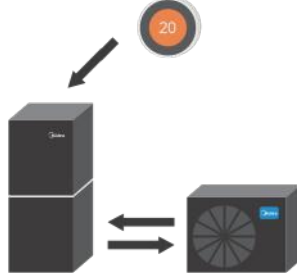

EVOX Heat Pump  
Air Handler  
24V Thermostat

#### 24V Self-Adapt Mode

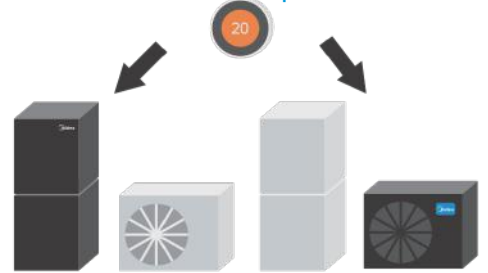

EVOX/Third-Party Heat  
Pump  
EVOX/Third-Party Air  
Handler  
Third-Party 24V  
Thermostat

### Premium Upgrade (485)

Future Upgrade

Over-the-air update  
technology (OTA)  
for future comfort  
enhancements

Wireless BACnet  
Capability

Integrates with new  
or existing Building  
Management Systems

### Flexible mix & match (24v)

Flexibly mix & match with most  
third-party indoor units, outdoor units,  
and thermostats, even without chang-  
ing wiring or refrigerant lines

# Why Choose a Midea **EVOK System?**

## Save Money, Save Time

### CONSTANT AIRFLOW TECHNOLOGY 2.0 ALLOWS FOR LESS INSTALLATION & SETUP TIME



Different Ductwork Designs, Same Air Volume

#### Normal Filter



Total Static Pressure **0.4"**  
Total Air Flow Volume **1200CFM**

#### MERV 13



Total Static Pressure **0.8"**  
Total Air Flow Volume **1200CFM**

Diverse Filtration Needs, Same Air Volume

## ALLOWS CUSTOMIZED AIR VOLUME FOR THE WHOLE HOME

**A**

Case 1:  
A house in a southern hot region like Las Vegas needs faster cooling

**B**

Case 2:  
A limited space needs smaller airflow

Case 3:  
Some homeowners prefer a quieter environment

#### CFM vs Total ESP

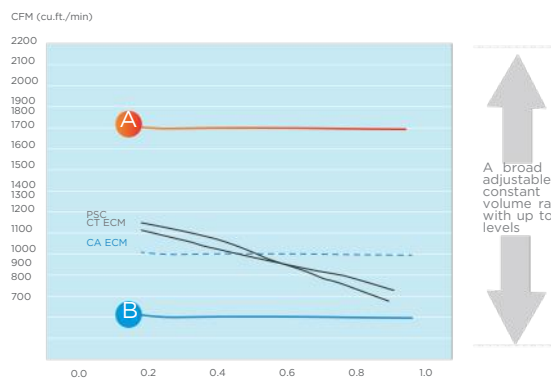

Total ESP (External Static Pressure)

#### Engineer Mode



# EVOX Family Outdoor Inverter Condenser

## IDEAL FOR DIFFERENT CLIMATES

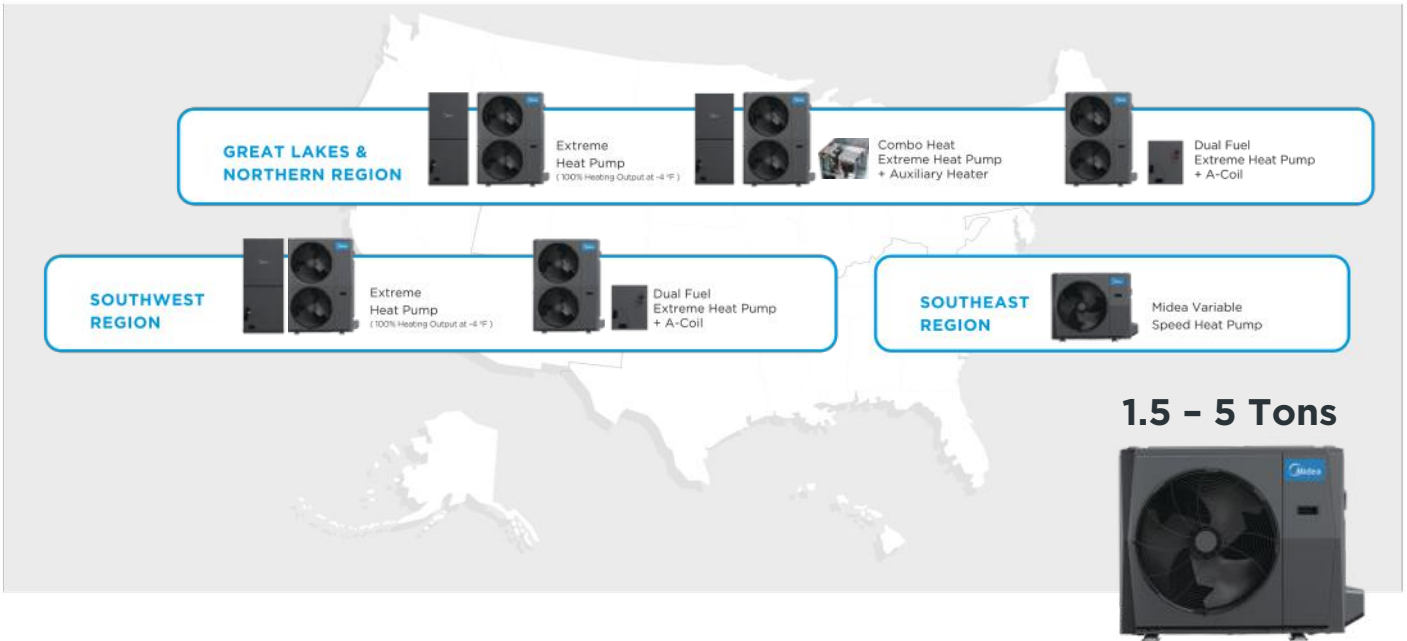

## EASY TO FIT IN ANY SPACE

Thinner design and lighter weight provides unmatched flexibility to fit in any unique home space.

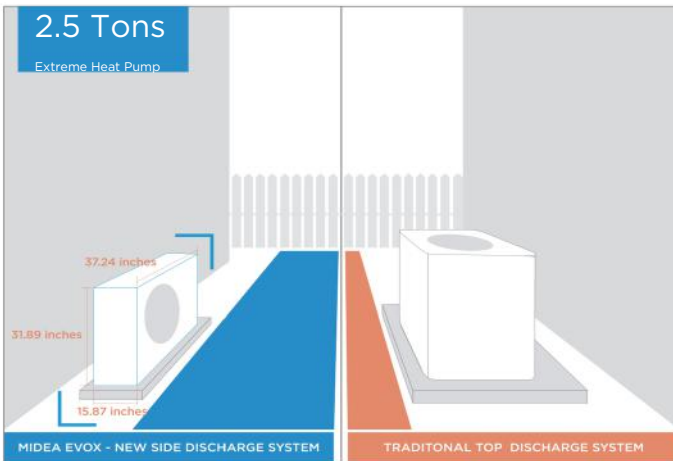

>> Fit more in your tech van or truck, with up to 4-5 EVOX units as opposed to 1-2 traditional units  
>> Easy to bring to the installation site and install on pad; single fan unit can be transported by just a single worker

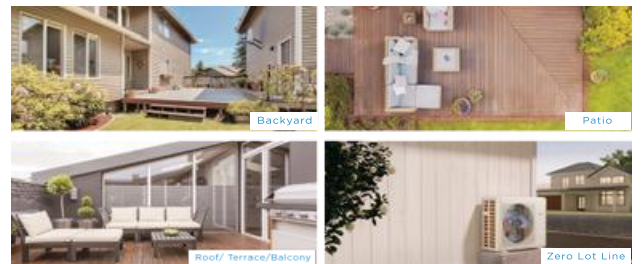

## ADVANCED COMPONENTS



New Generation Integrated Electronic Control



Small Tube Diameter Heat Exchanger with High Density Teeth



Low-vortex high-efficiency Silent fan blade



Compressor with New Slot Design



# What Makes **EVOX Easy?**



**OTA Upgrade**  
Remote system  
upgrades for latest  
software updates



**Icheck**  
Automatic diagnosis  
of the system issues



**Demand Response**  
Public Electricity  
Loading Management



**Enlarged Operation  
Space & Added  
Diagnostic Board for  
ODUs**



**Separate 24V &  
s1/s2 terminals**



**A2L Disperse System**



**Multi-Voltage**



**Slimmer Outdoor  
Units**

## Perfect for North American Homes

Inverter Heat Pump & Standard Air Handler System



### CORE FEATURES OF STANDARD AIR HANDLER

SEER2 Up to  
**19**

EER2 Up to  
**12.5**

HSPF4 Up to  
**10.2**



**1.5-5 Tons**

**A** 1.5-2 tons:  
21" x 17-1/2" x 45"

**B** 2.5-3 tons:  
21" x 21" x 49"

**C** 4-5 tons:  
21" x 24-1/2" x 53"

### FITS DIFFERENT INSTALLATION SPACES

4-Way Installation (Left/Right/Up/Down)



## ADVANCED COMPONENTS



1. Compatible with 485 or 24V: automatically identifying the control mode, no need for manual conversion.
2. Constant CFM ECM motor provides consistent airflow up to 0.8 in. w.c.
3. Electronic expansion valve (EEV) control: better throttling for highly efficient operation.
4. Optional auxiliary heat kits available up to 25kW.
5. All-Aluminum Coil.
6. Quiet Operation - down to 35 dB(A) level.

## EASY TO SERVICE



### Streamlined Troubleshooting

Easily accessible error code display

### Easy Access

Remove two screws for access to the electrical board, blower, heater

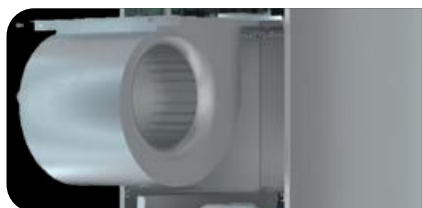

### Slide-Out Fan

Easily remove the fan motor for straightforward maintenance

### Magnetic Filter Cover

One click for filter access



# EVOX Air Handler Extreme Heat\_Specification Up to 19 SEER2

MODEL	INDOOR UNIT		MAUHE H188-2A	MAUHE H248-2A	MAUHE H308-2A	MAUHE H368-2A	MAUHE H488-2A	MAUHE H608-2A
	OUTDOOR UNIT		MO18E H188-2A	MO18E H248-2A	MO18E H308-2A	MO18E H368-2A	MO18E H488-2A	MO18E H608-2A
<b>PERFORMANCE</b>								
<b>POWER SUPPLY</b>	IDU	V, Ph, Hz	115/208/230, 1, 60	115/208/230, 1, 60	115/208/230, 1, 60	115/208/230, 1, 60	115/208/230, 1, 60	115/208/230, 1, 60
	ODU	V, Ph, Hz	208/230, 1, 60	208/230, 1, 60	208/230, 1, 60	208/230, 1, 60	208/230, 1, 60	208/230, 1, 60
<b>SEER2 (AHRI 218/248-2023)</b>	Cooling Capacity	Btu/h	18,000	23,000	30,000	36,000	48,000	54,000
	Heating Capacity	Btu/h	19,000	24,000	34,000	37,000	50,000	56,000
	SEER2	Btu/W	19	18.3	16.8	17.4	16.5	16
	EER2	Btu/W	12.5	11.7	11.7	11.7	10.5	10
	HSPF4	Btu/W	9.7	10	10	10.2	9.5	9
<b>HEATING @ 5 (-15°C) °F</b>	Rated capacity	Btu/h	18,000	21,600	32,600	39,000	46,000	52,000
	COP	W/W	2	1.87	1.96	1.9	1.9	1.8
<b>INDOOR UNIT</b>								
<b>AIR FLOW VOLUME</b>	Turbo/Hi/Mi/Lo/Si	CFM	618/577/530/489/489	824/759/695/630/630	989/895/806/712/712	1189/1083/971/865/865	1601/1472/1283/1095/1095	1807/1583/1360/1136/1136
<b>NOISE LEVEL</b>	Turbo/Hi/Mi/Lo/Si	dB(A)	41/41/39/33/33	44/44/42/28/28	47/46/43/27/27	49/48/46/26/26	52/52/50/34/34	55/52/50/35/35
<b>Net DIMENSION</b>	WxDxH	mm	534×445×1143	534×445×1143	534×534×1245	534×534×1245	534×622×1346	534×622×1346
	WxDxH	inch	21×17-1/2×45	21×17-1/2×45	21×21×49	21×21×49	21×24-1/2×53	21×24-1/2×53
<b>PACKING DIMENSION</b>	WxDxH	mm	675×530×1235	675×530×1235	675×620×1335	675×620×1335	710×680×1435	710×680×1435
	WxDxH	inch	26-5/8×20-7/8×48-5/8	26-5/8×20-7/8×48-5/8	26-5/8×24-3/8×52-1/2	26-5/8×24-3/8×52-1/2	28×26-3/4×56-1/2	28×26-3/4×56-1/2
<b>Net/GROSS WEIGHT</b>		kg	48/58.7	47.9/57.8	58.6/70.6	58.6/70.6	58.6/70.6	59.2/70.9
		lbs	106/129	106/127	129/156	129/156	129/156	131/156

# EVOX Air Handler Regular Heat\_Specification Up to 18.8 SEER2



MODEL	INDOOR UNIT		MAUHE H188-2A	MAUHE H248-2A	MAUHE H308-2A	MAUHE H368-2A	MAUHE H488-2A	MAUHE H608-2A
	OUTDOOR UNIT		MO18E H188-2A	MO18E H248-2A	MO18E H308-2A	MO18E H368-2A	MO18E H488-2A	MO18E H608-2A
<b>PERFORMANCE</b>								
<b>POWER SUPPLY</b>	IDU	V, Ph, Hz	115/208/230, 1, 60	115/208/230, 1, 60	115/208/230, 1, 60	115/208/230, 1, 60	115/208/230, 1, 60	115/208/230, 1, 60
	ODU	V, Ph, Hz	208/230, 1, 60	208/230, 1, 60	208/230, 1, 60	208/230, 1, 60	208/230, 1, 60	208/230, 1, 60
<b>SEER2 (AHRI 218/248-2023)</b>	Cooling Capacity	Btu/h	18,000	24,000	30,000	36,000	48,000	54,000
	Heating Capacity	Btu/h	18,000	26,000	31,000	36,000	48,000	54,000
	SEER2	Btu/W	18.8	18.1	17.0	16.1	16.0	15.2
	EER2	Btu/W	11.0	11.0	10.7	10.0	10.0	8.6
	HSPF4	Btu/W	9	10	9	9	9	8
<b>HEATING @ 5 (-15°C) °F</b>	Rated capacity	Btu/h	11,200	21,600	19,100	27,000	38,000	38,000
	COP	W/W	2.0	1.9	2.0	2.0	1.9	1.8
<b>INDOOR UNIT</b>								
<b>AIR FLOW VOLUME</b>	Turbo/Hi/Mi/Lo/Si	CFM	618/577/530/489/489	824/759/695/630/630	989/895/806/712/712	1189/1083/971/865/865	1601/1472/1283/1095/1095	1807/1583/1360/1136/1136
<b>NOISE LEVEL</b>	Turbo/Hi/Mi/Lo/Si	dB(A)	44/43/41/33/33	44/44/42/28/28	46/46/42/29/29	48/48/45/28/28	53/53/50/44/44	56/52/49/35/35
<b>Net DIMENSION</b>	WxDxH	mm	534×445×1143	534×445×1143	534×534×1245	534×534×1245	534×622×1346	534×622×1346
	WxDxH	inch	21×17-1/2×45	21×17-1/2×45	21×21×49	21×21×49	21×24-1/2 × 53	21×24-1/2 × 53
<b>PACKING DIMENSION</b>	WxDxH	mm	675×530×1235	675×530×1235	675×620×1335	675×620×1335	710×680×1435	710×680×1435
	WxDxH	inch	26-5/8×20-7/8×48-5/8	26-5/8×20-7/8×48-5/8	26-5/8×24-3/8×52-1/2	26-5/8×24-3/8×52-1/2	28×26-3/4×56-1/2	28×26-3/4×56-1/2
<b>Net/GROSS WEIGHT</b>		kg	48/57.5	47.9/57.8	58.5/69.6	58.7/69.8	73.9/86.6	73.9/86.6
		lbs	106/127	106/127	129/153	129/154	163/ 191	163/ 191

# Family Core Features



**Compatible with the Existing Gas Furnace**  
Inverter Heat Pump & A-Coil System

## UPGRADE YOUR HEATING AND COOLING FOR PEAK EFFICIENCY & COMFORT

During Winter: **Dual-Fuel Capability**





**Cold**  
Experience comfort and efficiency of heat pump.



**Freezing**  
When the temperature drops below  $-22^{\circ}\text{F}$ , use the gas furnace as an available backup.

During Summer: **Efficient Cooling**



**Hot**  
Experience ultimate comfort with highly efficient and powerful cooling capabilities.

## CORE FEATURES OF A-COIL



SEER2 Up to  
16.5

EER2 Up to  
11.7

### 1.5-5 Tons

#### The Most Comprehensive Size Options

- A** 1.5-2 tons: 14-1/2"×21"×18" 2.5-3 tons: 14-1/2"×21"×23-1/2"
- B** 1.5-2 tons: 17-1/2"×21"×18" 2.5-3 tons: 17-1/2"×21"×23-1/2"
- C** 2.5-3 tons: 21"×21"×23-1/2" 4-5 tons: 21"×21"×27-1/2"
- D** 4-5 tons: 24-1/2"×21"×28"

## VERSATILE APPLICATIONS

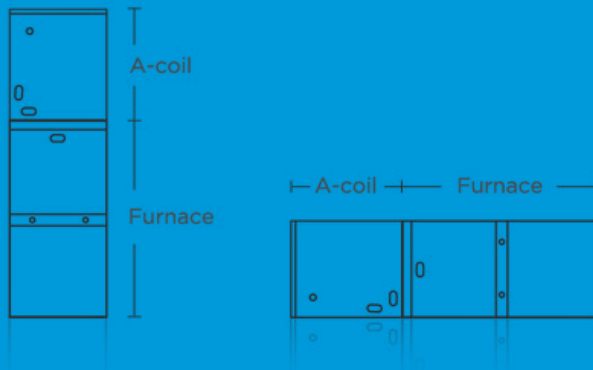

The **Flexible**  
Multipoise Design



**Uncased**  
& **CASED**

# A-COIL Extreme Heat\_Specification

MODEL	INDOOR UNIT		MAAHE-H24B-AA	MAAHE-H24B-BA	MAAHE-H24B-CA	MAAHE-H24B-DA	MAAHE-H36B-AA	MAAHE-H36B-BA	MAAHE-H36B-CA
	OUTDOOR UNIT		MOLHE-H18B-2A	MOLHE-H18B-2A	MOLHE-H24B-2A	MOLHE-H24B-2A	MOLHE-H36B-2A	MOLHE-H36B-2A	MOLHE-H36B-2A
<b>PERFORMANCE</b>									
<b>POWER SUPPLY</b>	V, Ph, Hz		208/230, 1, 60	208/230, 1, 60	208/230, 1, 60	208/230, 1, 60	208/230, 1, 60	208/230, 1, 60	208/230, 1, 60
<b>SEER2 (AHRI 210/240 - 2023)</b>	Cooling Capacity	Btu/h	18,000	18,000	24,000	24,000	30,000	30,000	30,000
	Heating Capacity	Btu/h	19,000	19,000	25,000	25,000	30,000	30,000	30,000
	SEER2	Btu/W	16.0	16.0	16.5	16.5	14.3	15.2	15.2
	EER2	Btu/W	11.7	11.7	10	10	8.5	10	10
	HSPF4	Btu/W	8.5	8.5	8.5	8.5	7.5	8.5	8.5
<b>HEATING @ 5 (-1.5°C) °F</b>	Rated capacity	Btu/h	15,000	20,000	20,000	20,000	25,000	27,000	27,000
	COP	W/W	1.8	1.8	1.8	1.8	1.75	1.8	1.8
<b>INDOOR UNIT</b>									
<b>Net DIMENSION</b>	WxDxH	mm	368× 534×457	445× 534×457	368× 534×457	445× 534×457	368× 534×599	445× 534×599	534×534×609
	WxDxH	inch	14-1/2×21× 18	17-1/2×21× 18	14-1/2×21× 18	17-1/2×21× 18	14-1/2×21× 23-1/2	17-1/2×21× 23-1/2	21×21× 23-1/2
<b>PACKING DIMENSION</b>	WxDxH	mm	450×665 × 525	520×665 × 515	450×665 × 525	520×665 × 515	450×665×660	520×665×645	610×665×670
	WxDxH	inch	17-3/4×26-1/8 ×20-5/8	17-5/8×26-1/8 ×20-1/4	17-3/4×26-1/8 ×20-5/8	17-5/8×26-1/8 ×20-1/4	17-3/4×26-1/8 ×26-1/8	17-5/8×26-1/8 ×25-3/8	20×26-1/8 ×26-3/8
<b>Net/GROSS WEIGHT</b>		kg	19.4/23.6	18.9/21.1	18.9/21.1	19.4/23.6	30.2/35	27.3/31.3	27.3/31.3
		lbs	43/52	42/47	42/47	43/52	67/77	60/69	60/69

MODEL	INDOOR UNIT		MAAHE-H36B-AA	MAAHE-H36B-BA	MAAHE-H36B-CA	MAAHE-H36B-DA	MAAHE-H48B-AA	MAAHE-H48B-BA	MAAHE-H48B-CA
	OUTDOOR UNIT		MOLSE-H36B-2A	MOLSE-H36B-2A	MOLSE-H36B-2A	MOLHE-H48B-2A	MOLHE-H48B-2A	MOLHE-H36B-2A	MOLHE-H36B-2A
<b>PERFORMANCE</b>									
<b>POWER SUPPLY</b>	V, Ph, Hz		208/230, 1, 60	208/230, 1, 60	208/230, 1, 60	208/230, 1, 60	208/230, 1, 60	208/230, 1, 60	208/230, 1, 60
<b>SEER2 (AHRI 210/240 - 2023)</b>	Cooling Capacity	Btu/h	32,000	36,000	36,000	45,000	45,000	52,000	54,000
	Heating Capacity	Btu/h	33,000	38,000	38,000	48,000	48,000	55,000	54,000
	SEER2	Btu/W	14.3	15.2	15.2	15.2	14.3	15.2	14.3
	EER2	Btu/W	8.5	10	10	10	8.6	10	8.6
	HSPF4	Btu/W	7.5	8.5	8.5	8.5	7.5	8.5	7.5
<b>HEATING @ 5 (-1.5°C) °F</b>	Rated capacity	Btu/h	27,000	36,000	36,000	42,000	42,000	45,000	42,000
	COP	W/W	1.8	1.8	1.8	1.8	1.8	1.8	1.8
<b>INDOOR UNIT</b>									
<b>Net DIMENSION</b>	WxDxH	mm	368× 534×599	445× 534×599	534×534×609	533× 534×709	622× 534×711	533× 534×709	622× 534×711
	WxDxH	inch	14-1/2×21× 23-1/2	17-1/2×21× 23-1/2	21×21× 23-1/2	21×21× 27-1/2	24-1/2×21× 28	21×21× 27-1/2	24-1/2×21× 28
<b>PACKING DIMENSION</b>	WxDxH	mm	450×665×660	520×665×645	610×665×670	610×665 × 775	705×665 × 770	610×665 × 775	705×665 × 770
	WxDxH	inch	17-3/4×26-1/8 ×26-1/8	17-5/8×26-1/8 ×25-3/8	20×26-1/8 ×26-3/8	24×26×30-1/2	27-3/4×26-1/8 ×30-1/4	24×26×30-1/2	27-3/4×26-1/8 ×30-1/4
<b>Net/GROSS WEIGHT</b>		kg	30.2/35	27.3/31.3	27.3/31.3	30.2/35	39.3/44.6	30.2/35	39.3/44.6
		lbs	67/77	60/69	60/69	67/77	87/98	67/77	87/98

# A-COIL Regular Heat\_Specification

MODEL	INDOOR UNIT		MAAHE H24B-AA	MAAHE H24B-BA	MAAHE H24B-CA	MAAHE H24B-DA	MAAHE H36B-AA	MAAHE H36B-BA	MAAHE H36B-CA
	OUTDOOR UNIT		MO1BE H18B-2A	MO1BE H18B-2A	MO1BE H24B-2A	MO1BE H24B-2A	MO1BE H36B-2A	MO1BE H36B-2A	MO1BE H36B-2A
<b>PERFORMANCE</b>									
<b>POWER SUPPLY</b>	V, Ph, Hz		208/230, 1, 60	208/230, 1, 60	208/230, 1, 60	208/230, 1, 60	208/230, 1, 60	208/230, 1, 60	208/230, 1, 60
<b>SEER2 (AHRI 210/240-2023)</b>	Cooling Capacity	Btu/h	18,000	18,000	24,000	24,000	28,000	30,000	30,000
	Heating Capacity	Btu/h	18,000	18,000	25,000	25,000	28,000	30,000	30,000
	SEER2	Btu/W	16	16	16	16	14.3	14.3	14.3
	EER2	Btu/W	10	10	10	10	8.5	8.5	8.5
	HSPF4	Btu/W	8.5	8.5	8.5	8.5	7.5	7.5	7.5
<b>HEATING @ 5 (-1.5 C) °F</b>	Rated capacity	Btu/h	11,000	11,000	20,000	20,000	15,000	17,000	17,000
	COP	W/W	1.8	1.8	1.8	1.8	1.7	1.8	1.8
<b>INDOOR UNIT</b>									
<b>Net DIMENSION</b>	WxDxH	mm	368× 534×457	445× 534×457	368× 534×457	445× 534×457	368× 534×599	445× 534×599	534×534×609
	WxDxH	inch	14-1/2×21× 18	17-1/2×21× 18	14-1/2×21× 18	17-1/2×21× 18	14-1/2×21× 23-1/2	17-1/2×21× 23-1/2	21×21× 23-1/2
<b>PACKING DIMENSION</b>	WxDxH	mm	450×665 × 525	520×665 × 515	450×665 × 525	520×665 × 515	450×665×660	520×665×645	610×665×670
	WxDxH	inch	17-3/4×26-1/8 ×20-5/8	17-5/8×26-1/8 ×20-1/4	17-3/4×26-1/8 ×20-5/8	17-5/8×26-1/8 ×20-1/4	17-3/4×26-1/8 ×26-1/8	17-5/8×26-1/8 ×25-3/8	20×26-1/8 ×26-3/8
<b>Net/GROSS WEIGHT</b>		kg	19.4/23.6	18.9/21.1	18.9/21.1	19.4/23.6	30.2/35	27.3/31.3	27.3/31.3
		lbs	43/52	42/47	42/47	43/52	67/77	60/69	60/69

MODEL	INDOOR UNIT		MAAHE H36B-AA	MAAHE H36B-BA	MAAHE H36B-CA	MAAHE H36B-DA	MAAHE H36B-DA	MAAHE H36B-DA	MAAHE H36B-DA
	OUTDOOR UNIT		MO1BE H36B-2A	MO1BE H36B-2A	MO1BE H36B-2A	MO1BE H48B-2A	MO1BE H48B-2A	MO1BE H36B-2A	MO1BE H36B-2A
<b>PERFORMANCE</b>									
<b>POWER SUPPLY</b>	V, Ph, Hz		208/230, 1, 60	208/230, 1, 60	208/230, 1, 60	208/230, 1, 60	208/230, 1, 60	208/230, 1, 60	208/230, 1, 60
<b>SEER2 (AHRI 210/240-2023)</b>	Cooling Capacity	Btu/h	32,000	35,000	35,000	45,000	45,000	50,000	49,000
	Heating Capacity	Btu/h	32,000	36,000	36,000	45,000	45,000	50,000	49,000
	SEER2	Btu/W	14.3	14.3	14.3	14.5	14.3	14.3	14.3
	EER2	Btu/W	8.5	8	8	8	8	8.5	8.5
	HSPF4	Btu/W	7.5	7.5	7.5	7.5	7.5	7.5	7.5
<b>HEATING @ 5 (-1.5 C) °F</b>	Rated capacity	Btu/h	22,000	25,000	25,000	32,000	30,000	34,000	34,000
	COP	W/W	1.65	1.75	1.75	1.75	1.75	1.75	1.75
<b>INDOOR UNIT</b>									
<b>Net DIMENSION</b>	WxDxH	mm	368× 534×599	445× 534×599	534×534×609	533× 534×709	622× 534×711	533× 534×709	622× 534×711
	WxDxH	inch	14-1/2×21× 23-1/2	17-1/2×21× 23-1/2	21×21× 23-1/2	21×21× 27-1/2	24-1/2×21× 28	21×21× 27-1/2	24-1/2×21× 28
<b>PACKING DIMENSION</b>	WxDxH	mm	450×665×660	520×665×645	610×665×670	610×665 × 775	705×665 × 770	610×665 × 775	705×665 × 770
	WxDxH	inch	17-3/4×26-1/8 ×26-1/8	17-5/8×26-1/8 ×25-3/8	20×26-1/8 ×26-3/8	24×26×30-1/2	27-3/4×26-1/8 ×30-1/4	24×26×30-1/2	27-3/4×26-1/8 ×30-1/4
<b>Net/GROSS WEIGHT</b>		kg	30.2/35	27.3/31.3	27.3/31.3	30.2/35	39.3/44.6	30.2/35	39.3/44.6
		lbs	67/77	60/69	60/69	67/77	87/98	67/77	87/98

# Ideal for Multi-family Homes

Inverter heat Pump & Ceiling/Wall Mounted Air Handler System



## CORE FEATURES OF WALL & CEILING MOUNTED AIR HANDLERS

SEER2 Up to  
**19.3**

EER2 Up to  
**12.1**

HSPF4 Up to  
**10.8**



**1.5-3 Tons**

**A** 1.5-2tons: 20-1/4" x 15-3/4" x 36-1/2"    **B** 2.5-3 tons: 22"x19"x 40"

SEER2 Up to  
**18.0**

EER2 Up to  
**12.0**

HSPF4 Up to  
**10.0**



**1.5-3 Tons**

**A** 1.5 tons: 43-1/2" x 23-3/8" x 10-7/8"    **B** 2 tons: 49-1/8" x 23-3/8" x 10-7/8"  
**C** 2.5 tons: 55-1/4" x 23-3/8" x 10-7/8"    **D** 3 tons: 62-1/8" x 23-3/8" x 10-7/8"



# ADVANCED COMPONENTS

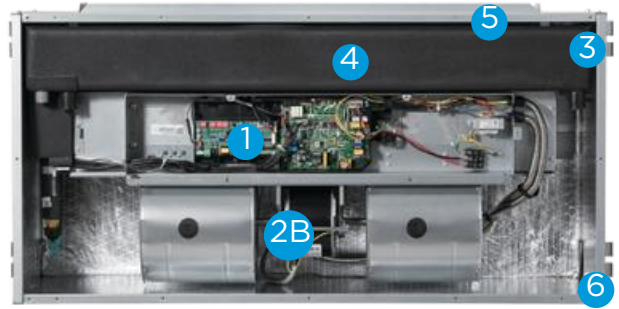

- 1** Compatible with 485 or 24V: automatically identifying the control mode, no need for manual conversion.

**2** A: Constant CFM ECM motor provides consistent airflow up to 0.8 in. w.c. B: Constant torque ECM motor provides sufficient airflow of up to 0.8 in. w.c.;

**3** Electronic expansion valve (EEV) control: better throttling for more highly efficient operation.
- 4** Optional auxiliary heat kits available up to 10kw

**5** All-Aluminum Coil

**6** Quiet Operation - inverter system runs at significantly lower dB(A) level

## EASY TO SERVICE

### Wall-Mounted Air Handler

**Easy-to-Access Design**  
Simply remove two screws for access to the error code display

**Easy-to-Maintain Design**  
Easily take out the electrical board & fan motor without the need to disassemble the evaporate

**Full Front Access**  
No screws on the side

**Slide-Track Design**  
Easily remove the evaporate coil through the slide track from the front side

**Slide-Out Design**  
A single action to insert or remove the filter

### Ceiling-Mounted Air Handler

Conveniently access the electrical board from the bottom of the unit

Easily remove the fan & motor as well as the electrical board & heater assembly

Simply remove two screws to access the error code display

Additional lock holds PCB cover in place

# Wall mounted AHU Extreme Heat\_Specification Up to 19.3 SEER2

MODEL	INDOOR UNIT		MAWHE-H18B-2A	MAWHE-H24B-2A	MAWHE-H36B-2A	MAWHE-H66B-2A
	OUTDOOR UNIT		MO1HE-H18B-2A	MO1HE-H24B-2A	MO1HE-H36B-2A	MO1SE-H66B-2A
<b>PERFORMANCE</b>						
<b>POWER SUPPLY</b>	IDU	V, Ph, Hz	115/208/230, 1, 60	115/208/230, 1, 60	115/208/230, 1, 60	115/208/230, 1, 60
	ODU	V, Ph, Hz	208/230, 1, 60	208/230, 1, 60	208/230, 1, 60	208/230, 1, 60
<b>SEER2 (AHRI 218/248-2023)</b>	Cooling Capacity	Btu/h	18,000	22,000	30,000	36,000
	Heating Capacity	Btu/h	19,000	24,000	31,000	37,000
	SEER2	Btu/W	19.3	17.5	17.5	16.8
	EER2	Btu/W	12.1	11.7	11.7	11.2
	HSPF4	Btu/W	10.8	10.5	10.2	9.6
<b>HEATING @ 5 (-15°C) °F</b>	Rated capacity	Btu/h	18,000	19,000	29,000	36,000
	COP	W/W	2.1	1.96	2.00	1.8
<b>INDOOR UNIT</b>						
<b>AIR FLOW VOLUME</b>	Turbo/Hi/Mi/Lo/Si	CFM	618/577/530/489/489	824/759/695/630/630	989/895/806/712/712	1189/1083/971/865/865
<b>NOISE LEVEL</b>	Turbo/Hi/Mi/Lo/Si	dB(A)	48/47/45/39/39	53/51/48/38/38	51/50/48/36/36	51/51/48/37 /37
<b>Net DIMENSION</b>	WxDxH	mm	515×399×928	515×399×928	559×483×1017	559×483×1017
	WxDxH	inch	20-1/4×15-3/4×36-1/2	20-1/4×15-3/4×36-1/2	22×19×40	22×19×40
<b>PACKING DIMENSION</b>	WxDxH	mm	580×495×1090	580×495×1090	625×580×1193	625×580×1193
	WxDxH	inch	22-7/8×19-1/2×42-7/8	22-7/8×19-1/2×42-7/8	24-5/8×22-7/8×47	24-5/8×22-7/8×47
<b>Net/GROSS WEIGHT</b>		kg	40/49.5	40/49.5	49.4/60.3	49.4/60.3
		lbs	88/109	88/109	109/133	109/133

# Wall mounted AHU Regular Heat\_Specification Up to 18 SEER2

MODEL	INDOOR UNIT		MAWHE-H18B-2A	MAWHE-H24B-2A	MAWHE-H36B-2A	MAWHE-H66B-2A
	OUTDOOR UNIT		MO1SE-H18B-2A	MO1SE-H24B-2A	MO1SE-H36B-2A	MO1SE-H66B-2A
<b>PERFORMANCE</b>						
<b>POWER SUPPLY</b>	IDU	V, Ph, Hz	115/208/230, 1, 60	115/208/230, 1, 60	115/208/230, 1, 60	115/208/230, 1, 60
	ODU	V, Ph, Hz	208/230, 1, 60	208/230, 1, 60	208/230, 1, 60	208/230, 1, 60
<b>SEER2 (AHRI 218/248-2023)</b>	Cooling Capacity	Btu/h	18,000	24,000	30,000	36,000
	Heating Capacity	Btu/h	18,000	25,000	31,000	37,000
	SEER2	Btu/W	18.5	17.4	18.6	16.7
	EER2	Btu/W	11.5	10.8	11	10.2
	HSPF4	Btu/W	9.4	10.4	8.7	9.3
<b>HEATING @ 5 (-15°C) °F</b>	Rated capacity	Btu/h	11,400	19,400	18,700	29,200
	COP	W/W	2.1	1.96	1.99	1.99
<b>INDOOR UNIT</b>						
<b>AIR FLOW VOLUME</b>	Turbo/Hi/Mi/Lo/Si	CFM	618/577/530/489/489	824/759/695/630/630	989/895/806/712/712	1189/1083/971/865/865
<b>NOISE LEVEL</b>	Turbo/Hi/Mi/Lo/Si	dB(A)	48/47/45/39/39	53/51/48/38/38	51/50/48/36/36	51/51/48/37 /37
<b>Net DIMENSION</b>	WxDxH	mm	515×399×928	515×399×928	559×483×1017	559×483×1017
	WxDxH	inch	20-1/4×15-3/4×36-1/2	20-1/4×15-3/4×36-1/2	22×19×40	22×19×40
<b>PACKING DIMENSION</b>	WxDxH	mm	580×495×1090	580×495×1090	625×580×1193	625×580×1193
	WxDxH	inch	22-7/8×19-1/2×42-7/8	22-7/8×19-1/2×42-7/8	24-5/8×22-7/8×47	24-5/8×22-7/8×47
<b>Net/GROSS WEIGHT</b>		kg	40/49.5	40/49.5	49.4/60.3	49.4/60.3
		lbs	88/109	88/109	109/133	109/133

# Pancake Extreme Heat\_Specification Up to 19 SEER2

MODEL	INDOOR UNIT		MAPHE-H188-2A	MAPHE-H248-2A	MAPHE-H368-2A	MAPHE-H368-2A
	OUTDOOR UNIT		MO1HE-H188-2A	MO1HE-H248-2A	MO1HE-H368-2A	MO1SE-H368-2A
<b>PERFORMANCE</b>						
<b>POWER SUPPLY</b>	IDU	V, Ph, Hz	115/208/230, 1, 60	115/208/230, 1, 60	115/208/230, 1, 60	115/208/230, 1, 60
	ODU	V, Ph, Hz	208/230, 1, 60	208/230, 1, 60	208/230, 1, 60	208/230, 1, 60
<b>SEER2 (AHRI 218/248 - 2023)</b>	Cooling Capacity	Btu/h	18,000	23,000	30,000	36,000
	Heating Capacity	Btu/h	18,000	20,600	32,600	36,000
	SEER2	Btu/W	16.8	18.0	16.8	16.8
	EER2	Btu/W	12.0	11.7	11.7	11.0
	HSPF4	Btu/W	9.7	8.5	10.0	9.5
<b>HEATING @ 5 (-15°C)</b>	Rated capacity	Btu/h	18,000	24,000	34,000	37,000
	COP	W/W	1.80	1.80	1.96	1.90
<b>INDOOR UNIT</b>						
<b>AIR FLOW VOLUME</b>	Turbo/Hi/Mi/Lo/Si	CFM	600/564/529/488	823/758/694/629	988/894/805/541	1176/1000/794/617
<b>NOISE LEVEL</b>	Turbo/Hi/Mi/Lo/Si	dB(A)	54/50/46	55/52/46	58/56/47	60/56/53
<b>Net DIMENSION</b>	WxDxH	mm	1098×593×278	1248×593×278	1403×593×278	1578×593×278
	WxDxH	inch	43-1/2×23-3/8×10-7/8	49-1/8×23-3/8×10-7/8	55-1/4×23-3/8×10-7/8	62-1/8×23-3/8×10-7/8
<b>PACKING DIMENSION</b>	WxDxH	mm	1200×680×345	1350×680×345	1505×680×345	1680×680×345
	WxDxH	inch	47-1/4×26-3/4×13-5/8	53-1/8×26-3/4×13-5/8	59-1/4×26-3/4×13-5/8	66-1/8×26-3/4×13-5/8
<b>Net/GROSS WEIGHT</b>		kg	51/56.6	55.6/61.9	61.6/68.2	65.7/71.1
		lbs	112/125	123/136	136/150	145/157

# Pancake Regular Heat\_Specification Up to 16.5 SEER2

MODEL	INDOOR UNIT		MAPHE-H188-2A	MAPHE-H248-2A	MAPHE-H368-2A	MAPHE-H368-2A
	OUTDOOR UNIT		MO1SE-H188-2A	MO1SE-H248-2A	MO1SE-H368-2A	MO1SE-H368-2A
<b>PERFORMANCE</b>						
<b>POWER SUPPLY</b>	IDU	V, Ph, Hz	115/208/230, 1, 60	115/208/230, 1, 60	115/208/230, 1, 60	115/208/230, 1, 60
	ODU	V, Ph, Hz	208/230, 1, 60	208/230, 1, 60	208/230, 1, 60	208/230, 1, 60
<b>SEER2 (AHRI 218/248 - 2023)</b>	Cooling Capacity	Btu/h	18,000	24,000	30,000	36,000
	Heating Capacity	Btu/h	18,000	24,000	30,000	36,000
	SEER2	Btu/W	16.5	18.0	16.4	15.8
	EER2	Btu/W	11.0	11.0	9.6	9.4
	HSPF4	Btu/W	8.6	8.5	7.8	8.1
<b>HEATING @ 5 (-15°C)</b>	Rated capacity	Btu/h	11,000	21,600	19,100	25,500
	COP	W/W	1.80	1.80	1.94	1.92
<b>INDOOR UNIT</b>						
<b>AIR FLOW VOLUME</b>	Turbo/Hi/Mi/Lo/Si	CFM	600/564/529/488	823/758/694/629	988/894/805/541	1176/1000/794/617
<b>NOISE LEVEL</b>	Turbo/Hi/Mi/Lo/Si	dB(A)	54/50/46	55/52/46	58/56/47	60/56/53
<b>Net DIMENSION</b>	WxDxH	mm	1098×593×278	1248×593×278	1403×593×278	1578×593×278
	WxDxH	inch	43-1/2×23-3/8×10-7/8	49-1/8×23-3/8×10-7/8	55-1/4×23-3/8×10-7/8	62-1/8×23-3/8×10-7/8
<b>PACKING DIMENSION</b>	WxDxH	mm	1200×680×345	1350×680×345	1505×680×345	1680×680×345
	WxDxH	inch	47-1/4×26-3/4×13-5/8	53-1/8×26-3/4×13-5/8	59-1/4×26-3/4×13-5/8	66-1/8×26-3/4×13-5/8
<b>Net/GROSS WEIGHT</b>		kg	51/56.6	55.6/61.9	61.6/68.2	65.7/71.1
		lbs	112/125	123/136	136/150	145/157

# Easy to Control Your EVOX Systems

Multiple control methods to maximize your convenience.

Wired Controller  
Built-in WiFi



Remote Control



Mobile Phone



Voice



## MIDEA SMARTHOME APP

Your Evolving System



### Future upgrade

Over-the-air update technology (OTA) for future comfort enhancements



### Check your System's Health

It's like a doctor's appointment for your HVAC

Your Smart Home Comfort Manager

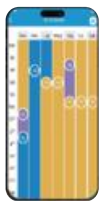

### Set your schedule

Customize the schedule of your unit before start your week



### Set your location

Automatically adjust comfort levels based on your proximity.

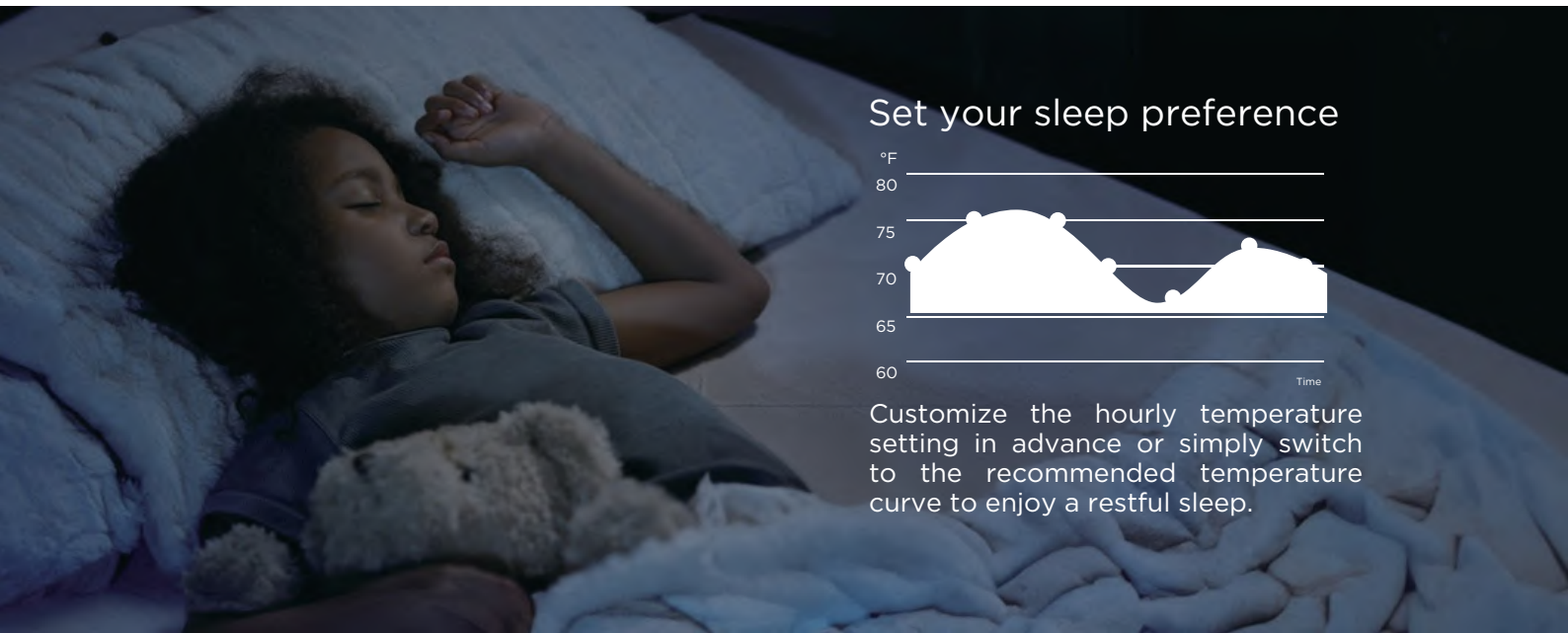

### Set your sleep preference



Customize the hourly temperature setting in advance or simply switch to the recommended temperature curve to enjoy a restful sleep.



## North American HVAC Products Ltd.

---

Add.: 5118 N Fraser Wy, Burnaby, BC V5J 0H1

Tel: 604-430-8496 [info@nahvac.com](mailto:info@nahvac.com) [www.nahvac.com](http://www.nahvac.com)

Midea reserves the right to change the specifications of the product, and to withdraw or replace products without prior notification or public announcement.  
Midea is constantly developing and improving its products.