

R454b Refrigerant

SUBMITTAL DATA SHEET



Series Name: Slim Duct Energy Star Series
Model Number: MDLHU-H12B-2A/MO1E5-H12B-2A

Slim Duct Heat Pump System

Location:	Approval:
Engineer:	Date:
Submitted to:	Construction:
Submitted by:	Unit #:
Reference:	Drawing #:



INDOOR SPEINDOOR SPECIFICATIONCIFICATION

Indoor Air Flow (Turbo/H/M/L/Si) (CFM)	400 / 324 / 265 / 177 / 1178
Indoor Noise Level (Turbo/H/M/L/Si) (dBA)	37 / 37 / 35 / 34 / 26
Indoor static pressure range (in.w.g.)	0-0.4
Dimension (WxDxH)	inch 27-1/2 x 20 x 7-7/8
	mm 700 x 506 x 200
Package (WxDxH)	inch 33-7/8 x 21-1/4 x 11-1/4
	mm 860 x 540 x 285
Net/Gross Weight	lbs 39 / 47
	kg 17.9 / 21.2

OUTDOOR SPECIFICATION

Compressor Type	ROTARY
Compressor Model	KSK103D33UEZ3
Refrigerant	R454B
Refrigerant Oil Charge(mL)	310
Refrigerant Oil	5.65
Outdoor Air Flow (Max) (CFM)	1,236
Outdoor Noise Level (dBA)	55.5
Dimension (WxDxH)	inch 30-1/8 x 11-7/8 x 21-7/8
	mm 765 x 303 x 555
Package (WxDxH)	inch 34-7/8 x 13-1/4 x 24
	mm 887 x 337 x 610
Net/Gross Weight	lbs 63 / 68
	kg 28.2 / 30.7

EFFICIENCY

Cooling		Heating	
SEER2	19.0	HSPF2-4	10.2
EER2	11.7	COP	3.42

PERFORMANCE of Cooling

Cooling (Btu/hr)	
Rated Capacity	11,500
Min/Max Capacity	3,100~13,000
Moisture Removal(L/h)	0.99
Standard Operating Range(°F/°C)	-13~122 (-25 ~ 50)
Conditions:	Indoor: 80°F DB/67°F WB Outdoor: 95°F DB/75°F WB

PERFORMANCE of Heating

Heating (Btu/hr)	
1. @ 47°F Rated	12,000
1. @ 47°F Min/Max Capacity	3,700~15,600
2. @ 17°F Rated	9,500
3. @ 5°F Rated: Capacity / COP	8,800/2.25
3. @ 5°F Max: Capacity	8,800
Standard Operating Range(°F/°C)	-13~75 (-25 ~ 24)
1. Conditions:	Indoor: 70°F DB/60°F WB Outdoor: 47°F DB/43°F WB
2. Conditions:	Indoor: 70°F DB/60°F WB Outdoor: 17°F DB/15°F WB
3. Conditions	Indoor: 70°F DB/60°F WB Outdoor: 5°F DB/5°F WB

ELECTRICAL

Power Supply	208/230V,60Hz,1Ph
System MCA	12.0
Connection Wiring	AWG 14/4
System MOCP	15.0
Compressor RLA	7.3
Outdoor Fan Motor RLA	0.6
Outdoor Fan Motor W	34
Indoor Fan Motor RLA	1.2
Indoor Fan Motor W	81
System Power Input @ Cooling (W)	983 (150 ~ 1,210)
System Power Input @ Heating (W)	1,028 (255 ~ 1,310)
MCA: Min. circuit amps (A)	MOCP: Max. over current protection (A)
RLA: Rated load amps (A)	W: Fan motor rated output (W)

PIPING

Throttle type(Indoor)	N/A
Throttle type(Outdoor)	EXV
Liquid Size	1/4" (6.35mm)
Gas Size	1/2" (12.7mm)
Max. Piping Length(ft/m)	82 (25)
Max. Height Difference(ft/m)	49 (15)
Max. Pre-charged Length(ft/m)	25 (7.5)
Refrigerant Pre-charged Amount(oz/kg)	32 (0.92)
Additional Charge of Refrigerant((oz/ft)/(g/m)	0.16 (15)
Connection Method	Flared

Indoor Unit Dimension

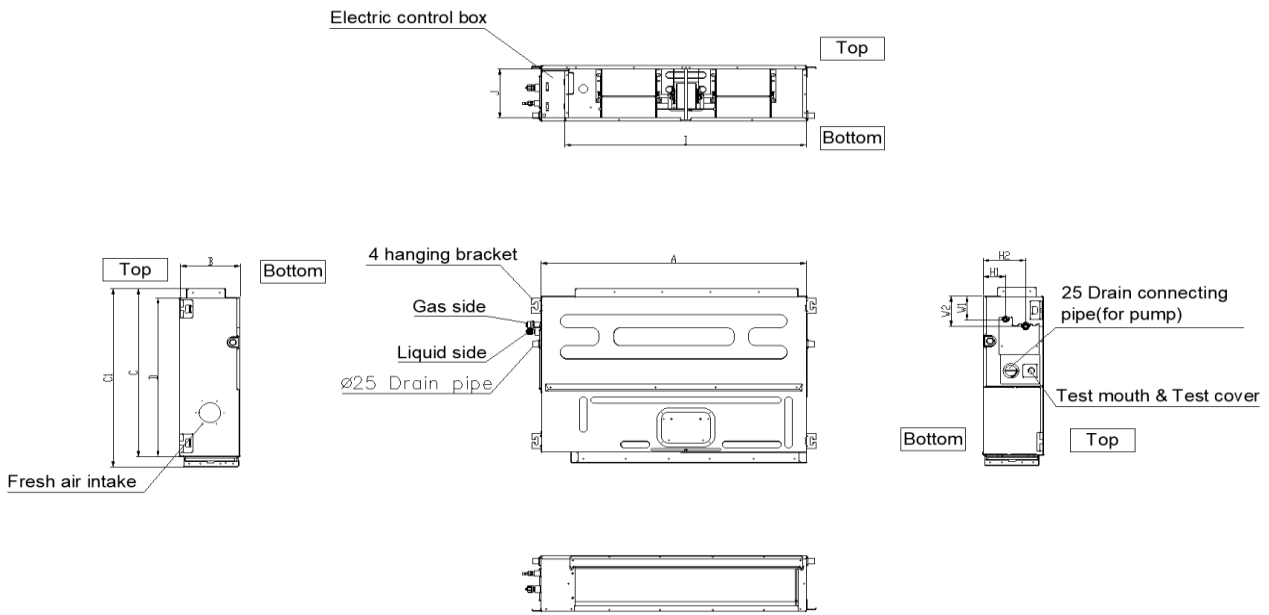

Model(kBtu/h)	unit	A	B	C	C1	D
	6 -12	mm	700	200	470	506
in		27-1/2	7-7/8	18-1/2	20	17-3/4
18	mm	880	210	634	674	600
	in	34-5/8	8-1/4	25	26-1/2	23-5/8

Installation Instruction

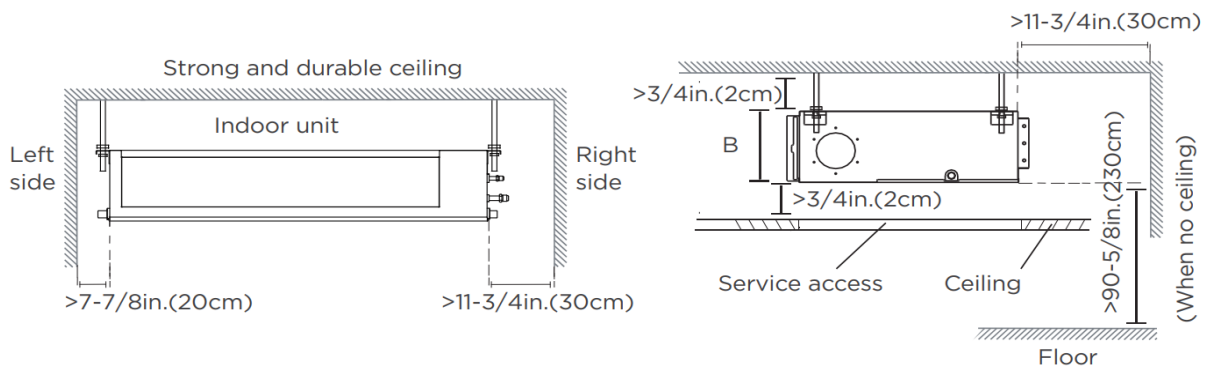

Outdoor Unit Dimension

Unit: inch (mm)

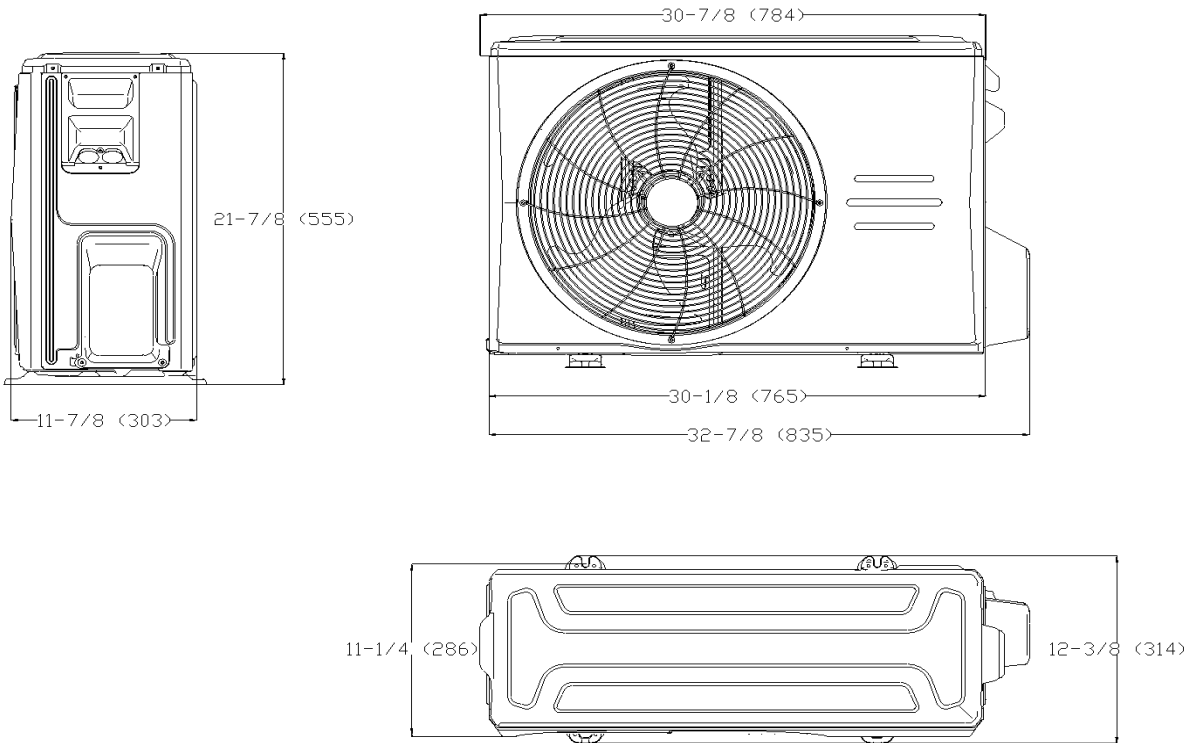

Installation Instruction

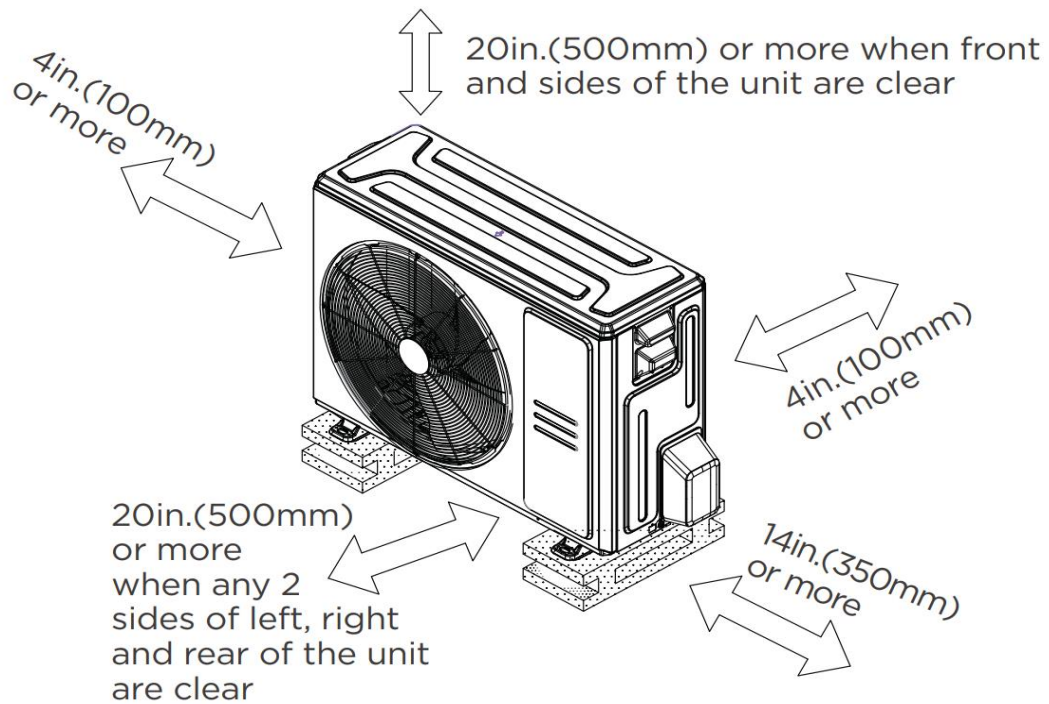

Fan performance

The default setting is SP1, which can be changed to SP2,3,4, using the wired controller.

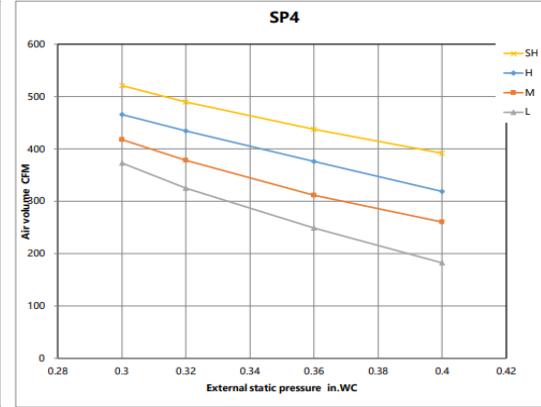
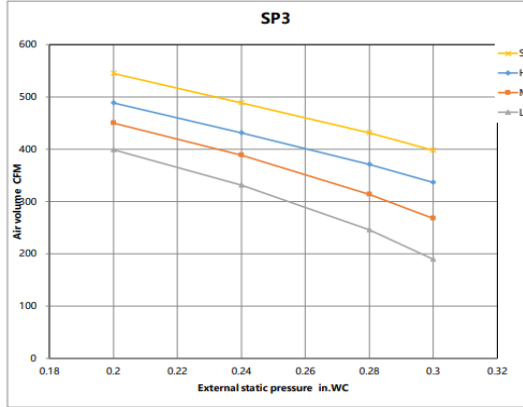
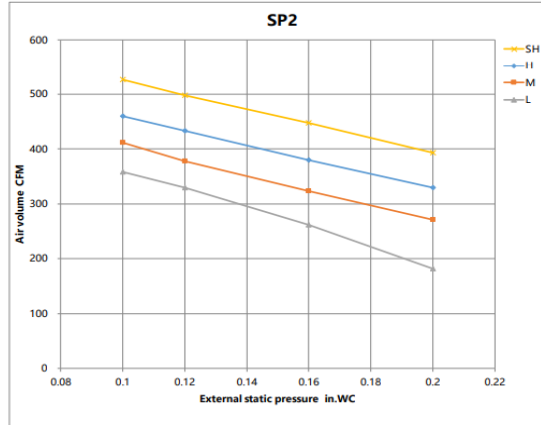
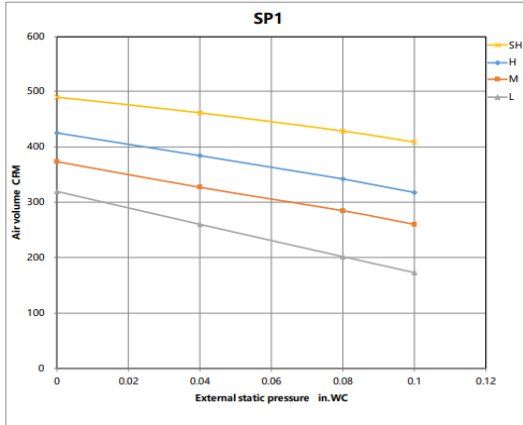

Constant airflow

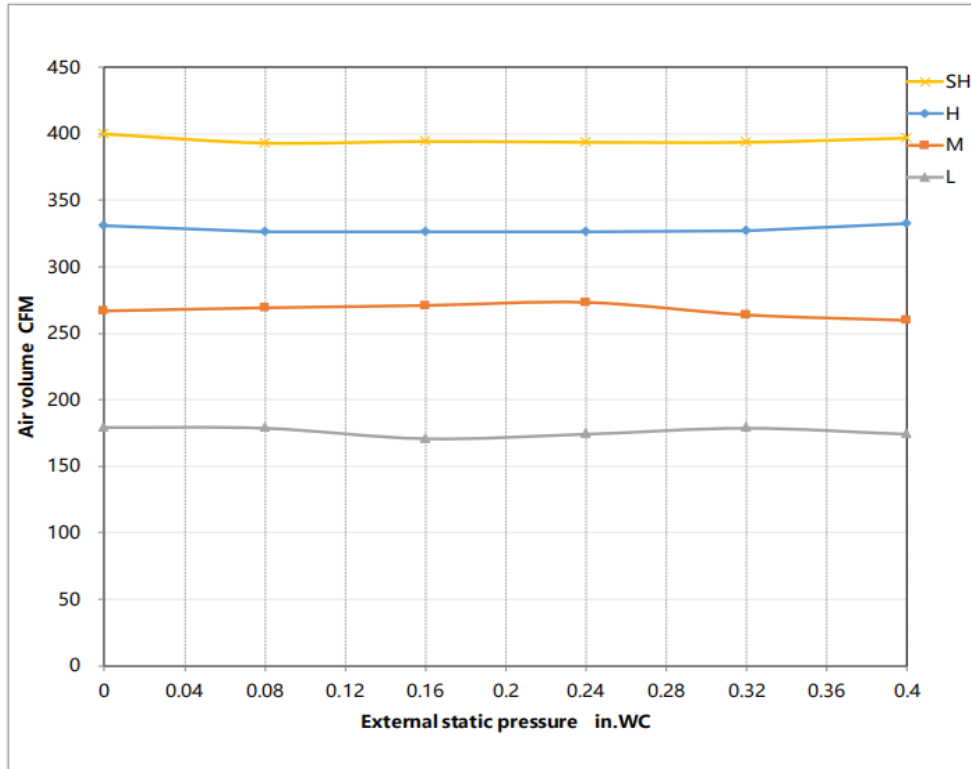

FEATURES

- Compatible with both horizontal and vertical installation(Optional)
- Static pressure setting stages: 4
- Refrigerant leakage detection sensor
- Constant airflow
- Built-in pump
- i-clean
- Fan speed stages: 1~100%
- WiFi capability: through WiFi dongle or wired controller with built-in WiFi
- OTA(by using wired controller 120N(X6W))
- 2-pin connector(HA/HB) for programmable wired controller
- Multiple control options available:
 - Two way communication wired controller:120N(X6)
 - Two way communication wired controller with built-in WiFi:120N(X6W)
 - Infrared wired controller: 120L
 - Wireless remote controller
 - Third-Party 24V Thermostat*

*24V interface is required.

North American HVAC Products Ltd.

Add.: #100 5118 N Fraser Wy, Burnaby, BC V5J 0H1

Tel: 604-430-8496 info@nahvac.com www.nahvac.com

Midea reserves the right to change the specifications of the product, and to withdraw or replace products without prior notification or public announcement.
Midea is constantly developing and improving its products.